

QST

April, 1937
25 cents

devoted entirely to

amateur radio

In this Issue—

**New Dope on
Crystal
Oscillators**

**In Full—The
Ohio Flood**

**Inverse
Feed-Back in
Phone Work**

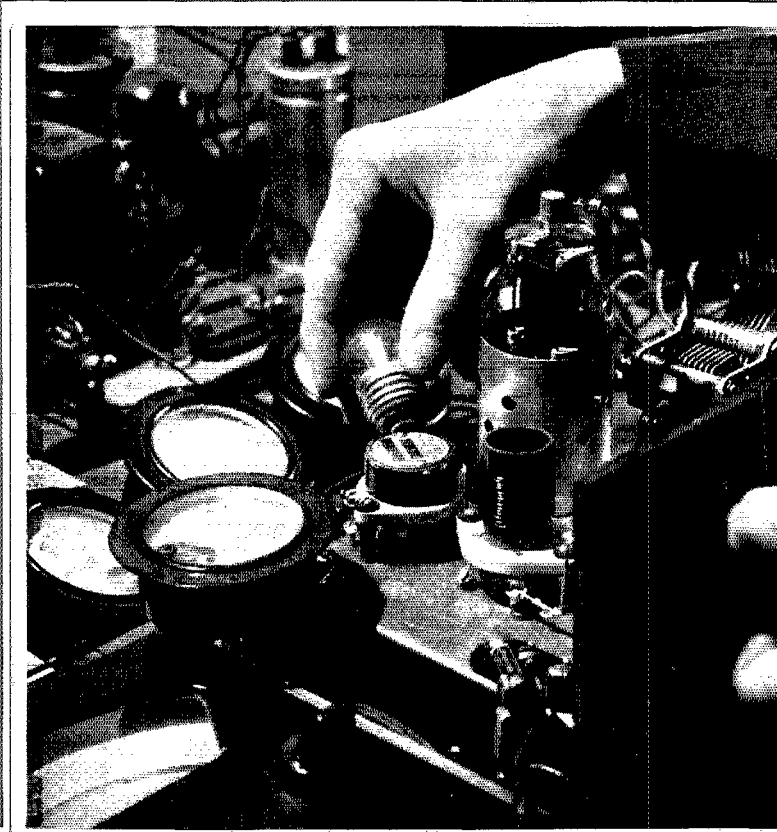

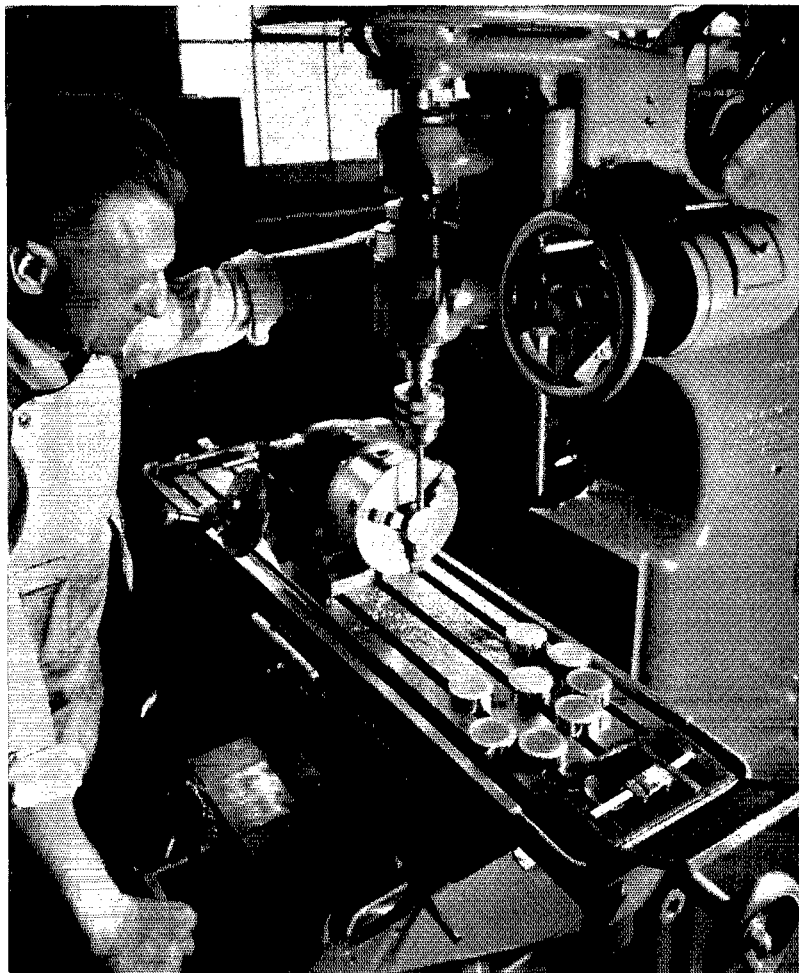

A crystal holder is a simple thing but this one is being very carefully made. Completed, it will consist of 54 parts, machined and ground with precision. It will hold the quartz "heart" of a Collins transmitter which will beat millions of times per second. Final accuracy will be within five parts in a million.

In every department of the 40,000 square feet of Collins' plant similar highly specialized technical jobs are being done. Unique, ingenious, painstaking, this work is responsible for the wide acceptance of Collins equipment.

Collins Radio Company, Cedar Rapids, Iowa

Your Guarantee!

of

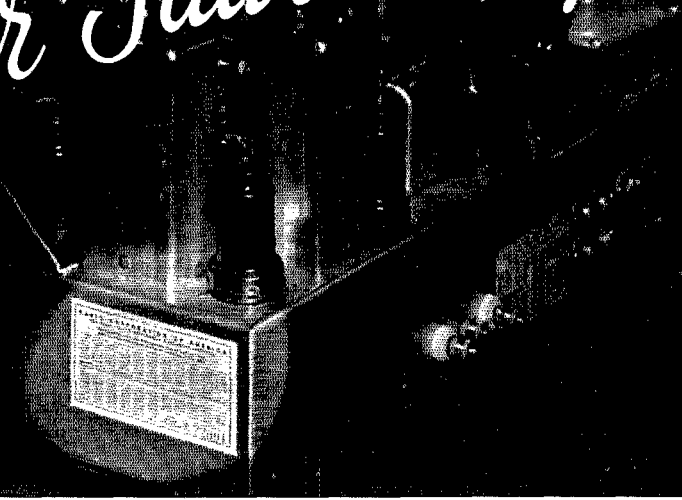

ADVANCED ENGINEERING

NO ORGANIZATION today can hope to maintain an engineering staff that, in itself, can lead in all the modern radio developments. The Hallicrafters' engineers are as competent and capable as any, but even they do not rely entirely upon their own resources. The finest brains of radio science have contributed to the design of Hallicrafters receivers as the list of over 200 patents under which Hallicrafters receivers are licensed will testify.

Look for the license tags on the chassis of any receiver you purchase, they are your guarantee of advanced design, of modern engineering.

JUST A FEW OF THE MANY PATENTS UNDER WHICH HALLICRAFTERS RECEIVERS ARE BUILT

1,944,746	1,869,331	1,558,437	1,508,151	1,710,035
1,948,308	1,924,485	1,573,374	1,734,038	1,751,854
1,949,843	1,942,327	1,631,646	1,447,773	2,000,113
1,958,062	1,403,932	1,702,833	1,869,323	2,001,277
1,959,197	1,459,412	1,868,443	1,639,713	2,016,760
1,976,249	1,465,332	1,342,885	1,382,738	2,024,017
1,969,903	1,537,708	1,507,016	1,405,523	2,036,319
	2,038,294	2,042,571		2,045,910

the hallicrafters inc.

2611 Indiana Ave., Chicago, Ill.

Cable Address: "HALLICRAFT" Chicago

AMERICA'S LEADING MANUFACTURER OF COMMUNICATIONS RECEIVERS

Say You Saw It in QST — It Identifies You and Helps QST

THE SUPER SKY RIDER

THE SKY RIDER
THE ULTRA SKY RIDER
THE SKY CHIEF
THE SKY BUDDY

THE SKY RIDER
COMMERCIAL
THE SKY CHALLENGER



"100%" SAY AMATEURS *who have operated the* **NEW SKY CHALLENGER**

AMATEUR RADIO'S GREATEST VALUE

Look at these Unusual **FEATURES:**

- 9 Tubes, 6 Metal — 3 Glass
- 38 mc. to 535 kc. (7.9 to 540 meters)
- 5 Band 338° Main Tuning Dial
- Electrical Band Spread
- Iron Core I. F. Transformers for Improved Selectivity
- Direct Calibration Tuning — No Charts or Tables
- Automatic Volume Control
- Single Signal Crystal Control
- Beat Frequency Oscillator
- New Low Price
- Time Payment Plan

The new SKY CHALLENGER is truly sensational in value! The radio amateur can now obtain a really fine communications receiver with the necessary features and controls at this sensationally low price.

\$69.50

Bettering many higher priced receivers in sensitivity and selectivity, tuning from 38 mc. to 535 kc. (7.9 to 540 meters) without skips, on 5 bands, we believe the SKY CHALLENGER is today's outstanding value in amateur radio.

Stop in to see it today, or write for complete description.

NOW AVAILABLE ON NEW HALLICRAFTERS TIME PAYMENT PLAN

FRECK RADIO & SUPPLY CO.

"The House of a Million Radio Parts"

Distributors of All Radio Apparatus

38 BILTMORE AVENUE

ASHEVILLE, N. C.

the hallicrafters inc.

QST

devoted entirely to

AMATEUR RADIO

PUBLISHED, MONTHLY, AS ITS OFFICIAL ORGAN, BY THE AMERICAN RADIO RELAY LEAGUE, INC., AT WEST HARTFORD, CONN., U. S. A.; OFFICIAL ORGAN OF THE INTERNATIONAL AMATEUR RADIO UNION

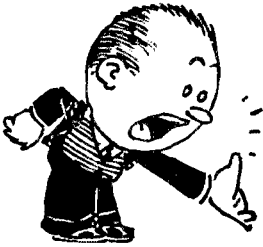

APRIL

1937

Volume XXI

Number 4



Kenneth B. Warner (Secretary, A.R.R.L.), *Editor-in-Chief and Business Manager*; Ross A. Hull, *Associate Editor*; James J. Lamb, *Technical Editor*; George Grammer, *Assistant Technical Editor*; Clark C. Rodimon, *Managing Editor*; David H. Houghton, *Circulation Manager*; F. Cheyney Beekler, *Advertising Manager*; Charles Brunelle, *Assistant Advertising Manager*.

Editorial and Advertising Offices

38 La Salle Road
West Hartford, Connecticut

Subscription rate in United States and Possessions and Canada, \$2.50 per year, postpaid; all other countries, \$3.00 per year, postpaid. Single copies, 25 cents. Foreign remittances should be by international postal or express money order or bank draft negotiable in the U. S. and for an equivalent amount in U. S. funds.

Entered as second-class matter May 29, 1919, at the post office at Hartford, Connecticut, under the Act of March 3, 1879. Acceptance for mailing at special rate of postage provided for in section 1103, Act of October 3, 1917, authorized September 9, 1922. Additional entry at Concord, N. H., authorized February 21, 1929, under the Act of February 28, 1925.

Additional second-class entries to cover sectional editions authorized March 20, 1935. Copyright 1937 by the American Radio Relay League, Inc. Title registered at United States Patent Office.

The Contents

Editorials	9
The Maxim Memorial Relay	10
"In the Public Interest, Convenience and Necessity" <i>Clinton B. DeSoto</i>	11
Directed Vertical Radiation with Diamond Antennas <i>Morton E. Moore, W6AUX and F. L. Johnson, W6CNX</i>	21
Canada-U. S. A. Contact Contest	25
What the League Is Doing	26
Dixie Jones' Owl Juice	27
Kansas State Convention	27
Iowa State Convention	27
A New I. F. Coupling System for Superhet Receivers <i>James J. Lamb</i>	28
George L. Bidwell	30
South Carolina Convention	30
A Practical Survey of Pentode and Beam Tube Crystal Oscillators for Fundamental and Second Harmonic Operation <i>James J. Lamb</i>	31
A Push-Pull Amplifier for the Band-Switching Exciter <i>George Grammer</i>	39
How Would You Do It?	43
Inverse Feedback Applied to the Speech Amplifier for the Amateur 'Phone Transmitter <i>J. B. Carter</i>	46
Oregon State Convention	51
Should You Choose Radio Engineering as a Career? <i>Frederic D. Merrill, Jr.</i>	52
I.A.R.U. News	54
I.R.E.-U.R.S.I. Meeting	55
New Receiving Tubes	55
Operating News	56
Correspondence Department	65
Standard Frequency Transmissions	102
Silent Keys	110
Ham-Ads	123
QST's Index of Advertisers	126

Now



TEN METERS WITH NEW SUPER-PRO!



- TWO STEPS OF RF!
- REAL SENSITIVITY!
- REAL IMAGE REJECTION!

HAMMARLUND now announces a special "Super-Pro" receiver to cover from 1.25 to 40 megacycles — that affords new outstanding results!

The new 20 to 40 mc. range in this latest model is the result of painstaking research and engineering, and is not just a casual makeshift! Two steps of R.F. amplification are used in this range as well as in the remaining four ranges from 20 down to 1.25 mc. This provides an image rejection ratio of 150 to 1, and a sensitivity of 0.8 micro-volt (30% modulated) with a signal-to-noise ratio of 6 to 1 at 28 mc.!

The 2000 kilocycle span on the 28 to 30 mc. band is covered by 90 degrees of the band spread dial. Tuning is so arranged that all amateur bands fall in the center of the scale as the band switch is turned.

All the other popular features that contribute to the success of the standard 15 to 560 meter "Super-Pro" also have been retained in this model, viz. — direct tuning, accurately calibrated 3 to 16 kc. band-

width panel control, graduated audio and sensitivity controls, calibrated beat-oscillator control, 8 metal and 8 glass tubes, stand-by switch, AVC-manual switch, C.W.-mod. switch, phone-speaker switch, rugged self-contained tuning unit with trouble-free cam operated knife switch, variable crystal filter, etc.

Complete details on this model and the standard model appear in a special booklet. Mail coupon below for your copy!

MAIL THIS COUPON!

HAMMARLUND MFG. CO., INC. Q-4
 424-438 W. 33d St., New York
 Please send me new "Super-Pro" booklet.
 Please send me new "37" catalog.

Name.....
 Address.....
 City..... State.....



Section Communications Managers of the A.R.R.L. Communications Department

All appointments in the League's field organization are made by the proper S.C.M., elected by members in each Section listed. Mail your S.C.M. (on the 10th of each month) a postal covering your radio activities for the previous 30 days. Tell him your DX, plans for experimenting, results in phone and traffic. He is interested, whether you are an A.R.R.L. member or get your QST at the newsstands; he wants a report from every active ham. If interested and qualified for O.R.S., O.P.S. or other appointments he can tell you about them, too.

Eastern Pennsylvania	W3EZ	ATLANTIC DIVISION	James M. Bruning	339 W. Lancaster Ave.	Haverford
Maryland-Delaware-District of Columbia	W3BAK		Edgar L. Hudson		Laurel, Delaware
Southern New Jersey	W3ZX		Carroll D. Kentner	1107 Park Ave.	Collingswood
Western New York	W3DSS		Charles Smith	310 E. Walnut St.	Oneida
Western Pennsylvania	W8OFO		Kendall Speer, Jr.		Lowber
		CENTRAL DIVISION			
Illinois	W9KJY		L. John Huntoon	327 Brandon Ave.	Glen Ellyn
Indiana	W9TE		Arthur L. Braun	530 East Morris St.	Indianapolis
Kentucky	W9AUH		G. W. Mossbarger	Box 177	Camp Taylor
Michigan	W8DPE		Harold C. Bird	R.F.D. 2	Pontiac
Ohio	W8AQ		E. H. Gibbs	300 High St.	Wadsworth
Wisconsin	W9ATO		E. A. Cary	3922 No. 19th Pl.	Milwaukee
		DAKOTA DIVISION			
North Dakota	W9OEL		Hartwell B. Burner		Hope
South Dakota	W9SEB		Andrew J. Kjar	221 West Prospect Ave.	Pierre
Northern Minnesota	W9OWU		Leonard Hofstad		Elbow Lake
Southern Minnesota	W9DCM		Webster F. Soules	3549 36th Ave., So.	Minneapolis
		DELTA DIVISION			
Arkansas	WSABI		H. E. Velte	4415 West 12th St.	Little Rock
Louisiana	WSDKR		Eugene H. Treadaway	2749 Myrtle St.	New Orleans
Mississippi	W5CWO		J. H. Weems, Jr.	P. O. Box 244	State College
Tennessee	W4DEP		B. G. Lowrey Smith	673 Hillcrest St.	Memphis
		HUDSON DIVISION			
Eastern New York	W2ZLU		Robert E. Haight	511 South Holmes St.	Scotia
N. Y. C. & Long Island	W2AZV		E. L. Baunach	102 Central Ave.	Massapequa, L. I.
Northern New Jersey	W2GMN		Fred C. Read	1014 North Ave.	Elizabeth
		MIDWEST DIVISION			
Iowa	W9NNM		Owen Williams	108 No. Johnson St.	Iowa City
Kansas	W9PB		Harry E. Legler	304 Miami St.	Hawatha
Missouri	W9CJR		J. Dewey Mills	Box 205	Mount Vernon
Nebraska	W9FAM		Samuel C. Wallace	Green St.	Clarks
		NEW ENGLAND DIVISION			
Connecticut	W1CTI		Frederick Ellis, Jr.	19 Merrill Rd.	Norwalk
Maine	W1CDX		John W. Singleton	Peaks Island	Portland
Eastern Massachusetts	W1ABG		Albert N. Giddis	128 Crawford St.	Lowell
Western Massachusetts	W1IAH		William J. Barrett	239 Columbia St.	Adams
New Hampshire	W1BFT		Carl E. Evans	80 No. State St.	Concord
Rhode Island	W1HRC		Clayton C. Gordon	192 Washington Ave.	Providence
Vermont	W1GNF		Alvin H. Battison	1 Central St.	Windsor
		NORTHWESTERN DIVISION			
Alaska	K7PQ		Richard J. Fox	Box 301	Ketchikan
Idaho	W7NH		Nellie H. Hart	Box 6	Twin Falls
Montana	W7CRH		Russell U. Richmond		Somers
Oregon	W7AIV		Eugene E. Lovejoy	5013 N. E. Clackamas	Portland
Washington	W7WY		Robert H. Votaw	Route 1, Box 398	Vancouver
		PACIFIC DIVISION			
Hawaii	K6AJA		Otis Hill	Box 952	Hilo
Nevada	W6BIC		Edward W. Heim	509 Claremont St.	Reno
Santa Clara Valley	W6FBW		Elbert Amarantes	475 So. 11th St.	San Jose
East Bay	W6JTV		Harold J. Burchfield	2340 106th Ave.	Oakland
San Francisco	W6BFT		Alex D. Whitaker, Jr.	79 Elmer Ave.	Mill Valley
Sacramento Valley	W6DVE		Geo. L. Woodington	716 Redwood Ave.	North Sacramento
Philippines	KA1GR		George L. Rickard	Box 849	Manila
San Joaquin Valley	W6LPE		Angelo V. Astone	729 Safford	Fresno
		ROANOKE DIVISION			
North Carolina	W4OG		H. S. Carter	P. O. Box 111	Winston-Salem
Virginia	W3UVA		Charles M. Waff, Jr.	P. O. Box 1212	Univ., Charlottesville
West Virginia	W8KKG		Dr. Wm. H. Kihedaffer		Lost Creek
		ROCKY MOUNTAIN DIVISION			
Colorado	W9FA		Glen Glasscock	2164 So. Corona St.	Denver
Utah-Wyoming	W7COH		Townsend J. Rigby		Midwest, Wyoming
		SOUTHEASTERN DIVISION			
Alabama	W4DGS		James F. Thompson	2248 S. Arlington Ave.	Birmingham
Eastern Florida	W4ASR		William C. Shelton	556 Westmoreland Drive	Daytona Beach
				"Hillcrest", P. O. Box 652	
Western Florida	W4MS		Edward J. Collins	1517 East Brainard St.	Pensacola
Georgia-So. Carolina-Cuba-Isle-of-Pinea-Porto Rico-Virgin Islands	*W4PM		Charles W. Davis	2136 NE Boulevard Dr.	Atlanta, Ga.
		SOUTHWESTERN DIVISION			
Los Angeles	W6GXM		Don M. Draper	4421 West 63 St.	Los Angeles
Arizona	W6LVG		C. C. Day	"La Posta Quemada"	Vail
San Diego	W6EOP		Harry A. Ambler	4101 Hamilton St.	San Diego
		WEST GULF DIVISION			
Northern Texas	W5BII		Richard M. Cobb	Box 185	Dodd City
Oklahoma	W5CEZ		Carter L. Simpson	2010 So. 4th St.	Ponca City
Southern Texas	W5BDI		Ammon O. Young	4803 Eli St.	Houston
New Mexico	W5CGJ		Joseph M. Eldodt		Chamita
		MARITIME DIVISION			
Maritime	VE1DQ		A. M. Crowell	69 Dublin St.	Halifax, N. S.
		ONTARIO DIVISION			
Ontario	VE3SG		Fred H. B. Saxon	302 Lee Ave.	Toronto, Ont.
		QUEBEC DIVISION			
Quebec	VE2EE		Stan Comach	780 Brault Ave.	Verdun, P. Q.
		VANALTA DIVISION			
Alberta	VE4LX		Alfred D. Kettenbach		Rockyford
British Columbia	VE5EP		D. R. Vaughan-Smith	1221 Burnaby St.	Vancouver
		PRAIRIE DIVISION			
Manitoba	VE4BG		A. J. R. Simpson	635 Garfield St.	Winnipeg
Saskatchewan	VE4EL		Wilfred Skaife	2040 McTavish St.	Regina

* Officials appointed to act until the membership of the Section choose permanent S.C.M.'s by nomination and election.

New **AMATEUR CLASS "B" TUBE**
(Low distortion, Zero Bias Amplifier)

has
**SPEER
GRAPHITE
ANODE**

This coupled with the manufacturer's features of design, make it the equal of larger, costlier tubes with other anodes.

Manufacturers of tubes with Graphite Anodes know that this important element lengthens the life, improves the performance and insures the uniformity of their product. Use tubes with Speer Graphite Anodes for better service and satisfaction.

List of tubes with Speer Graphite Anodes and booklet on request. Write!



SPEER CARBON COMPANY
ST. MARYS, PA.

More Distance Per Watt

WITH

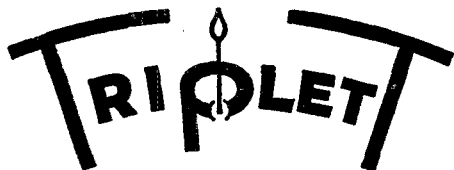

**MODULATION
MONITOR**

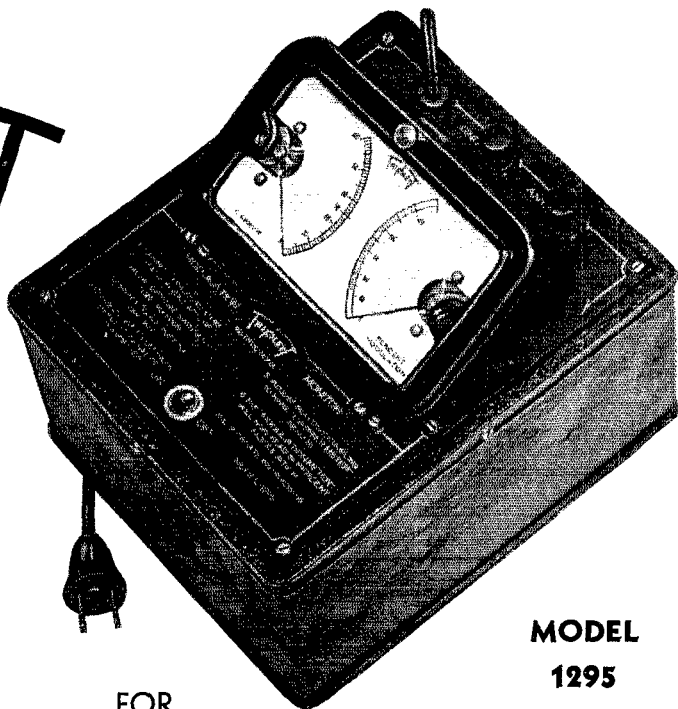

DEALER PRICE **\$24.⁸³**
PRICE

**MODEL
1295**

FOR

All Voice Transmitting Stations

Model 1295 Modulation Monitor enables you to tune your transmitter to maximum efficiency thereby saving the power loss of undermodulation. Result — clearer signal to distant stations.

Shows actual modulation percentage on direct reading scale.

Eliminates the uncertainty of depending on the ear, variation of antenna ammeter or the loop and light in determining carrier shift and percentage of modulation. Actual modulation percentage is shown on direct reading Triplett Twin Precision Instrument.

Scale indicates modulation from 40 to 120 per cent. All readings in peaks. Visual information on second dial provided for carrier reference level for the modulation

test and also to check carrier shift during modulation. All uncertainties regarding final adjustments on the transmitter eliminated with the use of Triplett's Modulation Monitor. Prevents monkey chatter, cross talk and B.C.L. interference. Factory calibrated and no further calibration needed.

Model 1295 Modulation Monitor, complete with necessary accessories. Dealer Price **\$24.83**

THIS IS A TRIPLETT MASTER UNIT

See the Modulation Monitor at your jobbers. Triplett manufactures a complete line of Precision Radio Testing Equipment and Precision Electrical Measuring Instruments for the Amateur and Experimenter. Complete information available on request.

SEE YOUR JOBBER — WRITE FOR CATALOG

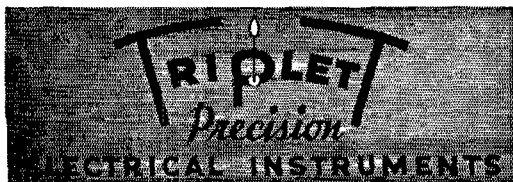

THE TRIPLETT ELECTRICAL INSTRUMENT CO.
254 Harmon Ave., Bluffton, Ohio

Without obligation please send me more information on

Model 1295 Modulation Monitor

I am also interested in

Name

Address

City State

The American Radio Relay League



THE AMERICAN RADIO RELAY LEAGUE, INC., is a non-commercial association of radio amateurs, bonded for the promotion of interest in amateur radio communication and experimentation, for the relaying of messages by radio, for the advancement of the radio art and of the public welfare, for the representation of the radio amateur in legislative matters, and for the maintenance of fraternalism and a high standard of conduct.

It is an incorporated association without capital stock, chartered under the laws of Connecticut. Its affairs are governed by a Board of Directors, elected every two years by the general membership. The officers are elected or appointed by the Directors. The League is non-commercial and no one commercially engaged in the manufacture, sale or rental of radio apparatus is eligible to membership on its board.

"Of, by and for the amateur," it numbers within its ranks practically every worth-while amateur in the nation and has a history of glorious achievement as the standard-bearer in amateur affairs.

Inquiries regarding membership are solicited. A bona fide interest in amateur radio is the only essential qualification; ownership of a transmitting station and knowledge of the code are not prerequisite. Correspondence should be addressed to the Secretary.

HIRAM PERCY MAXIM, FOUNDER

OFFICERS

- President*.....EUGENE C. WOODRUFF, W8CMP
State College, Pa.
- Vice-President*.....GEORGE W. BAILEY, W1KH
Weston, Mass.
- Secretary*.....KENNETH B. WARNER, W1EH
West Hartford, Connecticut
- Treasurer*.....ARTHUR A. HEBERT, W1ES
West Hartford, Connecticut
- Communications Mgr.*...F. EDWARD HANDY, W1BDI
West Hartford, Connecticut
- ◆
- General Counsel*.....PAUL M. SEGAL
1010 Shoreham Building, Washington, D. C.
- ◆

Address all general correspondence to the administrative headquarters at West Hartford, Connecticut

DIRECTORS

- President*
EUGENE C. WOODRUFF.....W8CMP
234 W. Fairmount Ave., State College, Pa.
- Vice-President*
GEORGE W. BAILEY.....W1KH
74 Webster Road, Weston, Mass.
- Canadian General Manager*
ALEX REID.....VE2BE
169 Logan Ave., St. Lambert, P. Q.
- Atlantic Division*
WALTER BRADLEY MARTIN.....W3QV
Box 612, Roslyn, Pa.
- Central Division*
R. H. G. MATHEWS.....W9ZN
100 East Ohio St., Chicago
- Dakota Division*
CARL L. JABS.....W9BVH
1822 James St., St. Paul, Minn.
- Delta Division*
E. RAY ARLEDGE.....W5SI
P. O. Box 286, Pine Bluff, Ark.
- Hudson Division*
KENNETH T. HILL.....W2AHC
115 Willow St., Douglaston, L. I., N. Y.
- Midwest Division*
FLOYD E. NORWINE, JR.....W9EFC
120 South Fourth St., St. Louis, Mo.
- New England Division*
PERCY C. NOBLE.....W1BVR
37 Broad St., Westfield, Mass.
- Northwestern Division*
RALPH J. GIBBONS.....W7KV
c/o United Air Lines, Peniletton, Ore.
- Pacific Division*
S. G. CULVER.....W6AN
2962 Russell St., Berkeley, Calif.
- Roanoke Division*
H. L. CAVENESS.....W4DW
State College Station, Raleigh, N. C.
- Rocky Mountain Division*
EDWARD C. STOCKMAN.....W9ESA
618 So. Williams St., Denver
- Southeastern Division*
BENNETT R. ADAMS, JR.....W4APU
1512 Grove Place, Homewood, Ala.
- Southwestern Division*
CHARLES E. BLALACK.....W6GG
443 Main St., El Centro, Calif.
- West Gulf Division*
WAYLAND M. GROVES.....WSNW
c/o Humble Pipe Line, Talco, Texas

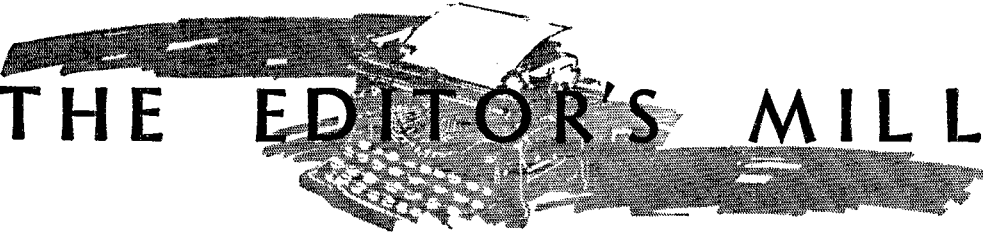

THE EDITOR'S MILL

AS ONE result of the great floods early this year, the Federal Communications Commission has sent two investigators into the area to study emergency communication requirements and is now to receive a report from them which, rumor says, will recommend a complete national disaster communication system involving both wire and radio. What aids or what dangers such a program may offer to amateur radio it is too early to say, but in any event the subject is important.

We hope that all concerned will bear in mind that amateur radio's important contributions to emergency communication are not susceptible to regimentation. In the first place, the very participation of an amateur is voluntary. In the second place, our unique ability to serve derives primarily from our vast numbers, the fact that there will always be some of us in position to help. An emergency is, by nature, an unpredictable thing, and it will never be devoid of confusion. Improvements can be made, of course, and we believe in broad-gauge advance planning, but any attempt to detail specifications of what stations will handle what classes of traffic for whom is doomed to failure and would choke off our performance ability in a tangle of red tape. Better confusion and duplication than that precious relief be endangered by paper rules.

The amateur's aid in the recent emergency was a mighty one. We are proud of our fellows. We find pride, too, in the weight of this demonstration of the wisdom of the national policy of encouraging amateur radio. We do not propose to lose those advantages by having amateur radio subordinated to any other agency in time of emergency. We can do the job better alone and that is how we want to do it. The very greatness of our performance early this year now attracts many agencies who would like to commandeer, direct, have assigned, and so on. Let them understand that this service comes *from* us, of our own volition as free agents. We shall want to help them all as much as we can, but of our own accord, not by direction. There are important improvements that need to be made in our planning and coordinating but they are interior problems of ama-

teur radio, and the job is to be done only by us amateurs within our own structure.

COMES April and the realization that the A.R.R.L. Board of Directors will soon be meeting. All members with new ideas or suggestions for the solution of current problems or for the betterment of amateur radio should communicate with their division directors. The addresses are in the directory in each issue of *QST*. A.R.R.L. decisions are made by divisions and each director wishes to know how his "gang" feels about the questions of the day.

ALTHOUGH *QST* is now a landmark in amateur radio, it still depends upon advertising support to pay the printer. It is doing a swell job for its advertisers but it is just as important for our members nowadays to mention *QST* in writing advertisers as it was in the old days. There is, we suppose, a temptation not to do this these days, simply because *QST* is now an institution, sort of like the telephone company, which nobody ever bothers to credit. Membership cooperation—mutual support—has built this great journal of the American shack. Let's keep it up, fellows: "Say you saw it in *QST*—it identifies you and helps *QST*."

THERE is not so great an occupancy of the upper half of the 28- to 30-Mc. band as we would like to see. Other people may be making bedroom eyes at those frequencies. Moreover, interference, particularly at week-end, is getting pretty tough. Obviously we ought to spread out. The 'phone stations can't spread out, being assigned only half the band, so the move ought to come on the part of the c.w. stations. We suppose the heavy population in the low-frequency half derives from the use of crystals primarily used in lower bands. That's a small consideration in comparison with the advantages of a clear frequency. What do you say, you 10-meter c.w. fellows—how's to spread out a bit, get out from under the 'phone carriers, and give that upper-frequency half some needed population?

E. B. W.

The Maxim Memorial Relay

THIS event, held on February 17th, on the first anniversary of the passing of our founder, Hiram Percy Maxim, was most successful. It parallels in its magnitude of success the A.R.R.L. 20th Anniversary Relay held three years ago. The League's Official Broadcasting Stations and Official Phone Stations each transmitted President Woodruff's commemorative message each hour, between 7 and 11 p.m. local time, on the evening of the 17th, the stations covering the entire country. At this writing radiograms are still coming in, and many hundred acknowledgments of reception have been received. A commemorative card signed by our A.R.R.L. president is being mailed to each individual who took part in the relay, in appreciation of the amateur spirit shown on this occasion.

The Connecticut station line-up for receiving relayed messages functioned admirably. Outside of the Headquarters station, the Connecticut operators receiving most messages were W1HSX (c.w.); W1SZ (3.9- and 14-Mc. 'phone); W1HSX (c.w.) and W1IMV (1.7 Mc.). At W1AW a 30-hour watch was kept, Chief Operator Hal Bubb taking the bulk of the operating, shifts being taken by Don, and FH. Members sending and relaying express themselves as enthusiastic for having the relay made an annual event. In the future we might make the commemoration an "opening season" activity, starting on the 1938 date (September) nearest that of the birthday of our founder. Connecticut stations were ready for even a greater volume of traffic than developed, and the Nutmeg gang covered every band thoroughly for the whole period of the relay. Three score stations on the delivery end received the special acknowledging messages sent to A.R.R.L. The League is grateful to the valuable assistance rendered by all Connecticut operators in this relay. The deliveries, except for 50 miscellaneous mailed messages, were made by these stations as follows:

CONNECTICUT STATION REPORTS

3.5-7-14-Mc. telegraph: W1AW * 106; W1HSX 36; W1BDI 31; W1IKE 29; W1AGR 27; W1GME 17; W1JPE 13; W1ES 12; W1KY 11; W1FE W1TI W1JMY 10; W1GVV W1YB W1TD 9; W1CSC W1JXP 8; W1GKM W1JUD 6; W1BIB W1FAJ W1UE 5; W1BHM W1GC W1HPI W1BT W1JHN W1JXV W1KAY W1TS 4; W1CEJ W1FY W1GYT W1GR 3; W1BNB W1DMP W1NPN W1JL W1KBJ W1NI 2; W1BFS W1BGJ W1BUE W1CJZ W1CUH W1DF W1FKQ W1GCX W1HKF W1JBS W1JOR W1JTX W1JXR 1.
3.9- and 14-Mc. 'phone: W1SZ † 87; W1DWP 6; W1EAO 4.
1.7-Mc. 'phone: W1IMV 34; W1HLE-HSU 15; W1KAB 5; W1AQF 2; W1DAV 1.

Messages came from every district, and among the acknowledgments were messages expressing

* Includes five from W1CTI.

† Includes 10 from W1EEP.

loyalty, support, and felicitations, to A.R.R.L. and its President. We would like to list the calls of every ham who sent a message, but it would take more space than possible here. One message of special interest came from Michigan's governor (via W8GJK), the text as follows:

"It is a pleasure to pay tribute to the memory of Hiram Percy Maxim. The organization he formed and sponsored is deserving of congratulations and commendation on this anniversary. Its splendid accomplishments are universally respected."—Frank Murphy, Governor, State of Michigan.

In addition to the relay aspects of this commemorative activity, the program was a test of the coverage of these field organization stations both individually and as a group. Of course not all the listeners reached sent acknowledgments, but the coverage indicated is most satisfactory. Results of course depend on the number of transmissions made, the frequencies and power used, the time employed in the call to "collect an audience" and the like. The fact that some stations worked in "extra" transmissions, and that one station known to have sent the message on schedule five times received no reports at all indicate a condition of "competition" between stations transmitting—the louder stations or those best situated in the band perhaps producing the acknowledgments. At any rate, the list of reports on stations is here presented as a factual account of results as compiled from the messages received:

TRANSMITTING STATION REPORTS

3.5-Mc. telegraph: W1AW 136; W8AQ 24; W1BDIN8DME 19; W5AAX 14; W9IGZ 9; W3BWT 6; W2AAZV 5; W1BVR W5FZJ W8HWT W8JQE W9HPQ W9OEL 4; W3CKL W5DAQ W9BNT 3; VE3KM W1FPS W2ENZ W3EZ W6FBW W9HVO 2; VE1EH VESPL W1ASI W1BVF W1EEY W1FFL W61FE W7EMT W8AQS W8EEQ N8HPA W9IAW W9RVW W9SUE 1.
7-Mc. telegraph: W1AW 34; W8OFN 10; W3CDQ W9NUF 6; W9BYV W9KEI 3; W3BGD 2; W8AFE W9BYS 1.
14-Mc. telegraph: W1AW 11; W9CWW 2; W9DEI 1.
28-Mc. telegraph: W9GTO 1.
1.8-Mc. 'phone: W8IAI 44; W1IDY 4; W2ECO W2HFB W8DGL 3; VE3AHK W2IDZ W8GJM 2; W1CEA W1GZL W5DAD W8LFZ W6LPE W8FIP 1.
3.9-Mc. 'phone: W1SZ 27; W8LUQ 15; W2CBO W2DC 10; W8CKC 8; W1APK 7; VE2HT 6; VE3KM 5; W8JFC 4; W1HKK W8HFR 3; W2ACB W3EZ W4DGU W5BHO W8LIG W8LIQ 2; W1DWP W1EAO W2CBD W4QI W6ELW W6ETX W7FET W8DKP W9BUT W9RNX W9WC 1.
14-Mc. 'phone: W4DLH 20; W6AM 16; W9SDQ 12; W1SZ 9; W9RNX 7; W1GEX W6MLG W8CHT W9NGZ 3; W1HKK W3EZ W4QI W9RH 2; W1GZL W2FF W2IKV W8GUY W8HFR 1.
28-Mc. 'phone: W9GBQ 7; W1KH 1.
56-Mc. 'phone: W1KH 41; W2ACY 7; W1IDY 2.

The performance of the various amateur bands may be of interest, and indicative of transmission conditions and group response. Since the activity was all carried on progressively through one evening in making the president's message known,

(Continued on page 98)

"In the Public Interest, Convenience and Necessity"

A Detailed Account of the Amateur Emergency Work In the Flooded Ohio River Valley: January 21st—February 5th

By Clinton B. DeSoto*

On the desk before me lies a pile of notes, reports, letters, clippings easily ten inches high. Hundreds of individuals have contributed to that pile, each telling a story of high significance. Reduced to type, compiled into detailed manuscript form, this material would fill a dozen ordinary books—each crammed with epic achievement and the warm, tense excitement of great deeds done against difficult odds. It is the complete record of the amateur radio emergency work during the January Ohio River Valley flood.

From this incredible mass of data I have endeavored, in the following account, to distill the details of major significance and fit them into the general picture of the emergency as a whole. Obviously, the summary of so great a work in limited space must be sketchy and brief. The activity as a whole has, however, I think, been circumscribed, if not completely covered. Every effort has been made to include the call of every amateur station participating—and every operator, as well, for the cooperative spirit displayed by those who left their own stations idle to help in manning that of another was one of the finest features of the work. . . . But an end to tributes. Let us content ourselves with facts. They are, indeed, enough.

TO RADIO, sunspots bring DX; to most of the United States they brought a winterless winter.

To the Ohio River Valley they brought rain.

Off in the North Atlantic, like a giant, invisible Zeppelin, a slowly-moving circular air mass stalled. Stationary, it held in abnormal static fixation a train of other moving air currents that covered northern United States. Under the moisture-laden tropic air above the Ohio Valley crept a cold polar air-front, precipitating a deluge of endless rain.

Through most of the month of January the torrential downpour continued—falling at the average rate of nearly an inch a day in places. Water covered the countryside, running water covering the face of the earth, running down to reach rushing rivers, drowning out the very rivers themselves.

Sixty billion tons of water—a mass too great for the human mind to measure, a force too great for mankind to control—gathered in the tributa-

ries of the Ohio and then rolled slowly, relentlessly down the great river. Hour by hour, in savage crescendo, the crisis grew. State after state found its toes dipped in muddy yellow water that crept inexorably upward. One by one the old records were eclipsed—the while human minds, stultified by the overpowering horror of it all, strove vainly to anticipate calamity's end. Tolls of death and damage mounted higher and higher, until at the end there were hundreds upon hundreds dead, a million and a quarter homeless, property damage approaching a billion dollars.¹

NATION'S GREATEST FLOOD CATASTROPHE

It was the greatest emergency since the World War, said Admiral Cary T. Grayson, Red Cross head.

¹No complete official figures on death tolls exist; with censored "official" figures for Louisville—where for local reasons the true figures will never be known—the total is in the neighborhood of 400. The Red Cross reports 750,000 refugees in their care, a total of 1,250,000 homeless. Published property damage figures are entirely nebulous, there being no adequate method of computation and aggregation.



HIGH WATER . . .



. . . LEAVES DESOLATION

To say that is to make superfluous the statement that amateur radio, in providing emergency relief communications, made the greatest contribution to public service in its history.

From one end of the Ohio to the other, and along much of the Mississippi, existing communications systems were either broken down entirely or severely overloaded. From almost the beginning it was essential that radio step in. And from the very beginning radio amateurs were on



LEFT TO RIGHT: C. H. HOFFMAN, JR., W8HD, R. B. CREIGHTON, NDE-W8ALI, AND WM. W. LAMB, W8CXR, ALL OF WHEELING, AT NDE-W8AAO

the job, adding a helping hand wherever it was needed.

Through the early part of the week of January 17th the waters rose steadily. By the 20th the probability of a communications emergency became apparent. The next day the threat of a major flood became literal and a general mobilization began, with Red Cross, Coast Guard, American Legion, Army and other units preparing to aid civil authorities.

That day—January 21st—the two amateur military affiliates, the A.A.R.S. and N.C.R., were ordered into continuous active duty. At the same time, A.A.R.L. Communications Manager Handy directed the S.C.M.'s of eleven states to proceed with the organization of emergency nets in all affected areas. The West Virginia, Kentucky and Tennessee state traffic nets were placed on active duty, new recruits added at strategic points. Throughout the region informally-organized emergency networks swung spontaneously into action—the 4-Mc. 'phone net for the U. S. Army Engineers, the Northwest and the East Coast 160-meter emergency nets, and others. Where organized nets did not exist groups of stations cleared through central clearing stations, as on the 75-meter 'phone band through W8YX.

That night emergency traffic started to flow through the various organized nets in appreciable quantities. The work of lining up these other nets generated endless conversation. The bands began to fill with flood talk to overflowing. Through the weekend the pressure rose. Every station in the United States, it seemed, was on asking, "Can I help in the emergency?"

It was bedlam. On the "clear-channel" c.w. nets the traffic was forced through, although even they had their troubles. But desultory amateur work—especially on the 'phone bands—was often hopelessly jammed. Pleas for coöperation by the F.C.C. and the League abated the QRM somewhat, but not enough. Drastic action was required. It was taken on the afternoon of Tuesday, January 26th. The Commission, after a telephonic conference with League officials, issued the now historic "F.C.C. ban"² on all but emergency amateur operation below 4000 kc. A picked corps of sixty amateur stations was chosen by the A.R.R.L. Communications Department to broadcast the band and thereafter to serve as "vigilantes" in "piping down" offending stations and policing the bands.

INTERFERENCE ABATED BY F.C.C BAN

Almost immediately the QRM was cleared up, reported the beleaguered stations in the flooded zones. In a half hour it was largely dissipated; by nine o'clock that evening it was non-existent—except perhaps among the large number of emergency 160-meter stations located right in the valley, and occasionally on 75-meter 'phone. But by and large, the consensus of opinion goes, every channel was a clear channel, every contact "100



THE OPERATING POSITION AT WLH/W8GZ, WITH WINDY ON WATCH

per cent." Even the Canadian amateurs co-operated wholeheartedly, responding to the seven-times broadcast plea of Canadian General Manager Reid.

From that time on until the emergency was officially declared over, on February 5th, amateur radio provided a service of incalculable value to

² Actual text of the F.C.C. order: "To all amateur licensees: The Federal Communications Commission has been advised that the only contact with many flooded areas is by amateur radio, and since it is of vital importance that communication with flooded areas be handled expeditiously, IT IS ORDERED that no transmissions except those relating to relief work or other emergencies be made within any of the authorized amateur bands below 4000 kilocycles until the Commission determines that the present emergency no longer exists. By the Commission: John B Reynolds, Acting Secretary."

every official agency participating in the relief and rescue work. It is believed that some five hundred stations were active in the primary emergency zone (representing the affected states), manned by more than a thousand amateur operators, and that as many again stood more or less constant watch throughout the country aiding or waiting to aid in the relaying and dispatch of the emergency traffic. It is believed that perhaps 100,000 messages of an official nature were handled by these stations during the emergency period. It is believed that, almost without exception, every city and village and rural community along the Ohio River received greater or less benefit from this amateur work.

What these prosaic figures add up to in terms of lives saved or suffering averted none can say. Certain it is that death tolls now numbered in hundreds would have been in thousands had it not been for radio amateurs, that hundreds of thousands of the million and a quarter homeless would have experienced additional agonies of starvation or illness or mental turmoil had it not been for their work. Have you ever seen a man die? Have you ever seen a child suffer in torment? Multiply these by a thousandfold and you will begin to grasp the use of amateur radio.

We speak of amateur radio—but not in the sense that amateur radio alone served in the Ohio River Valley floods, or even that amateurs as individuals deserve credit far exceeding anyone else. It was a work of all Radio, with all services—military, broadcasting, police, Coast Guard, amateur—commingled into one whole, a surprisingly-unified whole. All types of stations worked each other, sometimes invading each other's frequency bands. There is no way of isolating credit or blame for the work performed, for all worked together, toward the same ends—brothers in the democracy of common need. No, all that was done we cannot claim for amateur radio.

But this we can claim for amateur radio: that again it was the great reservoir of trained personnel from which all services drew, for behind the operation of practically every piece of radio equipment of whatever origin participating in the emergency we find a licensed amateur—and that again it has been proved that through amateur radio all other radio in this country finds being.

And that is glory and to spare.

Pennsylvania:

The January, 1937, floods took over where the March, 1936, floods left off.

Pittsburgh last year experienced the greatest debacle in its history, bearing the brunt of the waters from the flooded Conemaugh, Allegheny and Monongahela rivers—the bottle-neck through which Pennsylvania flood waters drained off into the Ohio.

But this was an Ohio River Valley flood, and Pittsburgh was located precisely at its source. High water being a cumulative affair, Pittsburgh this year barely got its toes wet. Such communications emergency as existed was due to overloading of existing facilities and the difficulty of maintaining contact down the river.

Within the scope of this limited need Pittsburgh amateurs performed successfully. The most important activity was the organization of a 75-meter 'phone network, extended by other stations down the entire Ohio Valley, on behalf of the U. S. Army Engineers. Key station for the Pittsburgh office in this

set-up was Gilroy M. Barker, W8PX. He was linked to the 5-meter station at the Engineers' office in the Federal Building—W8BBV, operated by Harmon W. Armstrong assisted by W8BGJ—by a 160-meter relay through L. G. Fabian, W8GJM. Theodore Fabian aided in the operation of W8GJM. The Engineers' network was of the highest value. A considerable quantity of official traffic was handled via W8BBV-W8GJM-W8PX (W8PX also used the call WYDO on 4035 kc. c.w.) to W8CXR and W8YX, providing the engineers with required information on flood stages, etc., which enabled them to evacuate various communities before the water reached dangerous levels. Hourly river reports were transmitted for the period from January 20th through January 26th.

Charles Affelder, W8HLM, and Henry E. Schurman, W8DJE, also aided in the Army Engineers' network, as well as handling Red Cross traffic with W8YX as key station. W8DJE, where Stewart Dixon, Louis Luchardt and Ed Lips were assistant operators, secured flood reports from a river transportation company. Both stations used 4-Mc. 'phone. Henry Wickenhiser, W8KWA, and W. K. Thomas, W8QAN, also participated in the Pittsburgh work, on c.w.

Elsewhere in Pennsylvania a large number of



WM. R. HODGES, W8MOL, HUNTINGTON, WAS A MAJOR LINK IN THE U. S. ARMY ENGINEERS' CHAIN

stations were active, so great a number in fact that space limitations prevent individual descriptions of their work. The following calls have been noted, asterisks indicating apparently better-than-average work while the numbers show the wavelength-bands used:

W3ADE 80, W3ADM 80, W3ADN 80, W3AKB 80, W3AMD 80, W3BES (W3DMQ, W3CHH, W3AGV, W3KT, W3ENX, W3FLH, W3DRJ, W3COZ)* 80-40, W3BFZ 75, N3CHL 80, W3ECA 80, W3EOP/WLQB*80, W3ETM/WLQF 80, W3FFX 80, W3FXZ 80, W3NF* 75-80, W3OK/WLQA 80, W3QV 75-80, W3UA (W3ART)* 75-20, W3ZN (W3EMR) 80, W8BHN* 75, W8BRC* 75, W8BWH 75, W8CHT 75-20, W8CMP 80, W8FLA/WLQC* 80, W8HHO 80, W8HTX 80, W8INE* 80, W8IXC 75, W8KUN* 80, W8LMY* 75, W8LYK 80, W8NDE 80, W8OFO* 80, and W8UR 75.



HAROLD A. STURM, W8PTJ, IN THE N.C.R. NET AT HUNTINGTON

West Virginia:

Down from Pittsburgh the yellow water rolled. West Virginia and Ohio creeks and rivers added to the volume with a record 9.41-inch rainfall during January.

At Wheeling the river remained above flood stage for a full week. Wheeling Island, South and East Wheeling, were almost entirely evacuated—20,000 homeless, a third of the city inundated. Even so, damage did not compare with last year's flood, for the crest was seven feet lower, the current not nearly so swift. More than that, people were prepared, willing to accept any warning, however fantastic. They had had their lesson just ten months before. . . .

The communications emergency resulted only from overloading of wire systems, for these remained largely intact. But there was plenty of opportunity for Wheeling hams to serve—and they did.

At Wheeling Courthouse the N.C.R. station, NDE/N8AAO, was operated by Ensign A. B. Creighton, N8ADI, Ensign R. W. Lally, N8AAO, and Radioman G. A. Prostinak, N8LBI, assisted by other non-amateur Naval Reservists. A total watch of 181 hours was maintained, 161½ hours of it continuous, handling Coast Guard, Army and Naval Reserve communications, with a message total of 416.

C. S. Hoffman, W8HD, operated in the highly-efficient West Virginia State O.R.S.-A.A.R.S. net for 100 hours or more, handling Red Cross, A.R.R.L. official, and personal traffic. He also

coördinated Trunk Lines A, C and E for the period of the emergency.

The Wheeling station in the U. S. Army Engineer's network was W8CXR, 75-meter 'phone operated by Wm. W. Lamb, relieved by W8BTV. Three-quarters of the traffic handled during 56 hours watch was for the Engineers, the rest mostly Red Cross. A great deal of information on river conditions, instructions, etc., was transmitted on regular schedule.

Down the river the crisis grew more severe. The city of Parkersburg, with perhaps a quarter of its 30,000 inhabitants homeless, was isolated. To its aid went Herbert V. Romine, W8GDF, of West Milford, who hurriedly assembled several transmitters—consisting of 45 tubes as oscillators modulated by other 45's—from a serviceman's parts stock, and established stations on fire boats located in that city. This work unquestionably saved a number of lives. Returning

home, W8GDF secured his own transmitter and transported it back to Parkersburg, setting up and operating from WPAR. Several times he had to dismantle his station and move it by boat as the water climbed relentlessly higher.

Three miles from Parkersburg, at the transmitter building of WPAR, Ray Spence, W8BRE, using an emergency 160-meter rig, worked into a net composed of Marietta, Ohio, amateur stations. Naval Reserve communications at Parkersburg were provided by Ensign F. D. Masters, W8DNN, using the tactical call CE5C.

Elsewhere in West Virginia tributaries of the Ohio bulged with the abnormal rainfall and produced subsidiary emergencies. At Leon, W. Va., on the Kanawha, Clarence A. Casto, W8JJA, was the sole means of communication for that isolated community. Off the air for nearly three years, he hurriedly assembled emergency apparatus that enabled him to contact W8LII. He's coming back into the game now!

At Point Pleasant, W. Va., where the Kanawha joins the Ohio, the entire business section was under water and all communications lost. From West Charleston came Corporal Wm. D. Stone, W8MAO, with a portable rig using 35 watts on c.w., 20 on 'phone, with which he notified authorities at Charleston via W8DMF, resulting in the early dispatch via airplane of medical supplies. For two days this station provided communications for the Army, Red Cross, West Virginia National Guard, State Police, and State Board

of Health, the Army Engineers, Coast Guard, American Legion, WPA, telephone company, and others.

When Corporal Stone was called back to Charleston, John A. Kramer, W8LS, also of Charleston, took over. Sent on a relief survey by boat for the Red Cross, he had taken along his transmitter and receiver. Finding them badly needed, he stayed, set up on the judge's bench in the courtroom, and aided in the direction of relief communications handling 260 messages. W8JTW, on the other hand, who went into the city with emergency gear, was ordered out by local authorities.

Although not flooded, Charleston was the major refuge center of the state, and the amateurs there performed an emergency communications job deserving of mention. In this city W8CZ, although himself partially disabled, provided invaluable Red Cross contact. W8IRV and W8PMA assisted him. At the fixed station of W8MAO, located in the Armory, W8DMF handled quantities of relief traffic for various official bodies. W8PQQ relayed flood traffic on 7-Mc.; W8JQP guarded the 75-meter 'phone band. W8KYJ, also aided in the emergency work, as did W8PTX, 160, and W8OBA, 80.

It was in the 100 miles from Parkersburg to Huntington that the January flood transformed itself from just another flood into the country's major natural cataclysm of all time. From there on, the Ohio was a vast inland sea full of foam and mud and debris, an engine of death and destruction systematically and relentlessly scourging everything in a path often ten miles or more wide.

Faced with an emergency of the first magnitude, Huntington amateurs came through in typical ham style.

Functioning in the uniformly effective Army Engineer's network was W8MOL, operated on 4-Mc. 'phone by Wm. R. Hodges and XYL, assisted continuously by W8AHF. In 193 hours of operation 784 messages were handled, two-thirds for the Engineer's (their river telephone lines were broken, although other wire systems into Huntington remained intact), the rest being Red Cross, American Legion, police and about 100 personal messages. This does not count 1500 additional contacts involving official information.

An active N.C.R. station was W8EZR, owned by F. D. Reynolds, who, as the flood waters engulfed his home, moved his equipment to the

telephone building and, aided by W8BDD, operated there until an accident beyond their control rendered the equipment inoperative. Meanwhile they handled 386 messages, provided weather reports and aided the telephone company to maintain contacts with branch offices. Radioman Harold F. Sturm, N8PTJ, first handled personals in the ham bands, then Red Cross and Engineers' traffic. Water threatening his home, with the aid of W8DUO he moved his rig to the City Hall, where it was taken over and manned by the Coast Guard for two days.

Lieut. Ramey, N8PSR, operated in the A.A.R.S., W. Va., and N.C.R. networks at times, although his principal job, as Communications Officer of Units 2 and 4, was in coordinating local communications activities, as well as organizing blinker systems in cooperation with the State Police for use in isolated sections.

Out in Guyandotte, completely inundated suburb of Huntington, T. E. Bobbitt, W8LJX, was the sole communications link after telephone service went out. He operated on c.w. continuously for some days, handling 336 messages even though under a physician's care with influenza, serving the police and Coast Guard with vital information.

Arthur Wolf, W8DGG, traveled to Huntington from Williamson and set up a station at American Legion headquarters there, scheduling G. K. Ball, W8OFG, at Williamson, for the purpose of enabling the Legion to control dispatches of men and supplies for relief work, as well as directing transportation of refugees.

Active also in Huntington, until overcome by influenza, was George H. Gunnoe, Jr., W8MEK. R. W. Nixon, W8BDD, and Wm. J. Parker, W8OIC, built a 160-meter 'phone rig which was used for police patrol work; W8WK's 'phone was used for the same purpose. W8OIC was also active at his own station, as were Lee F. Lister, W8MQF, and Wm. C. Toney, W8MZT, 160-'phone.

Throughout West Virginia other amateurs were on at all hours of the day and night, many of them working in the West Virginia State net. This net is a

combination A.A.R.S.-A.R.R.L. net, working as an Army unit Monday nights and as an O.R.S. group the rest of the week. W8KKG/WLHP, Dr. W. H. Riheldaffer, S.C.M. for the state, heads it. The other stations were W8CFB/WLHF, W8MCL/WLHQ, W8AKQ, W8LLI, and W8NAU, as well as those previously mentioned.



FROM THIS ROOF JOSEPH P. KENNEDY, JR., W8MRU, AND HIS FAMILY BOARDED A COAST GUARD BOAT AFTER OPERATING HIS EMERGENCY STATION UNTIL WATER ALMOST REACHED THE CEILING OF THE LOWER FLOOR (WATER LEVEL MARK IS VISIBLE)

W8BOK, 75, W8ATT, 160-80, W8DMU, W8PNE, W8QJS, W8ELO, and W8LXF, complete the roster of West Virginia amateurs recorded as active in the emergency.

Ohio:

Rivers have no gratitude. To the state to which it owes its name the Ohio River last January brought holocaust and destruction, smashing first the 1913 record, then topping the disastrous flood of 1884.

First warning of the emergency came to Marietta amateurs on Sunday, January 23rd, when they discovered that telephone service to Pittsburgh had been cut off by the rising waters. Receiving a plea for aid via 160-meter 'phone from W8BRE, located at the WPAR transmitter across the river, H. F. Babb, W8OIL, lined up a network in which Carl J. Anderson, W8VZ, handled local and out of town messages, while Charles Clarke, W8KWZ, W8OIL and W8KYC, the Marietta Amateur Radio Society's station operated by club members, handled local traffic.

To flooded Gallipolis (tell this to O. O. McIntyre) went Rod Meany, W8JTW, with his emergency gear, after officials had ordered him out of Point Pleasant. Operating at the sheriff's office in the county jail, Gallipolis, assisted by George Bovie, he handled the city's emergency traffic on 75-meter 'phone.

All along the river the water rose. Past Huntington, at Ironton, on the Ohio side, W8EUN carried on with relief communications until the high water drove him from his home. Then the National Guard station, PG, took over.

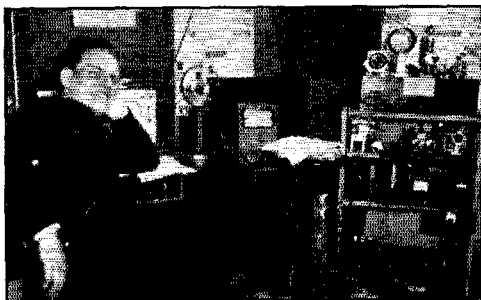

TAKING IT EASY AFTER ELEVEN DAYS' WATCH, RICHARD WRIGHTSEL, W8KYQ, PORTSMOUTH, IS SEEN WITH HIS EMERGENCY LAYOUT

Further on, at Wheelersburg, Russell W. Banks W8PGL, aided by W8PFT, provided the only contact for a community cut off for a full week after the flood crisis. Operating on 75-meter 'phone at times from a 32-volt converter powered with banks of freely-contributed automobile batteries, this station secured all supplies and aid for the flooded communities of Wheelersburg, Allen Township and Sciotoville. Warning was also given

lower cities of thousands of gallons of gasoline which flamed the river water forming a gigantic fire hazard.

Just down the river, at New Boston, Ohio, Clyde Meadows, W8NSV, 1920-kc. 'phone and

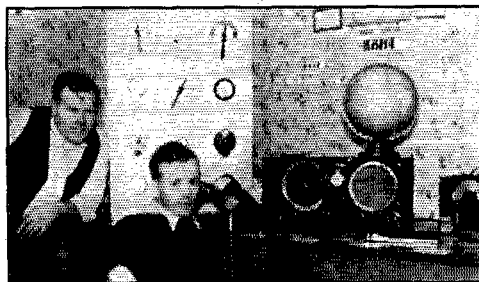

W8PGL, WHEELERSBURG, SOLE MEANS OF COMMUNICATION FOR SEVERAL ISOLATED COMMUNITIES

Standing, Russell Banks, W8PGL; seated, Joe Price, W8PFT, relief operator.

Wm. E. Adkins, W8DIX, 8-Mc., performed from the start of the emergency until power failed on January 24th, on behalf of the State Patrol, Division of Conservation, Red Cross and City Police.

Portsmouth—"the city of refugees"—bore the maximum brunt of the flood. Thinking themselves safe behind their 62-ft. levee, the citizens watched the Scioto, tributary of the Ohio, rise until it became a vast mile-wide lake. With sudden dismay they realized their vaunted sea-wall would not save them. Sewage gates in lower sections were opened, with the hope of saving the rest of the city. But the water rose interminably, covering their levee waist-deep in swirling yellow water.

Thousands of people had to be evacuated—instantly. Telephone service was largely out. Only radio remained.

From January 21st through February 4th W8DQM was on the air on 3950 kc. 24 hours a day, except for four hours in which the station, threatened by high water, was moved. It was manned by Vernon C. and Glenn Warnock and W8KVF. A total of 2376 written messages was handled, not counting large quantities of orally-relayed information. The station's principal activity was in the Army Engineer's network, but it regularly scheduled a dozen other stations and tied in with half a dozen local agencies, providing a strikingly effective local network.

H. E. Saylor, W8DHD, assisted by W8BTB and Harold Price, operated on 14 Mc. as emergency police station when the regular equipment failed, rebroadcast on 2430 kc. by John P. Bauer, W8CCS. Many marooned persons were saved through this operation. In addition to working into the local amateur network, calls were also sent to receivers at boat landings, health and

safety notices broadcast to the public, etc. A total of 2800 messages were handled in eight days of continuous operation.

Richard Wrightsel, W8KYQ, aided by Jack Augustine, operated throughout about the same period as W8DQM, handling most of W8PGL's traffic from Wheelersburg. Through WPAY, the cooperative Portsmouth broadcaster, delivery of local traffic from the amateur stations was greatly expedited. W8KYQ's message total approximated 500.

Operating on behalf of the Ohio National Guard in Portsmouth was Joseph B. Kennedy,



UNIVERSITY OF CINCINNATI'S W8YX
IN ACTION

Jr., W8MRU. He used battery power at his home until water almost touched the first floor ceiling, whereupon the Coast Guard transferred his gear to the Franklin Avenue M. E. Church Tower. There he carried on. At times when power was off W8MRU was the only station operating in Portsmouth.

The steamer U.S.S. *Kentucky*, stationed at Portsmouth for a time, which operated under the calls WZBA and W8MGR, was operated by Cincinnati hams—W8MQR, W80DU, W8PBE.

Down the river at (Believe It or Not) Ripley, Ohio, completely isolated, an unusual communications set-up operating under the call W8FKX comprised the old 160-meter transmitter of Charles W. Boyd, ex-W8EGU, and the receiver from a portable station brought into the region by T. Ross Liming, W8LCK, at the request of the Ohio State Highway Radio patrol. R. W. Bloss, W8KFX, owner of the call, operated the station. Combined with this, a Western Union office and a temporary Bell Telephone exchange were set up at the same location, Boyd's home (where tradition has it Eliza of "Uncle Tom's Cabin" found refuge after crossing the ice).

Outside of Paducah, the devastation at Portsmouth was probably more complete than in any other of the larger cities along the river. But many smaller communities were almost entirely wiped out.

One of these was New Richmond, to which with emergency equipment went Eugene W. Klein, W8UW/WLHI/FX, from Batavia. Working in the National Guard and A.A.R.S. nets from New Richmond hill and later at Bethel, he assisted in dispatching rescue boats and supplies, and also warned of escaping gas tanks on the river.

These floating gas tanks brought alarm to Cincinnati, but it was a small fear barely penetrating the numbness that followed the rise of the river to 70, 74, then 79 feet. Safe on its hills, Cincinnati proper tried to absorb 65,000 homeless, watched the water rise to depths of 20 ft. in the streets along "The Bottoms," wondered where it would end.

No matter where it would end, W8YX, the amateur station of the University of Cincinnati was prepared. Faced with a possible loss of power, Prof. W. C. Osterbrock, Chief Operator C. E. Grinstead, W8LNLK, and Richard E. Walker, W8BRQ, connected up two 15-kva. tractor-driven alternators and waited. But the power did not fail. Meantime, secure on high ground, the staff of 15 operators served for 15 days as the central traffic-clearing station in the 4-Mc. 'phone band for the entire flood zone. Messages totalling 2139 were handled, 90% of them official. Regular schedules were maintained with 36 stations, with innumerable additional contacts, nearly a dozen receivers were used to continually monitor various bands, including 56 Mc., 7 Mc., A.A.R.S. and 3.5-4 Mc. amateur channels, 160 meters and the b.c. band.

Key station in the U. S. Army Engineer's network for the entire lower valley was W8FIC,

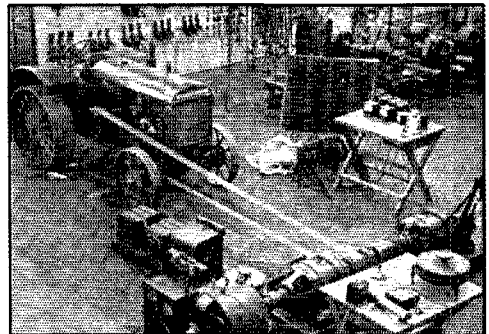

THE EMERGENCY POWER EQUIPMENT SET UP
AT W8YX, CINCINNATI

The McCormick-Deering tractor drove two 15-kva. alternators.

operated by Roger A. Burrus, assisted by Walter Wilks, W8NMS. W8NUP, W8AEH, W8JFC, W8EDX, W8FHW, W9FS, W8NLQ also operated. This station controlled the proceedings of various river boats used by the Engineers, as well as contacting the other amateur stations in the network on schedule.

W8MGD, operated by Corporal Geo. E. Dively, Corporal Ray Murphy and Private Howard Goodrich, assisted by Lieut. George B. Hart, was the National Guard station in Cincinnati, operated at the Freeman Ave. Armory. Among other feats, this station assisted in the evacuation of 2100 refugees from New Richmond.

The Cincinnati N.C.R. unit was, of course, on the job for the entire period of the emergency. At NEG/W8NC, three operators and one officer under the command of Section Commander Lieut. Elmer H. Schubert, W8ALW, were constantly on duty. At the Naval Reserve Armory other operators manned stations W8ALW-W8CCT and NEG1, while on the motor launch U.S.S. *Winifred* W8DSR and NEGA were operated on 3555 kc. and 60 Mc. Finally, Lieut. Schubert used a Navy portable under the call AX9B on a motor launch on the river for four days.

Other Cincinnati amateurs were effectively active. Jacob W. Schott, W8FGX/WLHR, handled Red Cross and police traffic, working in the A.A.R.S. network. Nicholas M. Glaug, W8NMR, pinch-hit in the National Guard net at times, handled some personals including one for filmmaker Robert Montgomery, and aided generally. J. W. Klotter, W8LPD, operated on 160-meter 'phone, as did James W. Ringland, W8JIN, Ivan L. Heavey, W8MGN, and Wm. Thren, W8FN, at Cheviot.

In connection with Army Engineers activity, there is to be listed Harry S. Gantz, W8QMN, Paul Fisher, W8LOD, and Leonard Ball, W8OII, all of whom operated on the U.S.S. *Scioto*; and John M. Hohman, W8MGR, Chris C. Pfitzer,



W9ELL, LOUISVILLE, OPERATED BY BOB LA-VIELLE ON 75-METER 'PHONE UNTIL POWER FAILED

W8ODU, and Glenn Walker, W8PBE, who operated on the U.S.S. *Kentucky*.

A number of unidentified 60-Mc. stations performed useful local service in the Cincinnati area for the Red Cross. W8FAY was established as a base for this work in the center of the city.

At Columbus, the state capital and also the center of the Ohio radio networks, amateur radio activity naturally reached a high point. Loren G.

Windom, W8GZ/W8ZG/WLH, who is Chief Radio Aide of the A.A.R.S., served as N.C.S. during the emergency and bore a heavy load of responsibility. His own message total of 801 was made up very largely of government and Red Cross traffic. He was relieved as N.C.S. by Dana



THE OPERATING POSITION AT W9AUH, LOUISVILLE

The station was powered by two gasoline-driven generators for the duration of the flood.

A. Young, W8BBH/WLHA of Columbus—who handled 270 messages—as well as by W8AFZ/WLHY, W8UW/WLHI, aided at times by W8JC/WLHN, W8CMI/WLHH, and W8CIO/WLHC.

W8LEK, operated by Charles K. Walker, W8HXQ, W8FXN, W8FYS, W8HHU, W8NPF and W8OVB, had a message total of 847 on 75-meter 'phone. Coöperating with the National Guard and other relief agencies, as well as broadcaster WHKC, this station centralized emergency communications in general for the State of Ohio.

The Ohio National Guard control station at Columbus, which operated under the call AB, used amateur frequencies and equipment and was manned by amateur operators. Working both c.w. and 'phone, a total of 450 messages were handled by W8IJV, W8IZQ, W8FJN, W8JBI, W8JHE, W8LPN and W8ISK/WLHO. W8CKG and W8VE were also associated with the work of the station.

Also active on 75 meters in Columbus were W8EQV and W8OVB. On 160 meters there were W8BBH-80, W8IMB, W8BPE, W8HAM, W8NBO and W8OLO. W8BBH and W81MB were on 80. James D. Brewer, W8DGG, operated on 7 Mc.

Throughout the rest of Ohio the number of active stations was so great that, again, space limitations permit the listing of calls and bands only: W8APC 80, W8AQ 80, W8ARO (W8DHS)* 80-40, W8AZH* 75, W8BAH/AX9G 80, W8BMU 75, W81CC 80, W8CIO/WLHC* 80, W8CMI 80, W8CNC 80, W8CTP 80, W8CVZ 75, W8CZR 80, W8DKK 80, W8DL 75, W8DPM 80, W8DUV (W8OVO, W8ORO, W8GXR) 75-20, N8EJ (N8FRY, N8WB, N8OYO, W8CGP, W8UX)*

75-80, W8ESN (W8GJS, ex-W4DPK, W8KPH)*
75, W8FAR 80, W8F DU 80, W8FHB 80, W8FSK
(W8LNC, W8IBN, W8QIE) 75, W8FVW 160,
W8GGI 160, W8GSO 80, W8HCS 80, W8HFR
75-160, W8HMH 80, W8IAI* 160, W8IAW 80,
W8ICC 80, W8JFC 75, W8JMJ 80, W8JVN*



LIEUT. BEN J. BIEDERWOLF, N9VAI, JOHN E. McCUTCHAN, W9MOK, AND PHILIP E. HATFIELD, W9GFS, ALL OF EVANSVILLE

160, W8KIM 80, W8KVF 80, W8LCY 80,
W8LPD 80, W8LZE 80, W8MEI 80, W8MFV
160, W8MQO/WLHS 80, W8MWH 160,
W8MWL (W8BMU)* 75, W8MXW 80, W8NAL
80, W8NKU 80, W8NLZ 80, W8NPE 160,
W8NPP 80, W8NQZ 80, W8NYP 160, W8NYY*
160, W8OHP 80, W8PEX 80, W8PL 80, W8PNP*
160, W8PUN* 160, W8PWY-PZA 80, W8PZO
160, W8QC 80, W8QKN 80, W8QPQ 80, W8QV
80, W8VZ 75, W8WE 80,
and W8WY 80.

Kentucky:

The Ohio River, they say, is a thousand miles long. For more than half its length it provides the northern border of the sovereign State of Kentucky.

Kentuckians often believe no good can come from the North. Last January they may have had reason for the thought, for in their half of the Ohio it roused to peak fury—leaving behind more than 300,000 homeless, hundreds dead, and property damage of many millions.

Defying havoc-dealing Nature, a few-score radio amateurs occupied front-line trenches in the defensive battle in which the nation joined.

Near Ashland the Ohio leaves West Virginia, joins Kentucky. So badly hit was this region that for a time supplies were delivered by parachutes dropped from airplanes which flew down from

Columbus by request at frequent intervals N9HNV, on 75-Mc. 'phone, was the Ashland link in the U. S. Engineer's network, as well as guarding N.C.R. frequencies and serving the Red Cross, National Guard, etc. It was operated by J. Lynn Rhodemyre, aided by W9BEW and N.C.R. Unit personnel including W9GAQ, W9JDI, W9WUR, Ed Carr and Ray Glancy. All Red Cross supplies from Columbus—delivered by airplane—were ordered through this station, and all relief traffic along the river between Ashland and Portsmouth through W8DQM.

On 160 meters Harry J. Harris, W9WXL, relieved at times by W9WUR, performed a wide variety of services, including a relay through W8NYY to Dayton requesting the parachute deliveries mentioned above. Working W9TXC, this station was for a time the principal relay point for official Louisville traffic. W9JDI and W9TKO, both on 160, also aided in the Ashland work, as did Ernest V. Herrider, W9VYY.

Elmer G. Leachman, in addition to relief operation at other Ashland stations and hitches at WCMI, operated his own station, W9BEW, in the A.A.R.S. 75-meter 'phone net which stretched from Huntington to Cincinnati, as well as 3810.

Continuing along the Kentucky shore, beyond Portsmouth at Maysville, E. S. Young, W9AEN, and J. E. Manion, W9YHD, provided emergency communications facilities, not only for Maysville but many surrounding communities. W9AEN, on 75-meter 'phone, transmitted urgent Red Cross traffic to Washington; aided by Leslie Bennett and George Yazell, W9AEN served as police radio and local broadcast station, as well as for the National Guard, Coast Guard, etc. W9YHD, on 160, handled some official and much personal traffic, including files of messages for Western Union.



IN DRIVING SLEET, THE TEMPERATURE 12° ABOVE ZERO, W9MWC STARTS OUT WITH HIS RADIO GEAR ACROSS A TREACHEROUS MILE OF SWIFT WATER IN HIS HEROIC ATTEMPT TO REACH SHAWNEETOWN

On the Kentucky side of the river near Cincinnati, to be mentioned are Bert Brown, W9FS, who operated his own station on 80 at Newport for the Red Cross with a direct line to Cincinnati until power failed and then stood watches at W8FIC, and Albert M. Barnes, W9EDQ/WLHT, who operated in the Kentucky State and A.A.R.S. nets from a special power line to the City Building in Ludlow after being flooded out of his home, handling nearly 500 messages with the aid of W9TLZ and George Hill, ex-Navy op, and W9NAR. Control station of the Kentucky Net, he handled mostly Red Cross and police stuff, maintaining close contact with police.

Remember the dramatic newspaper stories of the tense scenes at Frankfort, as 1500 families took to the hills when the state capital flooded and the 2900 panic-struck prisoners in Frankfort Reformatory revolted? Well, it was an amateur group associated with a broadcast crew that provided Frankfort—and the Governor of Kentucky and his staff—with emergency communications.

Providing the Kentucky Net's principal contact with Frankfort was Carl A. Newman, W9AZY, sent from Louisville. Undaunted by power failure, he set up an emergency rig built from an old condenser tester, and that buzz saw carried the traffic of the Governor and Adjutant-General.

Realizing Frankfort's desperate state, on the 23rd Henry Hall, W9MGT, D. E. Farmer, W9MWR, and Asa Adkins, W9VBO, along with Sanford Holt, chief engineer of WLAP, set out from Lexington with emergency equipment. An 8-meter b.c. pick-up unit was set up at the relief chairman's office in the courthouse; two miles away, in the State Capitol, W9MGT operated on 4-Mc. 'phone and in the Kentucky net. After an initial period of operation in Frankfort, W9MWR returned to man his own station at Lexington, working in the Kentucky net, aided by W9CRJ, W9IFM and E. L. Darsey.

On January 22nd WHAS, Louisville, broadcast the information that Carrollton, Ky., pop. 2500, half-way between Cincinnati and Louisville, was isolated, added a plea for an amateur to go there with emergency equipment. W. O. Bryant, W9NKD, answered the call and thereupon became one of the flood's ham heroes. Aided by Charles Carter and Eugene Moore, W9NKD was met by boat, set up his gear, and for ten days was the only communication means available to the Army, Coast Guard, Red Cross, and the mayor of Carrollton. 'Phone on 75 and 160 was used, with 20 watts power. Best performance: Getting ambulances for emergency operations from Madison, Ind. (via W8YX); average time, 30 minutes.

The toll of the flood in Louisville will never be known. The horror of those days and nights will never be told.

Even the full record of the amateur radio emergency work in Louisville will never be established. . . . Hundreds dead, 230,000 homeless, disease, fire—a river crest of 56.9 feet, everything within the city limits flooded, water two to six feet deep in all the principal streets—power gone, homes flooded, yet dozens of radio amateurs carry on, somehow, someway. . . .

It was all too big—too big to be visualized, even believed.

The early loss of power at Louisville created a situation whereby there were many operators available, few stations in commission. Some form of cooperative organization was patently essential. By mutual agreement, general responsibility in this direction was assigned to Lieut. W. R. R.

LaVielle, N.C.R., who until power failure had maintained consistent watches on the 75-meter 'phone band under his amateur call, W9ELL. Aided by L. N. Whitfield, he there handled 187 messages in the Kentucky, N.C.R. and 'phone nets. After power failed, from his office at the airport he directed and coordinated the operation of the half-dozen Louisville stations with self-



ROBERT T. ANDERSON, W9MWC, WITH THE RADIO EQUIPMENT HE TOOK TO SHAWNEETOWN

The transmitter is his regular exciter, 6L6 oscillator-doubler to a single Type 10; the receiver is a battery-operated 6-tube all-wave set.

power, secured gear, supplies, and relief aid, and in general made the system work.

Using battery power and later two gasoline generators shipped from Chicago for use at W9ELL but inadequate to handle the kw. 'phone load, G. W. Mossbarger, W9AUH, carried on after power failure to handle 443 messages, working in the KYN and N.C.R. As Kentucky's S.C.M., his was also the job of coordinating state-wide communications, with special emphasis on the Kentucky net.

On with battery power immediately after power failure, and later with a gasoline-driven a.c. generator, W9FQQ, operated by John M. Gates, Jr., W9HZL and W4DDZ/9, provided a consistent 80-meter traffic outlet. Of the 318 messages handled, a third were in connection with WHAS, a third for official agencies, and a third personals. WHAS characterized the work as "of inestimable value."

Operating on 75 and 160-meter 'phone, Glen Cook, W9TXC, with W9LZS and W9UXT relieving, used emergency power from a Delco 32-volt plant driven in by W9LZS over 160 miles, which in turn operated two 32-v.d.c. to 110-v.a.c. generators—with an S8 background of hash! A total of 274 messages were handled, many of vital importance. On January 30th the transmitter was pressed into service to replace the defunct Louisville police radio station, being remotely-controlled from the City Hall five miles away.

Robert C. Berry, W9MN, with battery power,

(Continued on page 78)

Directed Vertical Radiation with Diamond Antennas

14-Mc. Rhombic Systems with Steerage Control to Suit Transmission Conditions

By Morton E. Moore,* W6AUX, and F. L. Johnson,** W6CNX

IT HAS been shown by E. Bruce and A. C. Beck¹ of the Bell Telephone Laboratories that by altering the physical shape of a rhombic or diamond antenna, the radiation pattern of the antenna in the vertical plane may be changed, the effect being to rotate the radiation pattern through a limited region in the vertical plane, without essentially altering the horizontal pattern. An antenna so designed that its configuration may be altered is said to have "Steerage Control." In other words, its vertical radiation may be steered at will. To take advantage of this, the supporting poles are set back some distance from the apexes of the wires in order that the physical shape of the antenna may be changed by adjusting the halyards. Provision should be made for altering the distance between the end apexes by at least 10%.

The antenna systems² used in the tests to be described consisted of two horizontal rhombic antennas (more commonly known as diamonds), operated on 14 Mc., each $3\frac{1}{4}$ wavelengths on a side, approximately a wavelength above ground, and terminated in their characteristic impedance.

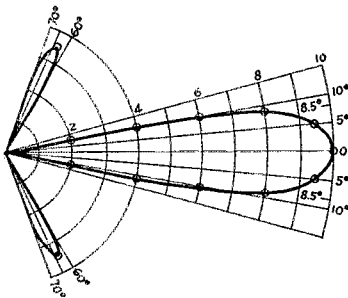

FIG. 1—RADIATION PATTERN OF THE HORIZONTAL RHOMBIC ANTENNA IN THE HORIZONTAL PLANE

$H=1$ wavelength. $L=3\frac{1}{4}$ wavelengths. $\theta=58^\circ$.

The major lobe and two largest parasitic lobes are shown.

The typical radiation patterns are shown in Figs. 1 and 2. A schematic diagram of the construction is given in Fig. 3 and the constructional diagram

*1418 No. Spaulding Ave., Hollywood, Calif.

**1219 No. Beachwood Drive, Hollywood, Calif.

¹ Bruce & Beck, "Experiments with Directivity Steering for Fading Reduction," April, 1935, *Proc., I.R.E.*

² These same antennas were used by W6CUH, as described in Part II of his article "More DX Per Dollar," in March *QST*.—EDITOR.

is shown in Fig. 5. The two antennas were directed along great circle paths, one being aimed westward at South Africa, the other being aimed north by northeast to Europe. Each antenna was supported on four sixty-five foot poles, and fed by a 600-ohm two-wire open transmission line, the feed line for the South African radiator being some 350 feet in length. Since, when correctly terminated, a horizontal rhombic antenna of the dimensions of the ones employed presents an impedance of slightly less than 800 ohms at the sending end, if the antenna is connected directly to a standard 600-ohm feed line a mismatch of impedance will result. This will in no way affect the performance of the antenna for transmission,

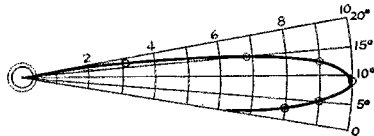

FIG. 2—VERTICAL RADIATION PATTERN OF THE HORIZONTAL RHOMBIC ANTENNA

Height, length and tilt angle are the same as in Fig. 1. Only the major lobe is shown.

though it will introduce standing waves on the feeders. For reception, however, reflection at the sending end of the antenna will ensue. The magnitude of these effects is slight and for most purposes may be forgotten. If one desires to establish perfect conditions for one frequency, an impedance transformer consisting of a quarter-wavelength transmission line ("Q" matching system) should be installed. The surge impedance of the matching transformer is given by

$$Z_0 = \sqrt{Z_R Z_S},$$

and will be greater than that of the feed line (Z_S) and less than that of the antenna (Z_R). The one employed by the authors consisted of No. 12 wires on 12-inch spacers.

Aside from the terminating impedance, the construction of the diamond is simplicity itself. The terminating impedance should have the properties of a pure resistance and should possess the ability to dissipate energies ranging from a few microwatts up to several hundred watts, without change of impedance, in order that the antenna may be used both for transmission and reception without change of characteristics.

These limitations remove from consideration such terminating devices as incandescent lamps, because of their temperature coefficient of resistance; and wire wound resistors, because of their very appreciable inductive reactance at high radio frequencies. The ideal terminating impedance would consist of a bank of large carbon resistors, large enough to dissipate several hundred watts without heating. A value of about 780 ohms will be found satisfactory in most cases for the terminating impedance, although after checking this may have to be altered. At the time of construction, such resistors were not available, and a cheap, practical substitute was sought. The problem has been solved by commercial communication companies by the use of transmission lines constructed of iron wire, shorted at the end, and extending a distance of several thousand feet from the antenna. But such a line was not feasible in this case. It is understood, of course, that the purpose of the terminating impedance is to dissipate the energy which would otherwise be reflected back along the antenna. This will be treated in more detail later.

To terminate the antennas, open wire transmission lines of 783 ohms surge impedance were constructed employing No. 25 nichrome wire spaced 6 inches, the resistance of the line dissipating the energy. To simulate an infinite line, the lines were terminated in 785 ohms of carbon resistors at a point 200 feet from the antenna, the energy level at the end of the line having been determined to be of the order of 60 watts with full 1-kw. power input to the antenna. The phase angle of the line, as determined from the equation

$$Z_0 = \sqrt{\frac{R + j\omega L}{j\omega C}}$$

was found to be approximately 3 degrees. Hence the line could be considered as presenting a pure resistance to the antenna. It is now possible to obtain suitable carbon resistors³ for this purpose, which might be incorporated into the antenna in the last few feet at the far end, thus obviating the necessity for a dissipating line.

The relation between the interior tilt angle δ and the length of the sides of a horizontal rhombic

³ Carborundum Co., Niagara Falls, N. Y.

antenna is shown in the graph of Fig. 4. In the course of changing the terminating impedance, it was noted that the radiation pattern of the antenna in the vertical plane was materially affected by these changes. This observation was made with the South African antenna, which had been in use some three weeks, and with which

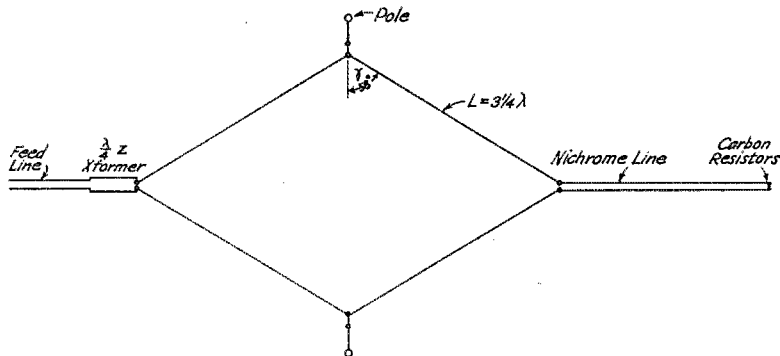

FIG. 3—SCHEMATIC DIAGRAM OF THE RHOMBIC ANTENNAS USED IN THE TESTS

regular daily schedules had been maintained with 88 reports. Upon changing the terminating impedance to its correct value, we were unable to contact any South African stations in the following two days, and it was reasoned that the radiation pattern had been altered by this change. We then changed the physical shape of the antenna so as to raise its radiation pattern in the vertical plane. This was done by elongating the antenna, and the following morning we contacted five South African stations with 89 reports from all of them. It was also noted that the back end reception had dropped considerably.

With these observations as a basis, we set upon a systematic survey of the results to be obtained by raising and lowering the radiation pattern in the vertical plane. Tests were conducted with numerous stations in both South Africa and Europe over a period of more than four months. The procedure was first to set the antenna at an adjustment which had given consistent results in the past. Upon contacting a station, the radiation pattern in the vertical plane then was lowered to its position of lowest angle radiation and gradually raised during the course of the test until it was in the position of highest angle radiation possible with the set-up used. With but few exceptions the results showed that:

1. At the lowest angle of radiation the signals were either entirely absent or extremely weak at the receiving end.

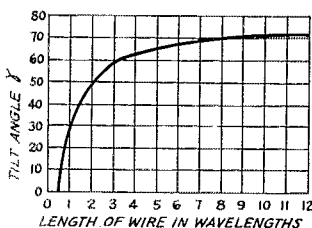
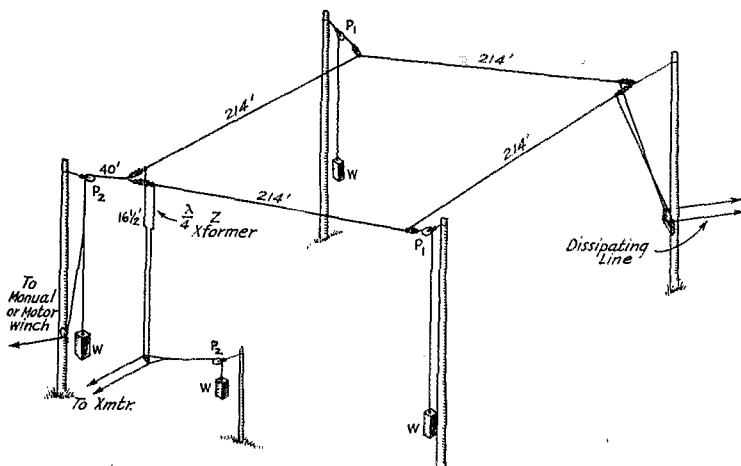

FIG. 4—CURVE FOR OPTIMUM TILT ANGLE FOR WIRES OF VARIOUS LENGTHS



The Antenna is shown with the control rope let out as far as possible

Height above ground = 65'
 Length of sides = 21.4'
 Objects marked W are Counter weights
 Pulleys P₁ should have 6" sheaves and good frictionless bearings
 Same for pulleys P₂ except that frictionless bearings are not absolutely essential.

$\frac{1}{2}$ Z Xformer 16 $\frac{1}{2}$ ' long
 Spacing = 12" No. 12 A.W.G. Wire
 Dissipating Line - No. 25
 Nichrome spaced 6"
 Antenna and feed lines constructed of No. 12 A.W.G.
 Hard Drawn Enameled Copper Wire
 Feed Lines spaced 6"
 Normal Length = 360'
 Normal Width = 231'

FIG. 5—CONSTRUCTIONAL DIAGRAM OF THE 14-MC. RHOMBIC ANTENNAS WITH MECHANICAL ARRANGEMENT TO VARY THE TILT ANGLE FOR STEERAGE CONTROL IN THE VERTICAL PLANE

2. That upon reaching a certain definite critical angle in the vertical plane the signals suddenly increased in strength to S9.

3. That as the radiation pattern was raised still further the signals remained practically constant for some time and then gradually fell off in strength. This is exactly what would be expected if the region of useful transmission were confined to a very limited region in the vertical plane, when studying the phenomena with an antenna which possesses a sharp cut-off on the top side of the radiation pattern and a broad cut-off on the under side, as is the case for the antennas used. The tests indicated that on 14 Mc. the useful region of transmission was under 25 degrees and for 7 Mc. under 40 degrees, above the horizon, which confirms the observations of other observers. Under abnormal conditions exceptions were noted in that there were apparently several paths of transmission. These conditions were almost always characterized by very noticeable fading and echo at the receiving end.

Messrs. Bruce and Beck¹ have demonstrated that there is an optimum vertical angle for reception, and at times when there are several paths from transmitter to receiver, by employing antennas of high vertical directivity, signals from some paths might be sharply discriminated against, and fading reduced, if the vertical pattern

is "steerable." The authors also noted this effect, and attempted to determine whether there was any relation between the optimum angle for transmission and the optimum angle for reception. The vertical patterns of the antennas employed were not sharp enough for an exact determination, but the results did show that the two are contained in a fairly narrow region, although not necessarily the same. Upon correlating the results of the observations we arrived at the following conclusions:

1. That, just as for reception, so likewise for transmission there is an optimum angle in the vertical plane.
2. That the optimum angles for transmission

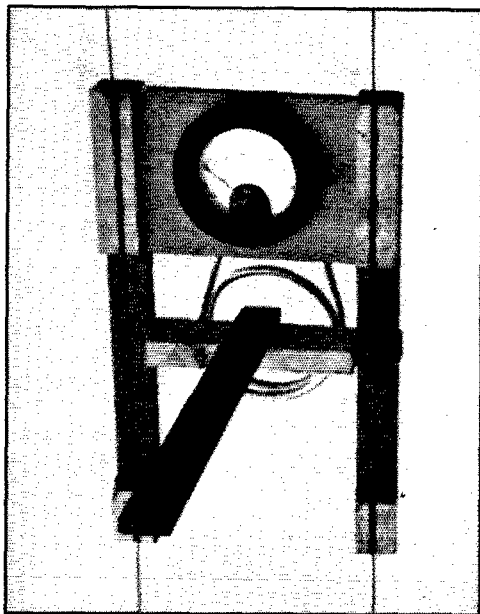

THE "TROLLEY" DEVICE FOR DETECTING UNBALANCE AND STANDING WAVES ON THE FEEDER AND TERMINATING LINES, AS DESCRIBED IN THE TEXT

and reception are close together although not necessarily coinciding.

3. That there is, under normal conditions, but

a very limited region in the vertical plane in which useful radiation takes place, and that energy directed into any other region in the vertical plane is largely wasted.

4. That the optimum angle of transmission changes from time to time with changes of season and conditions, but that there is no material change within a given short interval of time.

5. That *controlled* directivity in the vertical plane is relatively more important than directivity in the horizontal plane.

Inasmuch as the vertical pattern of the antennas used has a vertical spread of some 15 degrees, it was impossible to determine definitely the optimum vertical angle. An accurate determination could be made only by an antenna which has a vertical spread of a very few degrees; but the fact that a definite optimum region was observed with an antenna the pattern of which was not confined to a very limited region in the vertical plane lends considerable emphasis to the conclusions. The results are quantitative only since none of the observers used calibrated equipment.

NOTES ON CONSTRUCTION AND ADJUSTMENT

In the course of the experimental work it was found that a mismatch of terminating impedance caused considerable back-end radiation and reception to ensue. One of the beauties of this antenna is the absence of back end radiation and reception. The authors derived no small amount of pleasure from contacting South African stations the west way around without interference from stations in the U.S.A.

The authors wish to bring once again to the attention of amateurs the fact that, except for most unusual conditions, signal propagation follows the great circle route.

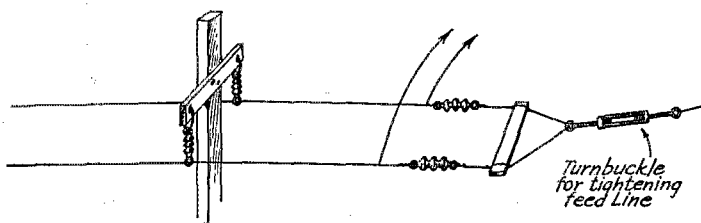

METHOD OF SUPPORTING FEED

Lines — The wires are run through the insulators and tightened at the ends of the line, the wire being allowed to slip freely through the insulators.

In laying out the great circle routes and determining the necessary spread of coverage in the horizontal plane to cover South Africa and Europe, a small geographical globe fitted with an encircling metal band, as shown by the photographic illustration, was found to be of inestimable value. The band is pivoted at two points, one

at the home location, and the other at its antipodes. Swinging the band through any given point on the globe automatically lays out the great circle course to the given point.

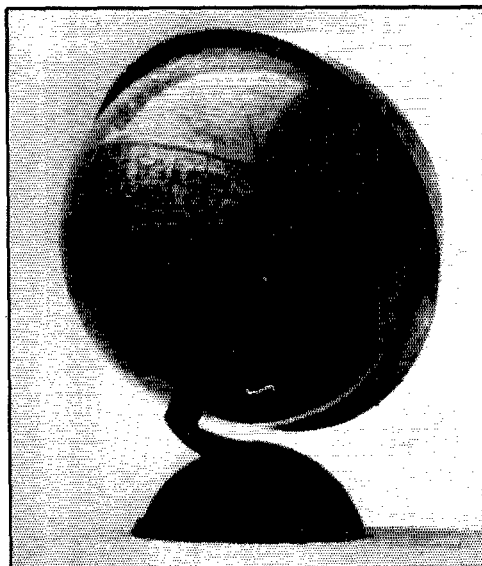

A SMALL GLOBE FITTED WITH A METAL BAND PIVOTED AT THE TRANSMITTING POINT IS HANDY FOR LOCATING GREAT-CIRCLE PATHS

In the sketch of Fig. 5 is shown the mechanical method of varying the angle of tilt of the antenna. The control rope may be run right into the operating room, if desired, or the winch may be mounted at the base of the mast. The authors used the manual method of control. Since the

vertical pattern of this particular antenna is quite broad, there is no necessity to make provision for a number of fine adjustments of the angle, and therefore there is no particular advantage in installing a motor driven winch. If a much larger antenna with a correspondingly narrower vertical pattern were constructed, then the motor driven winch with its continuously variable settings would be ideal. With the antenna used here

two or three settings were sufficient to insure adjusting the vertical pattern to the correct angle.

Another interesting fact worth noting was that the No. 12 hard-drawn copper wire used did not exhibit any signs of stretching after six months' use, and we think that this wire could be success-

(Continued on page 51)

Canada—U. S. A. Contact Contest

April 16—18, 1937

CQ VE—CQ W.

The amount of interest shown in the past VE/W contests has been a great source of encouragement to the committee of this year's contest. You will all remember the high Canadian score of 23,431 points, made by VE4QZ, and the high U. S. A. score of 15,120 made by WIBFT in last year's contest. All U. S. A. amateurs are extended a very cordial invitation to join with the VE boys in this fast stepping week-end contest. This will give many W's a chance to work all VE districts and it will also give the VE's a chance to grab off the last few States needed for W. A. S. The Canadian General Manager, Mr. Alex Reid, VE2BE, has heartily endorsed this contest, which is sponsored by the Queen City Amateur Radio Club of Toronto, with the following committee in charge: Mr. Gordon Coleman, Mr. George Cooper, VE3ACI, and Mr. Fred H. B. Saxon, VE3SG. Logs should be mailed to the chairman of the committee, Mr. Fred H. B. Saxon, 302 Lee Ave., Toronto, Ont., not later than midnight, April 30, 1937. Here are the simple rules:

Dates: Starts—Friday, April 16th, 6 p.m. local time.

Ends—Sunday, April 18th, midnight, local time.

Duration: 54 hours.

Frequencies: Any or all amateur bands may be used.

Object: Each VE will work as many W stations as possible, in as many United States A.R.R.L. sections (see list page 5, *QST*) as possible. Each W will work as many VE stations in as many VE sections as possible.

Scoring: The same log form as used for the Sweepstakes contest will be used. (See page 31, Nov. 1936 *QST*). Message preambles will be exchanged. Each preamble sent will count one point and each one received will count one point. It is not necessary for preambles to be exchanged *both* ways before a contact may count, but one must be sent or received before credit is claimed. All preambles must be handled under approved A.R.R.L. procedure. Mark each new section as worked. Standard message preambles will be used; the Check portion will consist of the RST report of the station worked. Sample preamble: NR 1 VE3QK CK 599 Windsor Ont 7:05 P Apr. 17. W stations multiply number of points by number of VE sections worked and multiply final score by nine (there being nine times as many U. S. A. sections). VE stations multiply number of points by number of U. S. A., A.R.R.L. sections worked.

Power and Operator Handicap: Each station using less than 50 watts input to the final stage may multiply the score by $1\frac{1}{2}$. If there is more than one operator at a station, the score of the highest operator will be the score for the station.

Prizes: A.R.R.L. certificates of merit will be awarded to the leader in each of the 69 A.R.R.L. sections in U. S. A. (and possessions) and Canada. In addition, member companies of the Radio Manufacturers Association in Canada are donating prizes for the highest scoring Canadian stations. Canadian Marconi Ltd. is donating a cup to be known as The Marconi Trophy. Canadian Westinghouse Ltd., Canadian General Electric Ltd., and R.A.C.-Victor Ltd. have made donations of splendid prizes and are hereby publicly thanked for their interest in amateur radio. The Contest Committee members will not be eligible for prizes, but may aid W stations in obtaining a higher score.

Strays

It seems we were a bit hasty in thinking that a good deal of the 50-cycle characteristic in W6 signals would disappear when Boulder Dam got into operation. W6DTY advises that only a small part of the LA area has been affected, most of it already having 60-cycle juice. It just goes to prove that you can't always believe what you read in the papers—we got the idea from an AP note telling about how all the clocks in LA were being rebuilt on account of the Boulder Dam power. Or was it just a publicity screed?

Oxweld No. 21 H.S. bronze rod can be threaded with a 6-32 die and with a nut and metal washer on each end makes an excellent way of binding *QST*, six issues at a time. A 9/64ths inch drill makes just the right size hole in the magazine. The holes should be three inches from top and bottom and a quarter-inch in from the bound edge. After the threaded rod has been slipped through the holes and the washers and nuts put on, any excess length of rod can be cut off with side cutters and the threads jimmied with a center punch.

—W4AAQ

What the League Is Doing

League Activities, Washington Notes, Board Actions—For Your Information

Executive Committee

The Executive Committee of the League held a routine meeting at headquarters on January 30th under the chairmanship of President Woodruff, with all the officers in attendance. Eight clubs were affiliated and three conventions approved. The Board meeting was called for May 7th. The administration of the Hiram Percy Maxim Memorial Award was accepted on behalf of the League. The Committee adopted recommendations to the directors for improvements in the regulations governing the eligibility of candidates for director and S.C.M. Several I.A.R.U. matters were passed upon. Walter Stiles, Jr., W8DPY, was named as the A.R.R.L. nominee for the C.B.S. Award for 1936. During the floods of March, 1936, Mr. Stiles transported emergency radio equipment, after tremendous hardships, a distance of more than fifty miles to Renovo, Pa., and gave a brilliant amateur performance in securing essential relief aid for that city when no other means of communication existed.

C.C.I.R. Plans

Messrs. John C. Stadler, VE2AP of Montreal, and James J. Lamb, QST's technical editor, representatives of the International Amateur Radio Union to the fourth meeting of the C.C.I.R. at Bucarest, are busy these days with their studies. The Union has submitted several technical contributions to the preparatory work, and in recent weeks the documents of the conference have been issued in considerable profusion. Mr. Stadler recently spent several days at West Hartford, going over plans at the headquarters. They sail from New York on May 4th, accompanying the U. S. delegation. En route Bucarest, they will visit in Berlin for a few days as the guests of the D.A.S.D., and upon returning they plan similar stops in London and other cities as may be possible, providing not only admirable amateur contact but an insight into recent technical work in those countries.

Financial Statement

The League had an excellent fourth quarter for 1936, concluding a very good year with gains in excess of the quite large appropriations made during that year by the Board of Directors. The business affairs of the League are running smoothly. (Members may be interested to know that the first printing of 40,000 copies of the current edition of the Handbook, weighing some 45 tons, were completely sold and shipped within three

months of their appearance; a second printing is now being distributed.) For the information of members, the fourth quarter's operating statement is here presented:

STATEMENT OF REVENUES AND EXPENSES EXCLUSIVE OF EXPENDITURES CHARGED TO APPROPRIATIONS, FOR THE THREE MONTHS ENDED DECEMBER 31, 1936

REVENUES	
Membership dues	\$16,815.04
Advertising sales, QST	23,938.55
Newsdealer sales, QST	12,001.77
Advertising sales, Handbook	6,050.08
Handbook sales	22,484.80
Booklet sales	2,867.61
Calculator sales	703.65
Membership supplies sales	3,754.12
Interest earned	454.85
Cash discounts received	245.80
Profit from sale of bonds	207.75
Bad debts recovered	89.03
	\$89,613.05
Deduct	
Returns and allowances	\$3,524.04
Increase in provision for newsdealer returns of QST	345.58
Collection and exchange	2.04
Cash discounts allowed	516.52
	4,388.18
Net revenues	\$85,224.87
EXPENSES	
Publication expenses, QST	\$16,554.58
Publication expenses, Handbook	18,528.47
Publication expenses, booklets	982.47
Publication expenses, calculators	382.68
Membership supplies expenses	2,118.55
Salaries	24,518.86
Postage	2,227.07
Office supplies and printing	2,843.38
Traveling expenses	1,521.04
QST forwarding expenses	916.19
Telephone and telegraph	739.27
General expenses	831.11
Insurance	51.20
Rent, light and heat	833.05
Provision for depreciation of furniture and equipment	330.78
General Counsel expenses	406.52
Communications Dept. field expenses	147.52
Bad debts charged off	238.58
Interest paid on bonds purchased	43.96
Headquarters Station expenses	35.41*
	74,179.87
Total Expenses	74,179.87
Net Gain before Expenditures against Appropriations	\$11,045.00
* Credit balance.	

At Bat

The League has defended amateur interests on a number of minor fronts in recent weeks. In Norfolk the F.C.C. recently held an investigation of amateur-b.c.l. relations,

where one of our members had been accused of b.c.l. QRM. A precedent being involved, General Counsel Segal, with Mr. Handy assisting, represented amateur interests. Several amateurs appealed for help on proposed anti-amateur municipal ordinances. Four W7 stations, operating in the Oregon A.R.R.L. Net when wires were out in a blizzard during the life of the F.C.C. limiting order on behalf of flood operation, were cited by district inspectors for violation of the order. Because they too were engaged in emergency communication, perfectly proper under the limiting order, the League has moved to have the citations quashed and their records cleared. In the Idaho legislature in February there was a bill making it unlawful to operate a radio set in an automobile on the public highways. Director Ralph Gibbons was on the job, aided with data from headquarters, and arranged for amateur representation at the hearing in the person of H. A. Sievers, W7BAR. Collaborating with R.M.A., the bill was killed. A bill to require state licenses at \$2 was introduced in the Connecticut legislature and will be promptly pounced upon by the League if it rears its ugly head in hearing.

F.C.C. Report

The Federal Communications Commission has published its second annual report to Congress, for the fiscal year ended June 30th last. The figures on amateur stations are those previously reported in *QST*, a total of 46,850, compared with 45,561 the year before, a gain of 1289 or 2.8%. During the fiscal year, 11,164 amateur applicants took the code test before examiners, 8687 passing, 22% failing. The written examination was administered to 11,850 candidates, 9190 passing, again 22% failing. This figure for failures is an average, dividing 21% for Class A, 23% for Class B, 22% for Class C, and 24% for abridged examinations under Rules 405-6.

An interesting paragraph, significant of the constant world-wide growth of radio, appears in the comments of the Telegraph Section on general allocation matters: "During the past year many new assignments were made to stations in all parts of the world, and the problem of finding adequate space in the needed portions of the spectrum for the United States was more difficult than at any time before. To show the tremendously rapid growth in the use of radio frequencies during the last few years, a comparison with the original international frequency list established by the Berne Bureau in December 1928 is illuminating. In the original list of December 1928 a total of approximately 1700 stations were listed. Five years later the number of stations was approximately 17,000 or a 10-fold increase. A rough check of the latest list dated March 1936 shows a total of 25,000 stations. These figures are for stations at fixed locations and do not include ship, aircraft, amateur, and portable stations."



DIXIE JONES' OWL JUICE

THE society for the prevention of cruelty to hams and other animals should oughto do something about the FCC chasing hams off of the air on account of because Windy Windom had a flood. They done it so cruel is what I am kickin' about. Bang, and they was off. Bang, and they was back on again. But in the interim between bangs there was sufferin' acute. Scores of hams, long and hopelessly addicted to 10-minute eqs without signing were suddenly and cruelly deprived of this solace. Their shaking fingers clutched wildly at keys they dared not use. They jibbered and foamed at the face and fell in a swoon but they kept off of the air. I never believed in that "cold turkey" treatment myself. I woulda tapered 'em off a little at a time if it hadda been me.

—W4IR of the "Dixie Squinch Owl."

Kansas State Convention

(Midwest Division)

Wichita, Kansas, April 17th-18th

ATTENTION GANG! The Wichita Amateur Radio Club has a responsibility this year in being the sponsors for the regular Kansas State Convention which will be held at the Hotel Lassen, Wichita, Kansas, on April 17th and 18th. A cordial invitation is extended to all A.R.R.L. members and radio amateurs in this state as well as all adjoining states. The program will be most interesting with unusual features such as a demonstration of two-way police radio by the Wichita Police Department, demonstration and lecture by a large airline radio engineer, NCR and AARS meetings, etc.

The committee has made it possible for those attending to enjoy themselves fully and the registration fee is ONLY \$1.98; it will cover two meals (one a swell banquet). The convention will open at noon on Saturday and will come to an end on Sunday at about 2:00 o'clock when the banquet is over and all prizes have been given away.

For further information write to Wilkie M. Miller, Secretary, 238 South Vassar St., Wichita, Kansas.

Iowa State Convention

(Midwest Division)

PLACE: Newton, Iowa.

DATE: April 9th and 10th.

HOTEL: Maytag Hotel.

Auspices of Y.M.C.A. Radio Club. Further information may be obtained from Robert Denniston, Y.M.C.A. Radio Club, Newton, Iowa.

A New I.F. Coupling System for Superhet Receivers

An Efficient Electro-Mechanical Filter Transformer of High Selectivity

By James J. Lamb*

IN RECENT years *QST* has chronicled a number of significant developments in i.f. coupling systems which have contributed to the constant improvement of our superhet receivers. The inevitable trend of these developments has been toward the ideal in adaptable selectivity; that is, toward selectivity that can be instantly and exactly fitted to the particular requirement of the type of signal and the receiving conditions of the moment. In amateur communication this means selectivity ranging from the 6-kc. order of bandwidth for 'phone to less than 100-cycle width for c.w. telegraph. In practice, modern high-selectivity tuned transformers in a two-stage i.f. system give us selectivity approximating the 6-kc. order, along with all the gain that can be used; and quartz crystal filters introduced into these i.f. systems obtain the c.w. extreme at the other end of the selectivity scale. Moreover, variable-selectivity transformer systems allow us to broaden the bandwidth in a range greater than the 6-kc. order; and the variable selectivity crystal filter gives us a controllable range of from less than 100 cycles up to a kilocycle or so of bandwidth at the higher extreme. But between these two lies an extremely useful mid-selectivity range which is not reached, on the one hand, with our current transformer-coupled systems at their sharpest; nor, on the other hand, with our present crystal filters at their broadest.

Practical utilization of this intermediate selectivity range is an accomplishment now made possible by a new type of electro-mechanical transformer-filter which is the culmination of several years of investigation by engineers of the Brush Development Company under the direction of Mr. A. L. Williams, to whom we are indebted for the opportunity of exploring the possibilities of the new device in its amateur applications and of first presentation of the information in *QST* as another contribution to the improvement of amateur communication. The new device is called a "Transfilter," since it combines the properties of a transformer

and electric-wave filter. Like the quartz crystal filter, it is electro-mechanical in nature. Also, like the quartz crystal filter, it involves piezo-electric action. But the Transfilter is not entirely a piezo-electric device and should not be considered as such.

FILTER ACTION

The quartz crystal filter usually comprises a balanced bridge circuit having a quartz plate in one arm. At frequencies outside of a narrow range around its resonant frequency, the quartz plate acts as a simple condenser and its capacity is balanced out in the bridge so that no signal is applied to the grid of the following tube. However, near resonance the impedance of the quartz plate suddenly drops to a low value and at a slightly higher frequency rises above normal. This change in impedance is confined to a very narrow range of frequencies and through this range of frequencies the bridge is no longer balanced. Thus the quartz plate, by unbalancing the bridge, permits a certain frequency to pass to the following amplifier tube in the radio receiver.

Many attempts have been made to use Rochelle salt crystal plates in oscillator and filter circuits to take advantage of their high piezo-electric activity. Such attempts have failed, however, because of the variation in resonant frequency of Rochelle salt plates as the temperature varies. Ordinary plates of Rochelle salt used in oscillator circuits are, in fact, less stable than relatively inefficient electrical tuned circuits. This instability is not effective in acoustical apparatus but would be very serious in crystals used as higher-frequency resonators. A change of 1/10 of 1% per degree in the natural period of a crystal that is used as a part of an acoustical device will have negligible effect on the operation of the whole device, but would amount to 500 cycles per degree were the crystal used alone at 500 kc.

In order to overcome the instability of resonant frequency in plain Rochelle salt plates, engineers of the Brush Development Company turned to the use of steel bars to determine the frequency of

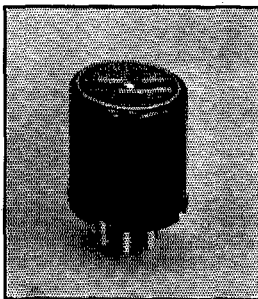

THE TRANSFILTER UNIT ENCLOSED IN A METAL SHELL FOR SHIELDING WITH AN OCTAL BASE FOR MOUNTING IN A STANDARD OCTAL TUBE SOCKET

* Technical Editor.

resonance and coupled the bars mechanically to extremely small plates of Rochelle salt. By using a large bar of steel and a very small piece of crystal, large variations in the characteristics of the crystal have negligible effect on the characteristics of the complete assembly. In the Transfilter, a steel rod somewhat less than $\frac{3}{4}$ -inch long and approximately $\frac{5}{16}$ -inch in diameter is used as the resonating element. Four small crystal plates $\frac{1}{8}$ -inch square and 0.02-inch thick are secured to this rod at its center. Two of these plates, connected in parallel, are used as driver or input elements and the other two as output elements. When an alternating potential of the proper frequency is applied to the plates, the bar is set into resonant vibrations which react on the crystal to generate a counter-electromotive force.

Qualitatively the Transfilter displays the same electrical characteristics found in quartz resonators; that is, essentially capacitive reactance at most frequencies with a sudden deviation from this reactance at the frequency of resonance of the bar. Hence it may be used in bridge circuits in the same manner as quartz. However, the Rochelle salt driven steel bar has somewhat higher mechanical damping with the result that the filter is not as sharp as quartz. This is advantageous in 'phone reception where the quartz filter causes too much attenuation of speech sidebands; yet the Transfilter provides much higher selectivity than is available with the usual electrical tuned circuits.

Apparently W. G. Cady¹ was the first investi-

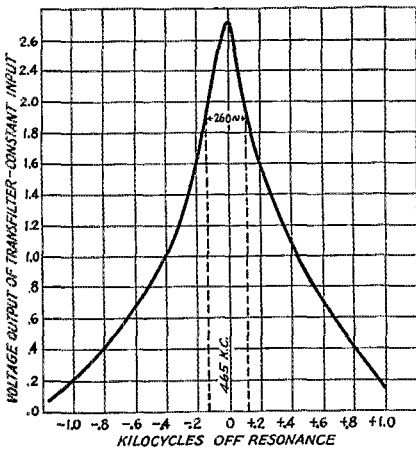

FIG. 2—RESONANCE CURVE OF A 465-KC. UNIT SHOWING THE Q TO BE APPROXIMATELY 1790

gator to use a steel bar, actuated by crystal plates, as a resonator. In his extensive work on

¹ W. G. Cady, "The Piezo-Electric Resonator," *Proc. I.R.E.*, p. 83, vol. 10 (April, 1922); also U. S. Patent No. 1,450,246.

quartz resonators he found it difficult to obtain quartz crystals large enough to operate at low frequencies. This led him to use long steel bars

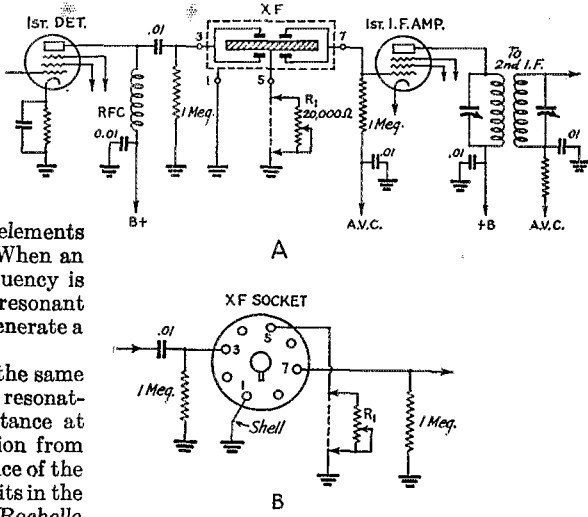

FIG. 1—CIRCUIT OF THE TRANSFILTER CONNECTED AS THE COUPLER BETWEEN THE FIRST DETECTOR AND FIRST I.F. AMPLIFIER OF A TYPICAL SUPERHET RECEIVER

An 80-mh. choke is used at RFC. The common terminal is connected to ground for the maximum selectivity shown by the curve of Fig. 3. Variable selectivity over a broader range may be obtained by insertion of the variable resistor R_1 . A variety of other circuit adaptations are possible, as suggested in the text. Base connections, as viewed from the bottom, are shown below.

acted by quartz crystal plates and provided efficient resonators for frequencies down into the audible range.

The Brush engineers, on the other hand, developed the use of steel bars to obtain stable high-frequency operation from a piezo-electric material whose elastic properties varied appreciably with temperature, years of laboratory work resulting in a crystal-actuated steel bar capable of working at radio frequencies. A technique has been developed which makes possible the reduction in size of crystal plates to the point where their characteristics have negligible effect on even very small steel bars. In the Type A Transfilter, for instance, the frequency drift is approximately 100 cycles per million per degree Centigrade.

To eliminate the necessity for a carefully balanced bridge circuit, four crystal plates are provided in the Transfilter. As indicated schematically in Fig. 1, two opposite plates connected in parallel are connected to one input terminal and the other two plates are connected to one output terminal. When a voltage of the right frequency is impressed on the input plates (from the plate circuit of the mixer tube), the steel bar is set in vibration and such vibration actuates the output crystals (which feed the grid of the following

tube). At other frequencies the bar will not vibrate and so the output crystal plates cannot deliver voltage at these frequencies to the output terminals.

The fundamental period of the units used in the Type A Transfilter is about 155 kc. and,

FIG. 3—SELECTIVITY CURVE OF A TRANSFILTER UNIT IN THE CIRCUIT OF FIG. 1 WITH THE COMMON CONNECTED DIRECTLY TO GROUND

The bandwidth is approximately 600 cycles at twice resonance input and approximately 2 kc. at 10 times resonance input.

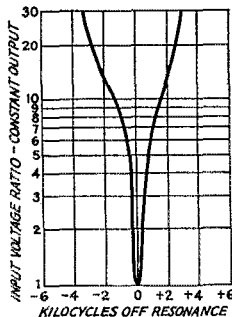

while they may be used at this frequency, they are primarily designed for use at the third harmonic, 465 kc. A great deal of work has been done to design the units so that they are remarkably free of parasitic resonances, most of them being "clean" within 15 kilocycles on either side of the 465-kc. point.

Each Transfilter is mounted in a special fiber shell. This shell is then placed in a metal housing fitted with a standard octal base and the case filled with wax. Thus they are independent of humidity variations. Temperatures ordinarily encountered in receivers will not impair the operation of the Transfilter, although excessively high temperature (above 130 degrees F.) would damage the small crystal plates. Placement of the unit below the chassis or apart from the hotter power circuit components will insure adequate safety.

The Transfilter unit has four terminals: shell, input, output and common. When the Transfilter is used in a bridge circuit, the common and either the input or output terminal are used and the circuit is the same as for quartz filters. When used as a coupler, as diagrammed in Fig. 1, the input terminals connect, through a condenser, to the plate of the mixer tube. The output terminal goes directly to the grid of the first i.f. stage and the common terminal is grounded. When the Transfilter feeds directly into the grid of a tube, a grid leak in the order of $\frac{1}{2}$ megohm or an r.f. choke must be used in the grid circuit. The selectivity curve of Fig. 3 is for a Transfilter used as the coupler between a 6K7 and the grid of the following tube in the circuit of Fig. 1.

By inserting tuned circuits or impedance matching networks between the Transfilter and input and output tubes, it is possible to modify the shape of the resonant curve considerably and thus to control selectivity. Selectivity also may be varied by a variable resistance between the common terminal and ground, as shown by the alternative connection of R_1 in Fig. 1.

More than one filter element can be used in a circuit to obtain band-pass action and a great deal of work is now being done in the hope that such units may one day be made available.

George L. Bidwell

DR. GEORGE L. BIDWELL, former director of the A.R.R.L., passed on at his home in Washington, D. C., on February 19th as the result of a sudden stroke. A host of friends, both in and out of amateur radio, are saddened by his loss.

He was elected to the A.R.R.L. Board in December of 1923, during the period when all the members of the Board were directors-at-large. In May of 1924, when special elections were held to choose directors for the first time as the representatives of divisions, Doc. became the first director from the Atlantic Division. He was succeeded at the beginning of 1926 by Dr. Woodruff, now our president.

He was a chemist by profession, holding a responsible position in the Department of Agriculture. A very able man, possessed of funds of information and splendid judgment, he accomplished much important work in his profession. Because of his unusual qualities, his office in recent years had become virtually a council chamber, where much of his time was taken by persons seeking the benefit of his judgment on matters in his field.

The same thing was true of his radio associations. He had not been an active amateur for many years; he did not deal in radio technique. His contribution to amateur radio was good judgment, and his active kindly interest and sound advice were an important part of the lives of those who knew him well. He was for years one of the stalwarts of the Washington Radio Club and had the call 3HW. As a chemist, he gave amateur radio its first real understanding of the workings of the chemical rectifiers of bygone days, and we believe was the first to propose the ammonium sulphate rectifier. He had an early interest in railway emergency work by amateurs and was chairman of the Committee on Railroad Emergency Service, which led to the important QRR work of later years.

He was born at Goffstown, N. H., August 31, 1880. Graduating from Tufts College in 1905 with a degree in chemistry, he spent his first year with the B. F. Sturtevant Co. at Hyde Park, N. Y., followed by a couple of years as instructor in chemistry at Rhode Island College. He joined the Department of Agriculture late in 1907, advancing through various positions until, at the time of his death, he was the chemist in charge of the cereal section of their Food & Drug Administration.

Particularly at Washington and West Hartford, but at many other places as well, the untimely passing of Doc. Bidwell will be mourned.

A Practical Survey of Pentode and Beam Tube Crystal Oscillators for Fundamental and Second Harmonic Output

Operating Characteristics and Performance with RK23-25, 802, RK39, 807, 6L6 and 6L6G Tubes

By James J. Lamb*

THE primary function of the crystal-controlled oscillator in a transmitter is to keep the emitted wave constant in frequency. The amount of power the oscillator can provide is the secondary consideration. Of course everyone knows that—or at least has known it at some time or other. But the present trend seems to be putting the cart before the horse. We have become more prone to judge crystal oscillators solely on their ability to generate gross watts, with little regard to their ability to stay “put” in frequency. Not that considerable power cannot be obtained along with good frequency stability. The right kind of tube in a suitable circuit with proper operating voltages and loading certainly will permit it. But a lot of current notions concerning crystal oscillators just do not reconcile these requirements. In this article we shall attempt to survey the various crystal oscillator circuits used in our transmitters with medium-power tubes of the popular pentode and beam types.

TUNED-PLATE OSCILLATORS

To get at the factors which influence the frequency generated by a crystal oscillator, it will be a good idea to go through some circuit fundamentals and get a fresh picture of what's involved. The elemental circuit which serves as the basis of most of the crystal-controlled oscillators we use to-day is actually a tuned-grid tuned-plate

circuit, the crystal being connected between the grid and cathode, and a condenser and coil in parallel being connected between the plate and cathode, as diagrammed in Fig. 1A. To distinguish it as a general type, let us call it “tuned-plate crystal-grid,” or “T.P.X.G.” Oscillation occurs when the plate tuned circuit is adjusted for resonance at a frequency *higher* than the frequency of the crystal; that is, when the plate circuit reactance is inductive. Oscillation stops when the plate circuit is tuned to resonance with the crystal frequency or to a lower frequency. The feedback from plate to grid circuit is through the grid-plate capacitance of the tube (C_{gp}). The frequency of oscillation is, of course, that for which the reactance of the complete circuit is zero. This will be very nearly the anti-resonant (parallel resonance) frequency of the crystal.

Since the frequency of oscillation must be that for which the reactance of the complete circuit is zero, if anything happens to change the reactance of some one element in the network, then the frequency must shift to a new value to keep the total reactance zero. The shift will be relatively small, of course, because the reactance characteristic of the crystal itself is so steep, compared to that of coil-condenser combinations. A shift of only a part or so in ten thousand may occur with a relatively large change in circuit reactance. But that might well be a kilocycle or more at amateur-band frequencies.

The worst effect of this kind is the frequency

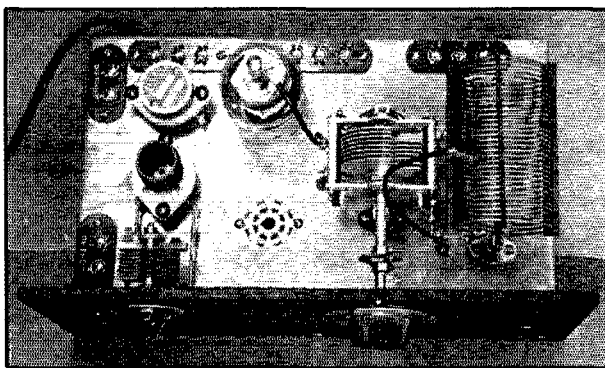

THE UNIT USED IN TESTING THE PERFORMANCE OF THE 6 TYPES OF 15-WATT CLASS PENTODE AND BEAM TUBES AS CRYSTAL OSCILLATORS IN VARIOUS CIRCUITS

The crystal and cathode circuit elements are at the left, octal and “standard” base tube sockets in the center, and plate tank at the right. The circuit is given in Fig. 2.

*Technical Editor, *QST*.

shift with tuning of the plate circuit or variation in the load. It is here that the type of tube gets into the picture. Invisible in the schematic diagram but nevertheless painfully present in the actual circuit is the *effective* grid-cathode capacitance of the tube, shunted across the crystal and hence affecting the crystal's oscillation frequency.

This capacitance is not the simple C_{gf} given in the tube characteristic tables. It is greater than that—with some tubes it may be many times greater. Moreover, it is not constant, but varies with plate load impedance. The magnitude of this capacitance is a function of the tube's grid-plate capacitance and the amplification. Therefore, it is highest and varies most with tubes of high amplification factor and appreciable grid-plate capacitance. The run of receiving-type high- μ triodes are such tubes—and to demonstrate this, monitor the frequency variation that occurs with a triode crystal oscillator like a 6A6 or 53 as its plate load impedance is varied by tuning or load coupling. Even lower- μ tubes like 56's and 6C5's are none too satisfactory in this respect. Remember this in case you happen to plan operation near the edge of a band with a high- μ triode oscillator.

The variation in frequency with variation in plate and filament supply voltage is also of importance. This actually ties in with plate-impedance variation as just outlined and is most noticeable with high- μ triodes of appreciable grid-plate capacitance.

Well, where does that leave us? In the T.P.X.G. circuit we want to use a tube of high amplification factor so that the crystal need not work so hard; but we can't have the frequency stability, which we also want, with the usual high- μ triode. "Which Tube for the Crystal Oscillator?" George Grammer asked that question and answered it in an article of that title in Feb., 1932, *QST*. The answer was, "a pentode"—which meant a 47 at that time. The answer is still a pentode or tetrode, although the number of types from which we may choose has increased

considerably since the question was first asked. For the lower-power oscillator, the audio receiving-type pentode has the desired high-gain characteristic, necessitating less drive from the crystal. At the same time it has small grid-plate capacitance relative to that of comparable triodes, but this capacitance is still sufficient to provide

adequate feedback coupling at the usual crystal frequencies. Tuned-plate oscillators using such pentodes have been practically standard for several years and need no extolling. Their relatively good frequency stability with variations in circuit reactance and loading is well known. Frequency change with variations in supply voltage are further minimized by the compensating action on plate impedance which results when screen and plate voltage vary proportionately, an inherent property of pentode and tetrode circuits which triodes cannot provide.

In any oscillator circuit, the crystal's amplitude of vibration, and hence its temperature and consequent frequency "creep," is affected by the crystal-frequency excitation voltage. Excessive excitation can make the crystal vibrate so vigorously as to shatter itself. In the tuned-plate crystal-grid type of circuit, this excitation, with a given tube, will vary generally with the r.f. voltage developed across the tuned plate circuit. The higher the r.f. voltage between plate and cathode, across $L_p C_p$, the greater the feedback through C_{gp} to the crystal. This voltage is maximum when there is no load coupled and the plate tank is tuned near the minimum plate current point. Therefore, the drive on the crystal is likely to be greatest when the crystal oscillator is running idle. When the output circuit is loaded, its impedance is reduced, the excitation falls off and the strain on the crystal is lessened. In fact, loading may reduce the r.f. voltage across $L_p C_p$ to the point where there is insufficient feedback to keep the circuit oscillating—as we are well aware from experience. Thus we must make several compromises in arriving at

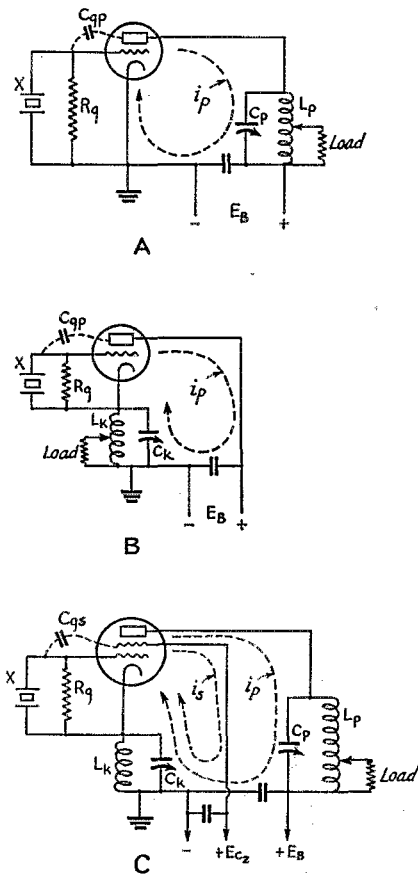

FIG. 1—ELEMENTARY TUNED-PLATE CRYSTAL-GRID AND TRI-TET CIRCUITS SHOWING THE RETURN PATHS FOR PLATE AND SCREEN R.F. CURRENTS i_p AND i_s .

The circuits of A and B are identical in operation although they differ in appearance.

safe and stable operating conditions with this type of circuit. The loading must be no greater than will permit reliable starting of oscillation. The plate tuning should be far enough on the inductive side of resonance (tuning capacitance reduced) so that excessive crystal excitation will not occur under no-load conditions, and so that a small incidental shift in load reactance will not bring the plate circuit into the critical region near resonance where oscillation stops. The circuit is not likely to operate reliably at the tuning adjustment for maximum output and efficiency.

These generalities apply to

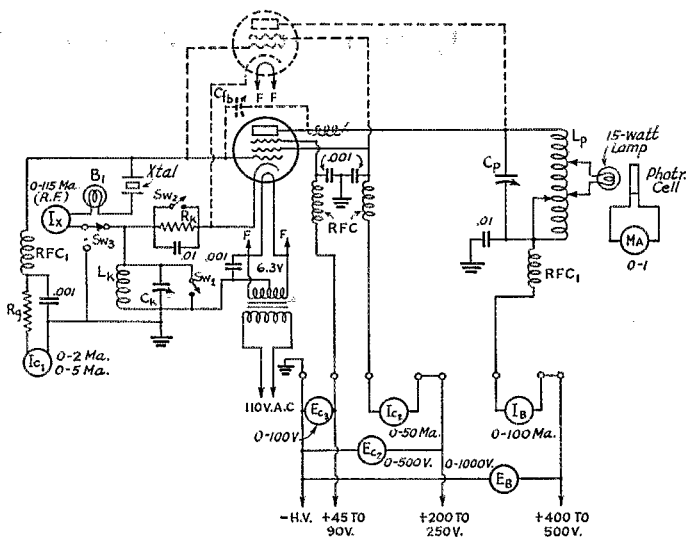

FIG. 2.—THE CIRCUIT OF THE TEST UNIT IS ADAPTABLE TO EACH TYPE OF TUBE AND CIRCUIT LISTED IN THE TABLE OF OPERATING DATA, ALTERNATIVE CONNECTIONS FOR PENTODE AND TETRODE (BEAM) TYPES BEING SHOWN IN THE DIAGRAM

- L_k —Cathode coil for Tri-tet operation. 3.7- μ h. coil: 15 turns of No. 18 enameled spaced to 1-inch length on 1-inch diameter form (10.5 turns, 1-inch length on 1.5-inch diameter form).
- 6- μ h. coil: 12 turns No. 18 enameled spaced to occupy $\frac{3}{4}$ -inch length on 1.5-inch diameter form.
- 2.5-mh. choke for grid-plate oscillator of Fig. 10.

- L_p —Plate tank coil, 24- μ h. maximum inductance with shorting clip for lower values; 30 turns No. 14 bare copper, $\frac{3}{8}$ -inch length, 8 turns per inch, 2.5-inch diameter, air-wound.
- C_k —Cathode condenser (Tri-tet excitation control).
- C_p —150- μ fd. plate tuning condenser (Cardwell MR-150-BS).
- C_f —External feedback coupling capacitor for T.P.X.G.

- operation with RK23-25 and 802 tubes; 30- μ fd. mica trimmer type (National M30), coupled to plate by 3 turns of insulated wire around plate lead.
- RFC₁—2.5-mh. 125-ma. r.f. chokes (National Type R-100).
- R_k—400-ohm 2-watt cathode-bias resistor.
- SW₁—End rotor plate of C_k bent to short at maximum capacitance.
- SW₂, SW₃—Jumpers.

the tuned-plate type oscillator whether the plate tank circuit is connected between the plate and "ground" as shown in Fig. 1A, or between the cathode and ground as shown in Fig. 1B. The important thing is that the tank is between the

plate and cathode; the location of the "ground" point is inconsequential so far as the operating characteristics are concerned.

THE TRI-TET CIRCUIT

The Tri-tet circuit with grid-cathode crystal connection is also a member of the T.P.X.G. family, but its operation is considerably different from that of the simple tuned-plate crystal oscillator, particularly with regard to the variation of excitation and frequency with loading or plate-tank tuning. In this circuit a tetrode or pentode tube is used with the excitation-controlling tank circuit $L_k C_k$ connected between cathode and ground, and the tuned load circuit connected between plate and ground, as shown in Fig. 1C. Disregarding the plate for the moment, it is evident that the r.f. return circuit to cathode for the screen grid, as well as for the suppressor grid in a pentode, is through $L_k C_k$.

The screen-control grid capacitance provides feedback coupling. Hence, with $L_k C_k$ inductively reactive the

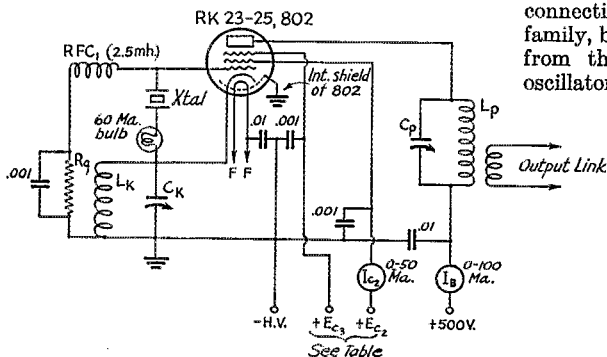

FIG. 3.—RECOMMENDED TRI-TET CIRCUIT FOR RK23-25 AND 802 TUBES FOR FUNDAMENTAL AND DOUBLING OPERATION

Grid leak bias is used. Plate coil L_p tunes the fundamental or second harmonic and is approximately 14- μ h. inductance (19 turns, 2.5-inch diameter, 8 turns per inch). Other components are as specified in the Table and described in Fig. 2.

circuit oscillates with the screen grid (or screen and positive suppressor) as the anode. The plate return circuit is also through $L_k C_k$, as well as through $L_p C_p$. Hence, there will be some additional feedback voltage contributed by the plate

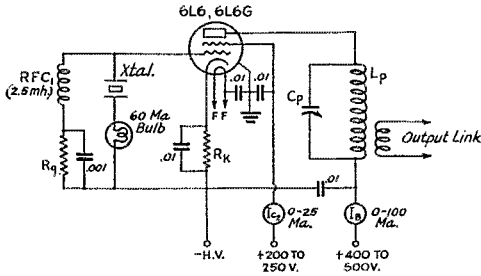

FIG. 4—THE RECOMMENDED T.P.X.G. ("PEN-TODE") CIRCUIT FOR 6L6 AND 6L6G BEAM TUBES
 L_p is the same as in Fig. 3 ($14 \mu h.$) and is tuned for fundamental output only. These tubes should always be operated with combination cathode-resistor and grid-leak bias. See the Table for typical circuit values.

circuit r.f. current flowing through $L_k C_k$. But this additional feedback will be minimum and practically negligible with the plate tank $L_p C_p$ tuned to resonance and unloaded. Under these conditions, the parallel impedance of $L_p C_p$ is maximum and therefore the plate-return r.f. current is minimum. The tuned plate tank acts as a rejector, like a wave-trap. When the plate tank is loaded or detuned, its impedance is decreased and the r.f. current flow back to the cathode through $L_k C_k$ increases. The r.f. voltage across $L_k C_k$ rises and so does the crystal-frequency excitation in the grid circuit.

Thus the Tri-tet circuit, using a well-screened tube and delivering output on its fundamental frequency, behaves in just the opposite fashion to a tuned-plate type oscillator. The drive on the crystal is least under no-load conditions and its excitation increases with loading. This variation is in the right direction, of course, since it removes the danger of damaging the crystal in case of loss of load and automatically provides increasing excitation to meet the requirements of increased loading. It also avoids stoppage of oscillation in case of inadvertent overload. Moreover, the crystal circuit oscillates continuously regardless of loading or tuning adjustments of the plate circuit, so long as $L_k C_k$ is of the proper inductive reactance; that is, $L_k C_k$ tuned in the broad optimum range considerably higher than the fundamental oscillation frequency. The plate tank $L_p C_p$ can be, and should be, resonated "on the nose" for maximum output, rather than tuned somewhat to the low-capacitance side as is necessary with the simple tuned-plate type oscillator. As would be expected, variation in frequency with variation in plate tuning or load-

ing is much less with the Tri-tet as compared to the tuned-plate oscillator under equivalent conditions.

While there is considerable tolerance in the inductance and capacitance values of the cathode coil L_k and condenser C_k in the Tri-tet circuit, the optimum values are not the same for all tubes. The feedback requirements appear to be affected by the screen-grid characteristics of the tube (screen-grid transconductance), and this may vary even in tubes of the same general type but of different manufacture. The optimum L_k values for the current transmitting type pentodes certainly are not the same as the cathode coil figures given several years ago for Type 59 tubes, when that type was adopted as the sole expedient for transmitter use—for the simple reason that there wasn't anything else. In the present state of tube development the 59 has been thoroughly superseded by the newer and more suitable tubes.

In general, the cathode coil inductance should be much less than what would be considered a good value for a plate coil to tune to the crystal frequency. For instance, a cathode coil of 3.7 microhenrys has been found optimum for 3.5-Mc. band crystals with some of the 6 types of tubes investigated, while a 6-microhenry coil works better with others. But the plate coil inductance for the 3.5-Mc. band may range from 14 to 24 microhenrys—more than 6 times the cathode coil inductance in some instances. Furthermore, the cathode circuit tuning capacitance C_k should not be too large. In no case should it be large enough to permit tuning L_k to the crystal frequency. Over-excitation not only causes frequency creeping as the result of heating and endangers the crystal, but also reduces the output. The typical

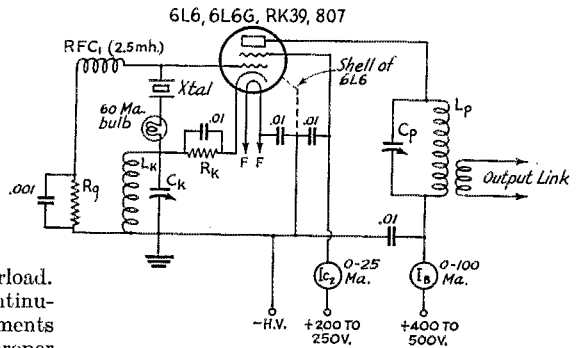

FIG. 5—TRI-TET CIRCUIT RECOMMENDED FOR BEAM TUBES
 A $14\text{-}\mu h.$ plate coil is used for both fundamental and second-harmonic output. The 6L6G is recommended only for doubling.

values given for the various tubes in the Table have been found satisfactory and are recommended for the tubes listed.

Appreciable grid-plate capacitance will affect

the feedback action, of course, since the circuit may try to operate simultaneously as a Tri-tet in the manner just described and as a simple tuned-plate oscillator. With a plate tuning adjustment such that the two feedback voltages are in phase, this will be evidenced by a sharp rise in crystal excitation; while with a slightly different adjustment, such that the two feedback voltages are out of phase, the excitation will drop suddenly and may become insufficient to maintain oscillation, especially with the oscillator unloaded. This occurs only with tubes of relatively poor internal screening, however, and has not been found seriously objectionable with any of the tubes tested except the 6L6G.

In addition to avoidance of tuning $L_k C_k$ near to fundamental resonance, there is one other adjustment which reduces output, both on the fundamental and second harmonic, and should be avoided. This is resonance of the cathode circuit at the second harmonic. It occurs, for instance, when C_k is at about half capacitance (50 μf d. plus circuit capacitance) with the 3.7- μh . cathode coil and a 3.9-Mc. crystal, and is readily recognized by the dip in output which occurs when the cathode tuning is varied through this region. The cathode tuning should be on either side of this point, either near maximum or minimum of C_p , depending on which setting gives the desired output with the lesser crystal excitation.

The grid-cathode Tri-tet oscillator is also an excellent harmonic generator, second harmonic output comparable to that obtained on the fundamental occurring with optimum circuit conditions. Plate efficiencies of the order of 40 to 50

RK 25 PENTODE OSC $E_B = 450\text{V.}$

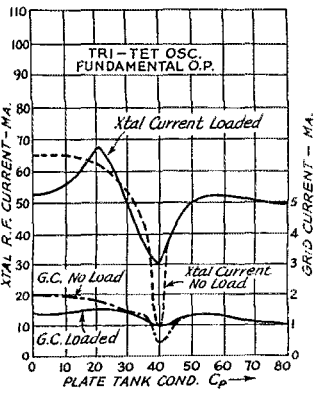
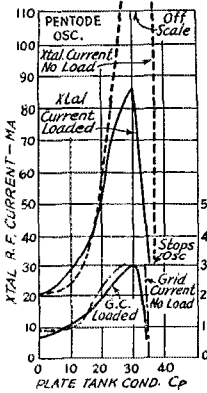
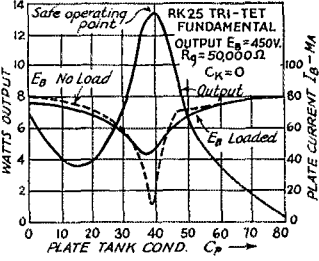
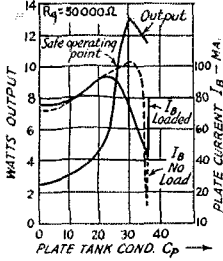

FIG. 6—TYPICAL PERFORMANCE CURVES FOR THE RK25 PENTODE IN A T.P.X.G. CIRCUIT WITH ETHERNAL FEEDBACK (LEFT) AND IN A TRI-TET CIRCUIT (RIGHT)

The plate circuit is low-C (24- μh . coil) for fundamental output. Only grid leak bias was used. Note the much lower order of crystal current with the Tri-tet circuit.

percent, compared to approximately 65 percent on the fundamental, are usual with good 3.5-Mc. band crystals. In the recommended Tri-tet circuits diagrammed, it is intended that the

TYPICAL OPERATING DATA FOR CIRCUITS WITH 3.5-MC. BAND CRYSTALS

Type Tube	Circuit (Fig. No.)	Output Freq.	L_k $\mu\text{h.}$	C_k $\mu\text{f.}$	R_g Ohms	R_k Ohms	C_p $\mu\text{f.}$	E_b Volts	I_b Ma.	E_{c2} Volts	I_{c2} Ma.	E_{c3} Volts	I_x Ma.	I_c Md.	Output Watts	Approx. Plate Eff.
RK25	T.P.X.G.	Fund.			Not Recommended—See Text											
RK25	Tri-Tet (3)	Fund.	3.7	0	50,000	—	100	500	45	200	25	+45	25	0.9	15	65%
RK25	Tri-Tet (3)	Doub.	3.7	100	50,000	—	25	500	55	200	30	+45	60	2.4	13.5	50%
802	T.P.X.G.	Fund.			Not Recommended—See Text											
802	Tri-Tet (3)	Fund.	6	100	20,000	—	100	500	55	230	20	+90	55	4.5	16	60%
802	Tri-Tet (3)	Doub.	6	100	20,000	—	25	500	65	230	20	+90	60	4.8	15	45%
807	T.P.X.G. (4)	Fund.			Not Recommended—See Text											
807	Tri-Tet (5,10)	Fund.	6	100	50,000	400	100	500	47	250	7	—	45	1.8	15	65%
807	Tri-Tet (5)	Doub.	6	100	50,000	400	25	500	53	250	7	—	40	1.8	13	50%
RK39	T.P.X.G. (4)	Fund.			Not Recommended—See Text											
RK39	Tri-Tet (5,10)	Fund.	6	100	30,000	400	100	500	48	250	5	—	50	2.6	15.5	65%
RK39	Tri-Tet (5)	Doub.	6	100	30,000	400	25	500	60	250	5	—	50	2.4	13	45%
6L6	T.P.X.G. (4)	Fund.	—	—	100,000	400	100*	500	45*	250	7	—	10	0.2	15*	65%*
6L6	Tri-Tet (5,10)	Fund.	3.7	100	100,000	400	100	500	45	250	7	—	35	0.75	15	65%
6L6	Tri-Tet (5)	Doub.	3.7	100	100,000	400	25	500	55	250	7	—	50	0.9	14	50%
6L6G	T.P.X.G. (4)	Fund.	—	—	100,000	400	100*	500	45*	250	10	—	35	0.6	13*	60%*
6L6G	Tri-Tet (5)	Fund.			Not Recommended—See Text											
6L6G	Tri-Tet (5)	Doub.	3.7	100	100,000	400	25	500	50	250	7	—	62	1.0	13	50%

* These values are with critical adjustment for maximum output. Output and efficiency must be reduced with lower setting of C_p for safe operation.

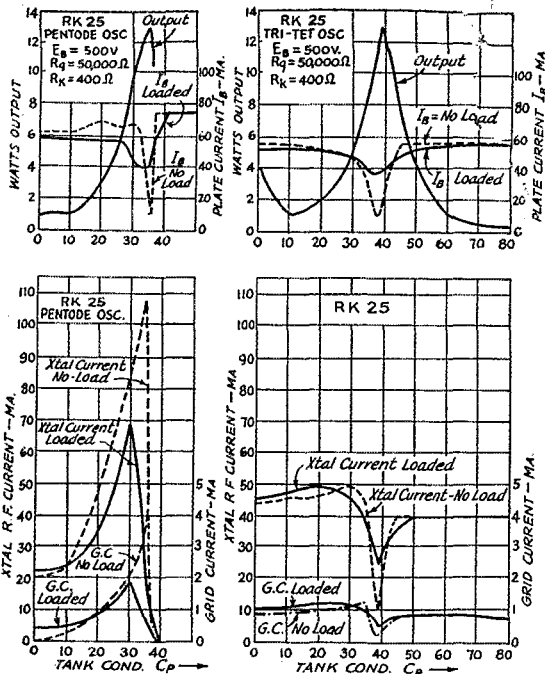

FIG. 7—PERFORMANCE CURVES WITH THE RK25 USING COMBINATION CATHODE-RESISTOR AND GRID LEAK BIAS

No-load crystal current is greatly reduced by the cathode-bias addition with the T.P.X.G. circuit, although Tri-tet operation is little changed.

same plate coil be used for both fundamental and second-harmonic output, the shift from one to the other being made simply by tuning the plate condenser C_p . This gives low-C output conditions on the second harmonic (C_p of 25 μf . or so at 7 Mc.) and fairly high-C conditions on the fundamental (100 μf . or so at 3.5 Mc.). Since a fairly low-impedance tank has been found to give more favorable fundamental output conditions with the tubes tested (especially the beam types), this is a desirable arrangement both in convenience and performance.

The curves of Figs. 6, 7 and 8 show representative performance data taken with an RK25 pentode in both T.P.X.G. ("pentode") and Tri-tet circuits using 3.5-Mc. band crystals. Uniform results were obtained with each of a group of factory-mounted crystals of the "standard" amateur grade made by different manufacturers. A few "bargain" crystals also tried did not run so uniform, although all oscillated in the Tri-tet circuit. Lessened output, or higher crystal excitation requirement for the same output, occurred with some which were unreliable in the tuned-plate circuit. In the tests with these and the other tubes, optimum operating voltages, circuit values and loading were determined for approximately 15-watt fundamental power output, with proper consideration for the screen and plate dissipa-

tion ratings of the respective tubes and safe r.f. current of the crystals (100 ma. maximum).

In the case of the RK25 T.P.X.G. tests, the feedback capacitance was critically adjusted to the minimum value which would allow 15-watt output with optimum load coupling and plate tuning.

Plate voltage of 450 volts was used for the grid-leak bias curves of Fig. 6. This was increased to 500 volts for the tests with combined cathode-resistor and leak bias (Fig. 7) in order to compensate approximately for the voltage drop in the cathode resistor. Power output was measured with a lamp and Weston Photronic Cell previously calibrated at 60 cycles.

D.c. grid current, crystal r.f. current, plate current and power output, for both optimum load and no-load conditions, are plotted against plate tank condenser scale readings — which represent percentage of the 150- μf . maximum capacitance of C_p .

It must be understood that r.f. crystal current is not directly an indication of crystal excitation. The amplitude of vibration of the crystal, which is what affects its temperature, is a function of the oscillation frequency voltage applied to the crystal. While

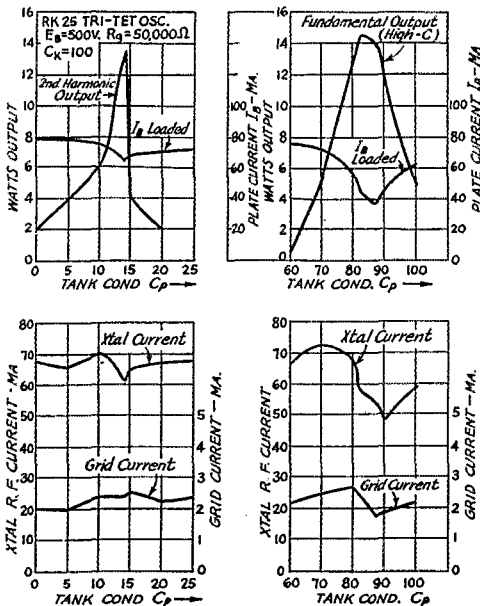

FIG. 8—COMPARATIVE FUNDAMENTAL AND SECOND-HARMONIC OUTPUT PERFORMANCE CURVES FOR THE RK25 TRI-TET OSCILLATOR

Circuit conditions were the same except that C_p was varied to tune the 14- μh . plate coil to either frequency. The 7-Mc. output with low-C tuning is practically the same as the fundamental 3.5-Mc. output with high-C tuning.

the oscillation frequency current through the crystal will depend on this voltage, it will not be exactly proportional to it unless the current and voltage always have the same phase relationship, although the matter of phase may be considered inconsequential for approximate checking purposes. But there may be current of other frequencies, especially harmonics of the crystal oscillation frequency, which will be indicated by a current-squared galvanometer or lamp but which do not play any part in exciting the crystal. For these components the quartz crystal is simply a dielectric of extremely low loss. Their contribution to crystal heating is entirely negligible unless the crystal should happen to have a corresponding oscillation frequency, which is unlikely. In consequence, especially with the Tri-tet oscillator operating as a harmonic generator, a considerable portion of the indicated crystal r.f. current will be unrelated to crystal heating. The indication errs on the side of conservatism, however, since the reading will be higher than the actual value of crystal-frequency current. The d.c. grid current indication probably comes closer to being representative of the crystal-frequency r.f. voltage, since the rectified grid current follows the excitation voltage developed across the crystal. It is interesting to note that the curves of grid current and r.f. crystal current do not always vary similarly. Tests show that grid current in the Tri-tet oscillator varies smoothly with variation of C_k , increasing as the cathode capacitance is tuned from minimum to maximum, while the r.f. crystal current rises to a maximum as the cathode tank tuning passes through second-harmonic resonance, and then falls off. The current increase is not accompanied by a corresponding increase in excitation voltage. As previously described, this is the point at which there is a decided dip in both fundamental and second harmonic output in the plate circuit.

The curves, with their captions, are self-explanatory and hardly require detailed discussion. They tell their own story in confirmation of the previous discussion of operating characteristics of

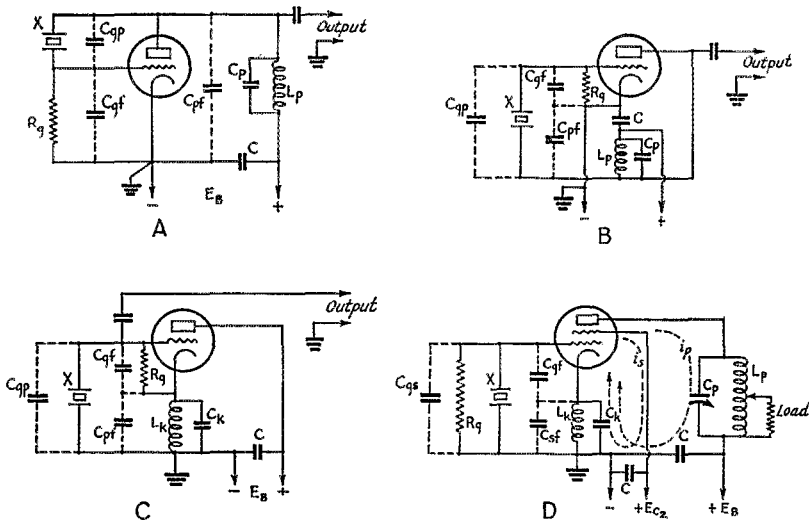

FIG. 9—OSCILLATOR CIRCUITS WITH GRID-PLATE CRYSTAL CONNECTION

A, B and C are identical in operation although differing in appearance.

these crystal circuits. Tests on the other tubes gave similar results, using the circuit constants specified for the respective types in the Table—except for the minor digressions peculiar to beam-type tubes which have been previously described.

One other effect most likely with the beam-type tubes (6L6, 6L6G, 807 and RK39) is a tendency for apparently strong parasitic oscillation,

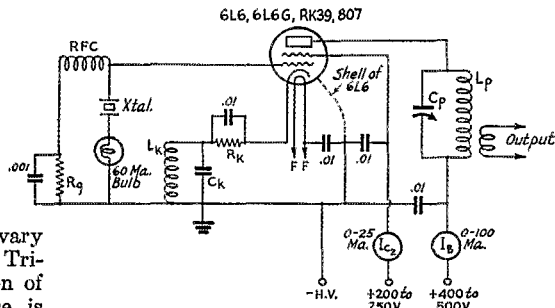

FIG. 10—GRID-PLATE CRYSTAL OSCILLATOR CIRCUIT RECOMMENDED FOR FUNDAMENTAL OUTPUT WITH BEAM-TYPE TUBES

L_k is a 2.5-mh. r.f. choke. Other circuit constants are as specified in Fig. 5.

tion, as indicated by high r.f. crystal current, with the plate tank tuned lower than crystal frequency. This is more marked with these tubes in a simple tuned-plate oscillator circuit than in the Tri-tet circuit, but occurs with both. Since it is not generally an oscillation of crystal frequency, but is a parasitic phenomenon resulting

from the high mutual of these tubes, it does not excite the crystal and is likely to cause damage only to the tube. The crystal simply acts as the low-loss quartz dielectric of a condenser furnishing a capacitive path for the parasitic current in the grid circuit.

OSCILLATORS WITH GRID-PLATE CRYSTAL CONNECTION

In addition to the tuned-plate crystal-grid type of oscillator, another basic circuit is that in which the crystal is connected between the grid and plate instead of between the grid and cathode. An elementary form of this circuit is shown in Fig. 9A and, rearranged for explanation of the principles of operation, in Fig. 9B. This is essentially a Colpitts circuit (or Ultra-Audion, if you prefer) in which the crystal constitutes the grid-plate tuned circuit shunted by the tube's grid-plate capacitance and across which the grid-filament and plate-filament capacitances C_{gf} and C_{pf} in series form the essential capacitive r.f. voltage divider. With high-frequency crystals, the plate feed impedance L_p is usually a radio-frequency choke by-passed by C_p , although a resistor is sometimes used as the plate feed impedance with low-frequency crystals. Reactance of the plate-filament circuit must be *capacitive* for oscillation to occur and $L_p C_p$ accordingly must be resonant at a frequency *lower* than the oscillation frequency of the crystal. The circuit of Fig. 9C is the same as the circuit of A and B except that the plate inductance (choke) has been shifted to the cathode side of the plate-cathode circuit and the plate brought to ground r.f. potential by the large by-pass condenser C . The crystal, shown connected directly between grid and ground, is actually still connected between grid and plate, since the plate is also grounded for r.f.

In practice this type of oscillator is not capable of supplying any considerable power output for transmitter use, even though the $L_p C_p$ combination is tuned. When the attempt is made to adjust the plate (or cathode) circuit close enough to resonance to obtain appreciable power, the circuit stops oscillating. For this reason, the grid-plate crystal oscillator in its elementary form is used mostly with low-frequency crystals as a frequency calibration source from which negligible power is taken.

In order to adapt this type of oscillator for use as a power generator at amateur-band frequencies, several modified circuits are used. One version, employing a triode-connected tube, has a parallel-tuned circuit connected between plate and plus B (ground) in addition to the capacitive cathode circuit, as shown by John L. Reinartz on page 24, October 1936 *QST*. This plate circuit is resonated to the oscillation frequency and coupled to the load. Another form, employing the Tri-tet idea, is shown in Fig. 9D. This circuit also

is the favorite of W1QP's and has been described by him at a number of amateur conventions. Like the Tri-tet with the grid-cathode crystal connection, it operates as a combination triode oscillator and tetrode or pentode amplifier, the screen-grid acting as the triode oscillator anode and its r.f. return current, i_s , being supplemented by the plate r.f. return current, i_p . It works best with tubes of high mutual conductance, such as the beam types; excitation depends on the r.f. voltage developed across C_{gf} portion of the capacitive divider, and since the voltage across this portion of the circuit tends to become smaller as the shunting capacitance C_{gp} becomes larger with thinner crystals, tubes other than those of the easy-to-drive type oscillate feebly or not at all at the higher frequencies. Even at 3500 kc., for instance, RK23-25 and 802 pentodes may refuse to re-start oscillating under conditions which do not impair the operation of the same set-up arranged as a grid-cathode crystal Tri-tet. The beam types, in the circuit of Fig. 10, oscillate vigorously at this frequency, however. With these tubes the fundamental output, screen and plate input, efficiency and r.f. crystal current are of the same order as given for Tri-tet operation in the table, although the second-harmonic output is considerably less than that obtainable with the same types as grid-cathode Tri-tet oscillators.

With the same crystal, the generated frequency is slightly higher with this type of circuit as compared to the frequency generated with the grid-cathode crystal connection (20 to 30 parts per million, or about 100 cycles higher with a 3.5-Mc. band crystal).

In summary, the practical operating suggestions for 15-watt class pentode- and beam-type oscillators, supplementary to these given in the Table, are as follows:

1. With the well-screened transmitting pentodes (RK23-25 and 802), the Tri-tet circuit is recommended for both fundamental and second-harmonic output with 3.5-Mc. band crystals.
2. The transmitting-type beam tubes, 807 and RK39, have insufficient grid-plate capacitance for dependable T.P.X.G. operation at 3.5 Mc. without external feedback and are best adapted to use in the circuits of Figs. 5 and 10.
3. The 6L6 and 6L6G receiving-type pentodes are satisfactory in 3.5-Mc. T.P.X.G. oscillators without external feedback and the 6L6 type can be used in the Tri-tet with fundamental output.
4. The metal shell of the 6L6 tube always should be grounded to avoid excessive feedback and general instability.
5. The RK23-25 and 802 pentodes may be operated in Tri-tet oscillators with grid-leak bias alone or with combined cathode-resistor and leak bias.
6. The 807, RK39, 6L6 and 6L6G beam tubes

(Continued on page 106)

A Push-Pull Amplifier for the Band-Switching Exciter

A 500-Watt Unit Using 100TH Tubes

By George Grammer*

LAST month we described an exciter, capable of delivering an output of the order of 75 watts, which while giving the convenience of band-switching over three bands, also attained the flexibility necessary for working on more than three by the use of tapped plug-in coils.¹ The present article is concerned with a higher-power push-pull amplifier which was built as a companion piece for the exciter.

A little explanation of objections is desirable as well as customary. These two units are part of a complete c.w.-'phone transmitter in which, as is generally the case, the input to the final stage was dictated by power supply and audio considerations. As things stand at present, an audio output of about 250 watts can be obtained at fairly low plate voltages and with relatively inexpensive tubes, but doubling the audio power (and with it the carrier power) runs the cost up at a rate far from commensurate with the almost negligible improvement in strength. But audio power is not the only factor which makes a 500-watt input 'phone transmitter about the best balance between signal and cost for the fellow who wants fairly high power. Such things as r.f. tubes, plate voltages, and r.f. components, particularly tank condensers, also must be considered. That 3 db added on in going from 500 watts to a kilowatt is pretty expensive.

For 500 watts plate input, a push-pull r.f. stage consisting of two 100-watt (plate dissipation) tubes, will easily do the job. At efficiencies readily

obtained in practice, the tubes will be running at less than rated dissipation without modulation, leaving a little to spare for the added losses during modulation. These added losses are rarely considered by amateur builders of 'phone transmitters—perhaps with some justice, considering the nature of speech and the comparatively small time during which peak conditions are reached in a properly-operated transmitter—but then it really does no harm to the tubes to let them run along easily. If this be heresy, make the most of it—and buy tubes oftener.

From the economic standpoint, there is a good deal to be gained by using low plate voltage on a modulated stage.

Power supply cost usually is somewhat less, but the real difficulty with high plate voltages is that of obtaining suitable tank condensers. Especially is this the case in transmitters designed to work over a wide frequency range, such as that between 3.5 and 30 megacycles. Split-stator condensers having sufficient plate spacing can be obtained in capacity ratings suitable enough for the 14- and 28-Mc. bands, but are not available for 3.5 Mc. at the prices amateurs want—or can afford—to pay. Even when ob-

tainable, such condensers are far too large to fit well in the ordinary construction job. Yet a certain minimum $C-L$ ratio in the tank circuit is absolutely necessary if the stage is to modulate linearly.

Let's digress here a moment to discuss this $L-C$ ratio business a bit further. There have grown up a few superstitions about $L-C$ ratios which need to be examined in the light of common sense. A certain amount of flywheel effect is

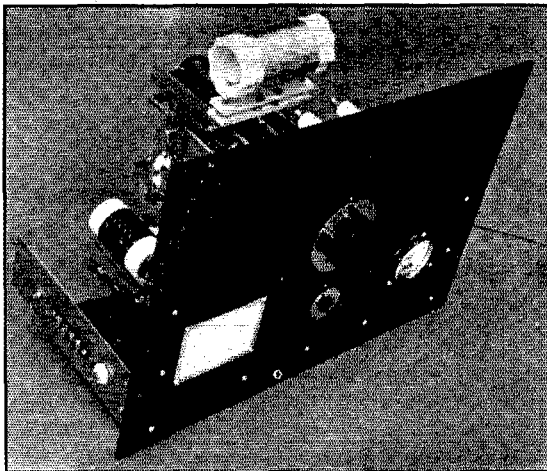

INTENDED FOR CONSERVATIVE OPERATION AT 500 WATTS INPUT ON 'PHONE, THIS AMPLIFIER USING PUSH-PULL 100TH'S CAN BE PUSHED TO CONSIDERABLY HIGHER POWER IF NEEDED

The small dial below the plate tuning dial controls the grid circuit condenser, a non-critical adjustment.

* Assistant Technical Editor.

¹ "A 75-Watt Output Transmitter or Exciter Combining Band-Switching and Plug-in Coils," *QST*, March, 1937.

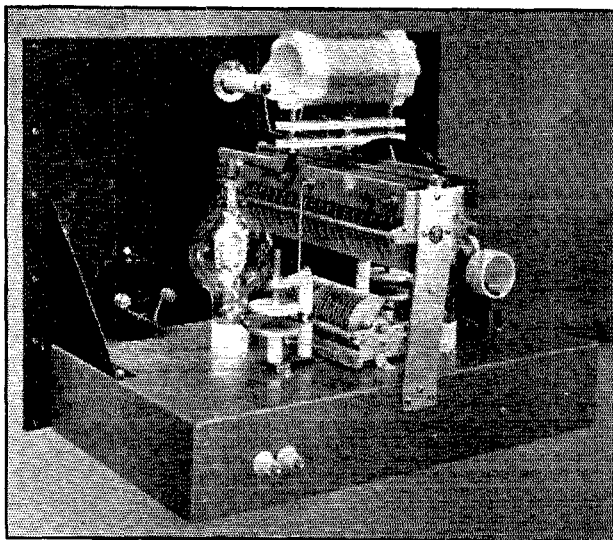

THIS VIEW FROM THE REAR SHOWS THE LAYOUT OF TUBES AND COMPONENTS

The tubes and neutralizing condensers are interchanged on opposite sides of the tuning condensers to give symmetrical wiring and short neutralizing leads.

needed in the tank circuit to give a straight-modulation characteristic, and this in turn requires a certain amount of tank capacity. As John Reinartz pointed out in March *QST*,² engineers have come to regard a minimum tank circuit Q of 12 as essential for linear modulation and satisfactory reduction of harmonics. Meeting this requirement does not unduly reduce the "efficiency" of the amplifier—the quotes are used because it is questionable whether there is any appreciable reduction at all when efficiency is defined as *fundamental* output divided by plate input. An unreasonably high $L-C$ ratio simply increases the harmonic output without adding much if anything to the fundamental output. There is no difference at all from the tube's standpoint. When the tube is loaded to a given plate current it is working into the same effective load resistance whether the tank is low- or high- C . With reasonable C in the circuit, the tank losses may be a bit higher (especially under no-load conditions, when the circulating current is highest) but the overall efficiency is not greatly reduced.

To take a specific example, assume a 500-watt input amplifier having a tube efficiency of 70% and transfer efficiency of 90%, neglecting the distribution of power between fundamental and

² Reinartz, "How Much C ?", *QST*, March, 1937.

harmonics. The output to the antenna is $500 \times 0.7 \times 0.9$, or 315 watts. Should a larger $C-L$ ratio cause the transfer efficiency to drop to 80%, the output would be $500 \times 0.7 \times 0.8$, or 280 watts. The difference is only 35 watts in 300-odd, and at that the figures are unfavorable because higher tube and transfer efficiencies are readily obtainable; 75% for the tube and 90% for the tank circuit, with a circuit of sufficient Q , being quite usual in practice. The *Handbook* points out that when a fixed input is considered, always the case when 'phone is in question, efficiency is not of great importance because reasonable difference—10% or so—makes no perceptible difference in the signal strength. Which is not to be taken as condoning poor construction or poor design—any legitimate means of reducing losses naturally is to be encouraged, but we do not consider reducing losses at the expense of other more desirable attributes as exactly legitimate. In this connection, it should be mentioned that no-load plate current means very little as a measure of amplifier efficiency—a very small no-load plate current figure simply means that under no-load conditions a very high r.f. voltage is developed across the tank circuit. Other things being equal, this indicates high tank impedance *unloaded*. How-

ever, no power amplifier works usefully without a load, and the conditions change very rapidly as the load is increased. Tank current drops, and so do tank losses.

But to get back to the practical amplifier: The

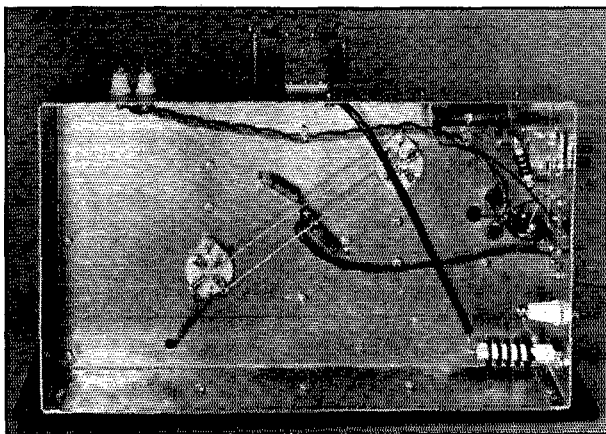

A BOTTOM VIEW OF THE CHASSIS

Few components and none particularly critical as to placement.

fact that it was intended for operation in the 28-Mc. band as well as the three below it in frequency made desirable, if not necessary, the use of tubes designed for service at the very high frequencies. At the same time, the requirement that the 500 watts input should be obtained at relatively low plate voltage also made it necessary to use tubes which would drive well at low voltages. The 100TH tubes looked like a good prospect on both points, and have proved so in practice.

Conventional plug-in coils are used in the amplifier. Although changing coils for different bands undoubtedly is a nuisance, both electrical and mechanical considerations dictated the use of the time-tried system. The problems in band-switching a push-pull stage have been set forth in one of our Problem Contests, and need but little amplification here. In this particular case, the space requirement was a prime consideration, since the other equipment to go with the r.f. units could only be compressed so far and still fit on a rack which would stand upright in an ordinary room. Hence it was necessary to keep the panel space down as much as possible. After looking at the thing from all angles, it was considered more desirable to get the electrical efficiency and design freedom characteristic of plug-in coils, at a slight sacrifice in convenience. Besides, most of the drudgery of changing bands was already eliminated by band-switching in the exciter.

The circuit diagram of the amplifier is given in Fig. 1. It is the ordinary push-pull circuit using split-stator condensers and link-coupled input except for one point—bypass condenser C_3 from the center-tap of the grid coil to ground. This condenser was found to be necessary when one of the commonest forms of parasitic oscillation in push-pull amplifiers—a low-frequency oscillation caused by resonance in grid and plate r.f. choke circuits—developed. An alternative method for avoiding such oscillation would be to use a low-inductance grid choke, such as a solenoid about a half inch in diameter with a hundred or so returns. The bypass condenser, by grounding the center of the grid coil, puts two grounds on the grid circuit—the other being the rotor of the grid condenser—but careful observation has shown no ill effect from its use when the grid coils are accurately center-tapped.

The layout of the amplifier is such as to keep all leads symmetrical. Reversing the order of tubes and neutralizing condensers on either side of the tank condensers makes short neutralizing leads possible and also avoids the necessity for crossing these leads. The grid and plate coils are mounted at right angles to each other to reduce magnetic coupling between them. The layout seems to be quite effective, since the amplifier neutralizes easily and is completely free from any tendency toward ultra-high-frequency parasitics. This last probably results from the fact that,

while the amplifier is perfectly symmetrical to ground and all corresponding leads are identical, the grid and plate connections differ considerably in length. This is also true of the leads in the neutralizing circuit.

The chassis measures 17 by 10 by 3 inches, and is made of Electralloy. The panel, of Lamtex, is

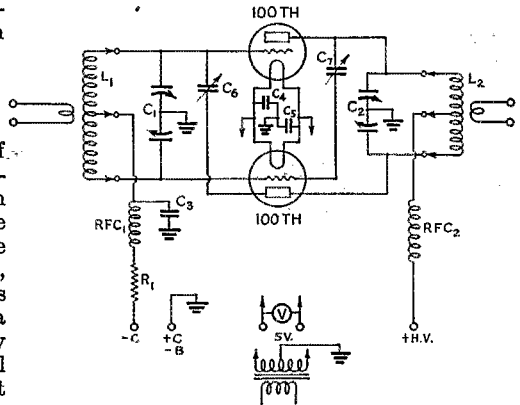

FIG. 1—CIRCUIT DIAGRAM OF THE AMPLIFIER

- C_1 —Split-stator transmitting condenser, 100 μ fd. per section (Cardwell MR-100-BD).
- C_2 —Split-stator transmitting condenser, 75 μ fd. per section, 0.2-inch plate spacing (Cardwell XC-75-XD).
- C_3 —250- μ fd. mica condenser, 500-volt.
- C_4, C_5 —0.01- μ fd. paper.
- C_6, C_7 —Neutralizing condensers (National NC-800).
- R_1 —2500 ohms, 25 watts.
- RFC₁—Receiving-type choke (National R-100).
- RFC₂—Transmitting choke (National R-154U).
- L_1 —3.5 Mc.: 3.5 turns No. 18 enamelled, close-wound; link 3 turns.
7 Mc.: 30 turns No. 14 enamelled, close-wound; link 2 turns.
14 Mc.: 12 turns No. 14 enamelled, length 1 $\frac{3}{8}$ inches; link 2 turns.
28 Mc.: 6 turns No. 14 enamelled, length 1 $\frac{3}{8}$ inches; link 2 turns.
- L_2 —3.5 Mc.: 28 turns No. 12, diameter 4 inches, length 4 $\frac{3}{4}$ inches.
7 Mc.: 22 turns No. 12, diameter 2 $\frac{1}{2}$ inches, length 3 $\frac{3}{8}$ inches.
14 Mc.: 8 turns No. 12, diameter 2 $\frac{1}{2}$ inches, length 1 $\frac{1}{2}$ inches.
28 Mc.: 6 turns $\frac{1}{4}$ inch copper tubing, diameter 2 $\frac{1}{2}$ inches, length 4 inches.
- 3.5-Mc. coil wound on National XR-12A form; 7- and 14-Mc. coils on National XR-10A forms. 28-Mc. coil self-supporting.
- V—A.c. voltmeter, 0-10 volts.

10 by 10 $\frac{3}{4}$ inches, $\frac{1}{4}$ inch thick, and is fastened to the chassis by Bud 5-inch panel-mounting brackets, with further support furnished by bolts through panel and the front end of the chassis. The dimensions are standard for relay racks.

The plate tank condenser is supported partly by the panel and partly by a heavy aluminum strip fastened to the chassis at the back. The strip also serves as a ground strap for the condenser, and because of its width has very little inductance and presumably low resistance. The jack-base for the plate coils (National Type XB15) is mounted cross-wise on the condenser by

means of angle brackets made of half-inch brass strip bent for the purpose. These brackets also form the connections between the condenser starters and the ends of the tank coils. The grid condenser is fastened directly to the chassis. The layout is simple enough, and can readily be followed in the photographs.

There is very little apparatus underneath the chassis; the few parts there can be seen clearly in the bottom-view photograph. The grid-circuit bypass condenser, C_3 , is mounted to give a fairly short connection between the center-tap of the grid coil and ground; the chokes, both grid and plate, can be mounted in any convenient location. The connection between plate choke and the center-tap of the plate coil is made through high-voltage wire. With the exception of the high-voltage lead, which goes through the chassis by way of a porcelain feed-through insulator, the power leads all go to a connection strip. A jack in the grid lead permits measurement of grid current.

The grid coils are wound on National XR13 forms with the associated plugs and base. Winding data are given with the diagram. The link coils are wound to fit inside the forms rather than on the outside of the windings, since there is more room inside and the leads can be brought out inconspicuously.

Plate coil construction differs with the frequency. The 7- and 14-Mc. coils are wound on the ordinary six-inch ceramic forms; the 3.5-Mc. coil is on a large form of the same type, while the 28-Mc. coil is self-supporting copper tubing. All are mounted on National PB15 plug bases with the exception of the 3.5-Mc. coil, which is too large to fit on this type of base. A special base was made from quarter-inch bakelite for this coil.

Little need be said about the method of neutralizing and tuning of the amplifier, since these have been treated at length in other articles describing push-pull amplifiers and in the *Handbook*. A neutralizing indicator such as an r.f. galvanometer or flashlight and loop is to be preferred to a neon lamp, since touching the latter to a hot part of the circuit often disturbs the balance to ground sufficiently to give false indications. The amplifier should neutralize completely, provided there is no stray coupling between the driver and amplifier plate tanks. The possibility of such coupling should not be overlooked, especially if the two units are mounted in a rack one above the other. It can be detected by checking for r.f. at the amplifier plate tank with the driver running, but disconnected from the amplifier grid-circuit link. As a final test of neutralization, plate voltage should be applied with the grid bias such that 40 or 50 milliamperes of plate current flow. If swinging the grid condenser through resonance with the plate circuit does not cause oscillations to start, the neutralization can be considered satisfactory. This test should be tried on

all bands. Parasitic oscillations, if present, also will show up under these conditions.

The driver described last month gives considerably more than enough excitation for the final on the 14-, 7- and 3.5-Mc. bands so that it is necessary to retard the excitation control to limit the grid current to the rated maximum value. The amplifier grid leak, R_1 , is a compromise value which, at the rated grid current of 90 ma. for the two tubes, gives sufficient bias for good plate efficiency. In conjunction with fixed bias of about 50 volts, the actual bias under operating conditions is considerably higher than double cut-off. The tubes seem to work best at about rated grid current regardless of the bias; going higher in grid current does not give much improvement in output or efficiency, and going lower usually causes the output to drop and the tube plates to show more color.

The operating plate voltage for modulated service is 1700 volts, approximately. For 500 watts input, this plate voltage calls for a plate current of about 300 milliamperes. The tubes easily can be loaded to this current. For c.w. work, higher plate voltages readily could be used, since the tank condenser plate spacing is great enough. At the highest plate voltage available from the power supply—about 2250 volts—the condenser does not arc over even under no-load conditions, when the r.f. plate voltage is highest. At the lower operating plate voltage, the tube plates show practically no color with keying, and are considerably below the rated dissipation in continuous operation.

On 28 Mc., where the RK20 in the driver is operating as a doubler, less excitation is available, naturally, but the driving power is still sufficient to run the amplifier Class-C under the specified conditions.

No antenna-tuning apparatus is incorporated in the amplifier proper, since it is often desirable to change the coupling system with different antennas or as new ideas come forth. The five-plug coil bases provide two plugs for output connections; link coils or direct taps can be used for output coupling. Although the diagram shows a link, at the present time the coils are tapped to work into a pi-section filter.

Strays

Amateurs interested in making observations on band conditions with particular reference to DX work are invited to communicate with Mr. J. F. Diepstraten, PAØLB, Loopschansstratt 74, Breda, Netherlands. Records of observations of this type are being kept by a group of Dutch amateurs, and supplementary information from amateurs in other countries will be welcome. The information so gathered may be of value in predicting future DX conditions.

How Would You Do It?

Announcing the Prize Winners in the Second and the Problem for the Fourth in the Series of Practical Problem Contests

THERE is still plenty of room for advance in the electro-mechanical departments of ham radio. Circuit design is coming along very nicely, thank you, but the business of building the circuit into a practical piece of gear still involves one problem after another. If evidence of this fact were required it could be found right here in the "solutions" offered for the second in the series of problem contests.

The problem (remember?) was to find a means of switching the push-pull final amplifier of the transmitter to any of three bands without introducing undue losses and without a whole slew of expensive switches. Some provision had to be made for coupling to the grid tank and from the plate tank.

The suggested schemes ranged all the way from a plan for entirely separate tank and coupling circuits, switched, to the use of variometers plus variable condensers to cover the entire frequency range continuously. Most of the methods were practical in the sense that they *could* be made to work but, we must admit, none of them were genuinely hot notions. In short, the problem of band-switching is still a very live one.

Anyway, first prize this month goes to Benson B. Boss, Jr., W3DAZ, for a scheme having as its basis a home-brew drum switch which serves to short out center sections of the coil while simultaneously switching the tap position of the coupling leads. It is the sort of idea that manufacturers might think about. Maybe we could do with some such drum switch as a purchasable item.

Second prize goes to Charles H. Gierman, W3FCQ, for his suggestion of a turret-type coil changing gadget similar to that already used in some receiving gear. It is bulky, fairly difficult to build, but eminently practical.

Here are the winning papers:

Band-Switching

By Benson B. Boss, W3DAZ *

WITH an expenditure of around a dollar in cash and some hours of time, a simple but effective and efficient method of 3-band switching for a push-pull final may be built by anyone moderately handy with tools.

Refer to the diagram for the basic idea of the system; the details will need some explanation.

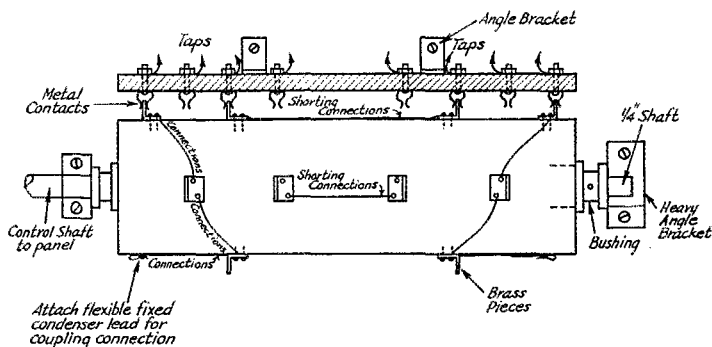
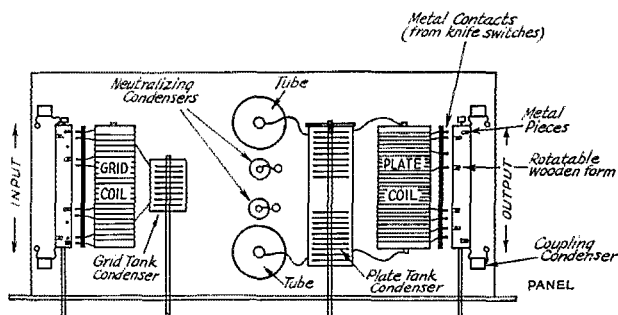

FIG. 1—THE DETAILS OF THE DRUM SWITCH AND CIRCUIT ARRANGEMENT SUBMITTED BY W3DAZ

The switching forms are made of wood, approximately $1\frac{1}{2}$ inches in diameter and as long as the coils—highly satisfactory forms are those made by sawing ends off of ten cent store rolling pins. Two of such forms will be needed: one for the grid circuit, and one for the plate circuit. They are exactly the same in both cases.

* 4415 Norwood Road, Guilford, Baltimore, Md.

The coils should be designed to operate on the lowest desired frequency without any cutting out of turns. The grid coil may be air-wound, and the plate coil either air-wound or made of copper tubing.

First procure a victron, mycalex or bakelite strip as long as the coil, and on it mount eight heavy brass knife switch contacts with their openings vertical. These contacts should be mounted opposite the approximate places on the coil from which the taps are to be taken; the exact positions must be found by trial and error. Then firmly mount this strip as high as the middle of the coil—a good mounting being made by the use of two heavy angle brackets.

On the ends of the wooden form, and in its exact center, mount $\frac{1}{4}$ -inch shaft bushings by means of wood screws. (Just the right kind of bushings, with holes ready for mounting, may be obtained from "Erector-Sets.") In these bushings put metal rods which are to serve as the shaft for the rotating wooden form; the "front" rod being long enough to project through the panel to act as the control shaft. On the form, in straight rows, 90° apart, mount by two screws, right angle pieces of 1/16-inch copper $\frac{1}{2}$ -inch by $1\frac{1}{4}$ -inch, bent $\frac{3}{4}$ inches from the "top." These right angles, of course, must correspond to the switch contacts into which they are to fit upon rotation. Slight adjustments may be made by bending the metal pieces after they have been mounted. Wire up the contacts as indicated in the diagram, bringing the coupling connections to Fahnestock clips or binding posts near the ends of the form. Mount the form parallel to the strip by putting the shaft through $\frac{1}{4}$ -inch holes drilled in two $\frac{1}{8}$ -inch pieces of metal that are firmly fastened to the baseboard. The middle of the form must be just as high as the contacts on the bakelite strip, and the metal pieces on the form should project into these contacts about $\frac{1}{2}$ inch. If the holes are correctly drilled and the brackets mounted right up against the bushings, there will be no play as the form is turned.

The last operation to be performed is to connect, by bus wire, the contacts on the strip to correctly placed taps on the coils. The taps must be determined experimentally, by deep technical knowledge, or by darned good guessing.

Band-Switching Amplifier

By Charles H. Gierman, W3FCQ¹

INSTEAD of messing around with half a dozen switches and all the wiring that goes with them why not adapt the turret-type coil changing described in September, 1935, *QST* to band-switching in the transmitter?

The advantages of this system are many.

¹ R. D. 2, Hightstown, N. J.

There are no shorted sections of coils to introduce losses. There is no danger of disturbing neutralization of the tubes. The transmission lines may be link-coupled or tapped on to the grid and plate coils at the center where they belong. There is some construction work, but it is fairly simple and few tools are needed. While the system does

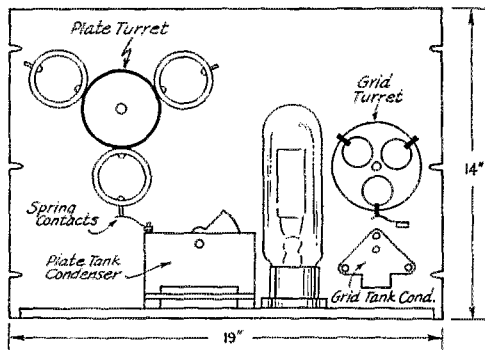

FIG. 2—THE LAYOUT FOR A TURRET-TYPE COIL CHANGING SYSTEM FOR THE FINAL AMPLIFIER OFFERED BY W3FCQ

require two extra coils for each circuit, the cost of these is offset by the elimination of several expensive r.f. switches.

The one thing that might be called a disadvantage in the system is that it does take up more room than switches would. However, the outfit will fit in a relay rack, and most of us can spare the additional 6 or 7 inches of height that the coil assembly needs. Fig. 2 is a sketch showing the amplifier mounted on a standard relay rack panel.

The coil assembly uses standard $2\frac{1}{2}$ -inch diameter transmitting coil forms, mounted on $3\frac{1}{2}$ -inch diameter disks which may be wood or bakelite. The shaft is a $\frac{1}{4}$ -inch brass or bakelite rod, though probably a piece of $\frac{1}{4}$ -inch wooden dowel could be used to good advantage. Simple bearings are mounted on the panel and at the near end of the assembly. Hardwood will make bearings that will give good service.

The contact points are mounted on strips of bakelite or mycalex. Most layouts will require five contact points—two for the ends of the coil, one for the center-tap, and two for the transmission line. The contacts suggested are the General Radio 138-CD or 138-PD Detent Switch Contacts which will center the coil in position if suitable "bumps" are made in the contact blades. The contact blades are spring bronze which could be silver plated for looks and efficiency. The insulating strip holding the contact blades could be mounted directly on the frame of the tuning condenser, making the layout more compact.

The alternative method is to use disks about 8 inches in diameter with the strips of contact points mounted directly to the disks and the self-

supporting coils mounted inside the assembly.

Either of these construction methods are suitable for the plate circuit. For the grid circuit something more compact would simplify construc-

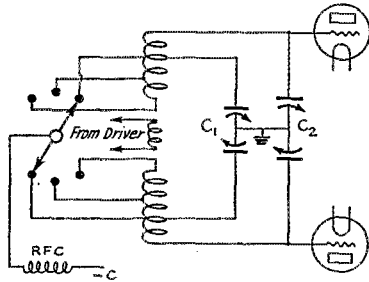

FIG. 3—SHOWING THE CONNECTION OF AN EXTRA TANK CONDENSER TO HELP OUT IN MAINTAINING A CONSTANT LC RATIO
The idea is from W1JZU.

tion. The layout originally referred to (described in September 1935, *QST*) would probably fill the bill. The turret coil assembly manufactured by Communications Products, Inc., would also fit in very well.

In the accompanying sketch no dimensions are given because these would depend to a great extent on the size and type of coil forms, condensers, and tubes used in the construction of the amplifier.

— . . . —

A couple of interesting ideas from the pile are shown in Figs. 3 and 4. The first, suggested by W1JZU, shows a method of using a second tank condenser, C_1 , across part of the coil in the manner of a band-spread condenser. In the highest-frequency position this condenser is out of the circuit, while in the lowest-frequency position it is

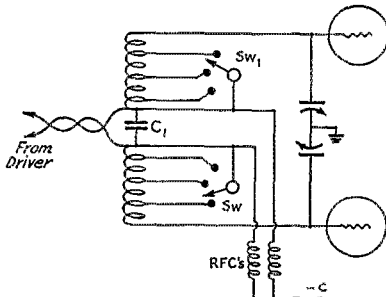

FIG. 4—ONE WAY OF COUPLING FROM THE DRIVER OR TO THE ANTENNA COUPLER SUGGESTED BY W3ESH

across a considerable portion of the coil. In this way a similar LC ratio may be maintained on the various bands. Second idea is from W3ESH. It is a method of coupling across a condenser in series with the two halves of the tank. The idea is that an ordinary link would be very loosely coupled with the coil switched to the high-frequency posi-

tion and that this method *may* give fairly constant coupling on all frequencies.

And now a few honorable mentions to the problem-solvers who were in the running until the last selection: W1IBF; W1DDE; W1JZU; W2GTA; W3ESH; W9TVB.

Finally, we present Problem Four together with the contest rules:

Problem No. 4

OUR hero's ham progress was halted most abruptly a couple of days ago. Trying to make some adjustment on the final of his present rig he managed to get his wrist against the stator of the final tank condenser. He is alive to-day simply because he was sufficiently unbalanced in his stance to be thrown clear in the first violent convulsion. The three-inch burn on the back of his hand, after prompt medical treatment, seems to be healing. But the shack, even to-day, reeks with the odor of burning meat.

Our pal until now laughed about getting bumps from the rig. "Part of the game," he would say. To-day he has a more serious slant on the thing. "Variable links or no links," he says, with considerable feeling, "I'm doing no more work on the new layout until I get the right idea on a method of protecting myself and my friends against a sudden death—a shack full of underfed rattlesnakes would be safer than the present rig."

We told him that in the big laboratories they put all the gear in a big glass-fronted cage (even if it is only a 210) then running strings and flex couplings to the controls. Power can't come on until the operator gets outside, closes the door and pulls the switch. "Too expensive and clumsy," he replies. "And don't come across with the idea of just putting in a big red warning light," he adds. "The darn things burn out at the wrong moment."

And so we're left with the problem. What is a guy to do when he wants real protection but can't swing a complete cage and interlock switching system? How can he provide an infallible automatic warning that the rattlers are off the leash and in a nasty mood? Must he be content with an adequate warning, or is there not some way of also getting complete protection without undue complication and expense?

Solutions should be in before April 20th. The wrist should be all repaired by then and our hero will want to get started.

(Continued on page 55)

Inverse Feedback Applied to the Speech Amplifier for the Amateur 'Phone Transmitter

A 125-Watt Output Unit Using Transmitting Beam Power Tubes

By J. B. Carter*

THE strides radio has made in the last year or so have drawn a never-ending succession of "ohs" and "ahs" from even those closely associated with its intricacies. While some of the newer developments are too expensive to be used outside of research and experimental laboratories their value nevertheless, sooner or later is bound to reflect into the amateur field. A laboratory achievement incorporating a new type of stabilized feedback which permits controlling the overall frequency response, lowers distortion and materially cuts tube noise to a minimum is presented herewith. This feedback method may be applied to various types of modulators, and by way of illustration is here used in conjunction with a pair of the new RK39 beam power tubes to provide an audio output of 125 watts.

FUNDAMENTAL PRINCIPLES

The action of a vacuum tube is such that the signal voltage at the plate is 180° out of phase with that impressed on the grid.

In Fig. 1-A

$$e_s = e_o - e_f$$

where

e_s is the effective voltage impressed on the grid.

e_o is the available signal voltage.

e_f is the voltage fed back from the plate (e_f will subtract from e_o if negative feedback is used, otherwise oscillation would occur).

Now let us consider what happens in Fig. 1-A if the following conditions exist:

(1) Gain of stage with no feedback = 10.

(2) Resistors in feedback network are of such value that $\frac{1}{5}$ of the output signal is fed back to the grid.

(3) Signal = 2 volts.

At first glance, this condition would seem to indicate that with two volts signal input, an output of 20 volts would be obtained. Since one-fifth of the output is fed back, 180° out of phase, it would seem to be 4 volts, which would be more than the input signal voltage. What actually happens may be seen more clearly by a glance at the following equations:

(a) Plate signal voltage = 10 times effective grid signal voltage (e_s). (Because gain of stage is 10.)

(b) Feedback voltage (e_f) = $\frac{1}{5}$ plate signal voltage. (Resistors in feedback network set for this value.)

Therefore, from equations (a) and (b):

(c) Feedback voltage (e_f) = $2 \times$ effective grid signal voltage (e_s).

But from Fig. 1-A effective grid signal voltage (e_s) = available signal voltage (e_o) - feedback voltage (e_f). So to secure same output voltage since $e_f = 2 e_s$, Equation (c), the available signal voltage (e_o) must = 3 times effective grid voltage (e_s).

In other words, it is now necessary to impress three times the signal on the stage to obtain the same output as before feedback was added. The overall effective gain has been cut to one third. From these equations the gain may be calculated no matter whether the feedback voltage is one millionth of the plate signal voltage or equal to the plate signal voltage.

* Kenyon Transformer Co., 840 Barry St., New York, N. Y.

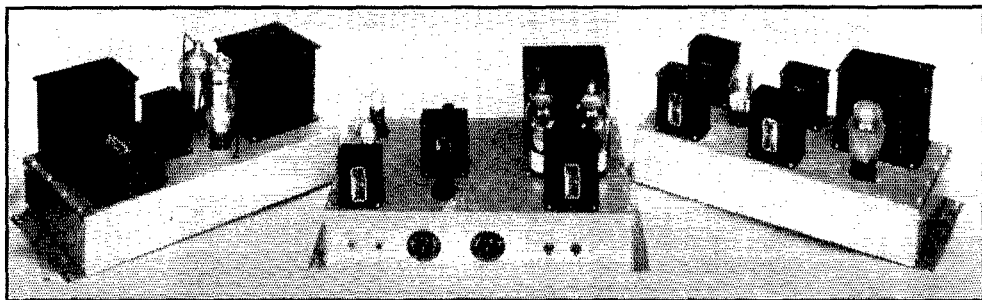

THESE THREE UNITS COMPRISE THE COMPLETE AUDIO SYSTEM WITH POWER SUPPLIES

FREQUENCY-CHARACTERISTIC CORRECTION

Let us consider the use of feedback for frequency characteristic correction. Any audio stage will have changes in gain over the frequency

and the low frequency response may be boosted up to the full gain limit, which occurs when the feedback resistor is short circuited, as is shown in Fig. 3-B.

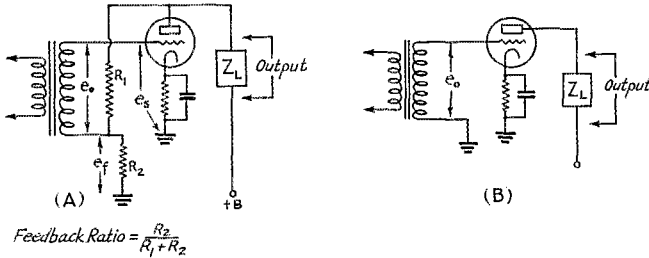

FIG. 1—A SIMPLE TYPE OF INVERSE FEEDBACK (A) CONTRASTED WITH A CONVENTIONAL AMPLIFIER (B)

range. Suppose the conventional stage in Fig. 1-B has a gain of 10 at 1000 cycles, and an input voltage of 2 volts. Thus the output voltage is 20 volts. The stage has a frequency characteristic such that at 50 cycles, the gain drops to 5, and at 10,000 cycles drops to 8. Thus, to maintain the output voltage constant, the following will hold:

Freq.	Gain	e_i	Output Volts
50	5	4	20
1000	10	2	20
10,000	8	2.5	20

Now let us investigate Fig. 1-A with the same output voltage of 20 volts. An input of 6 volts will be necessary at 1000 cycles, since the effective gain of the stage has reduced from 10 at 1000 cycles without feedback to 3.33 with feedback. Now, remember that at 50 cycles the gain of the stage without feedback was 5, and at 10,000 cycles 8. If we maintain the same 20-volt output, the following table shows the behavior of the stage with feedback at 50, 1000 and 10,000 cycles:

Freq.	Output	e_a	e_f	e_o
50	20	4	4	8
1000	20	2	4	6
10,000	20	2.5	4	6.5

Examination of the tabulation of gains with and without feedback shows that with feedback the changes in gain over the frequency range are much less. This will result in a practically flat response over the range, as illustrated in Fig. 3-A.

Freq.	Gain No Feedback	Ratio to Gain at 1000 cyc.	Gain Full Feedback	Ratio to Gain at 1000 cyc.
50	5	.5	2.50	.75
1000	10	1.0	3.33	1.0
10,000	8	.8	3.08	.93

Furthermore, by shunting the feedback resistor, R_2 , with a choke of the proper inductance the feedback at low frequencies will be reduced,

This is also true for the high frequency response, if the feedback resistor R_2 is shunted by a condenser of correct capacity. This, however, is not necessary as a rule, because the distributed capacity in the circuit effectively shunts the feedback resistor and thus affects the response when feedback is used. Should the frequency characteristic be such that at some point the gain increases, as sometimes happens, feedback will also tend to correct this condition.

CURING DISTORTION AND NOISE

The second application of feedback is in a stage which adds distortion to the signal in amplifying it. Assume that to the 20-volt output in Fig. 1 there is added by the stage a 5-volt third harmonic. Now, with the gain of the stage remaining 10, we feed back 2 volts of fundamental, and thus $\frac{1}{2}$ volt of third harmonic. This harmonic is amplified so that its value is 5 volts in the output, but it will be 180 degrees out of phase with the harmonic generated in the tube. Thus it will be

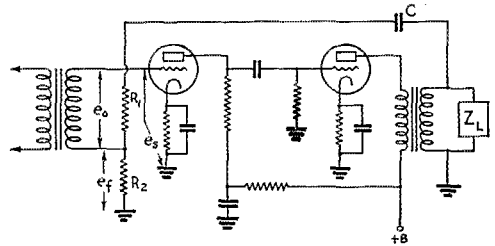

FIG. 2—INVERSE FEEDBACK OVER TWO STAGES

It is important to get the right phase relationships so that the feedback is negative instead of positive. Oscillations will occur in the latter case.

seen to be equal and opposite to the undesirable voltage, cancelling it out. In connection with this, it is well to note that the amount of harmonic to be corrected for must be known and the amount of feedback adjusted accordingly. If a feedback voltage of double the value had been used in this case, the stage would have been over-compensated and little benefit would result.

Another application is the elimination of hum. If, added to the output voltage of the stage by a poorly filtered plate supply, there is a 2-volt 120-cycle ripple, it becomes necessary to make the feedback voltage such that 2 volts of 120-cycle ripple appears in the output due to feedback to cancel the original ripple. This necessitates 0.2 volts of ripple appearing across R_2 .

It now becomes apparent that to cure hum, distortion, and noise introduced by the stage, the feedback ratio must be the reciprocal of the gain of the stage in order to be effective. This will be a minimum limit, and larger feedback ratios may be used. This feedback ratio should theoretically equal $\frac{R_2}{R_1 + R_2}$. But due to the shunting effect of the tube, and the reflected shunting effect of the output system, this may or may not hold true. It is usually a good start for an approximation, however. Now it can also be seen that the feedback ratio desired to correct the frequency response of the stage may not be just the best thing to eliminate hum, noise and distortion, and a compromise must be reached which will approximately correct both. As a general rule, in a well-designed amplifier hum, noise and distortion are small enough so that if they are not entirely eliminated, no harm will result when the feedback ratio is made suitable to correct the frequency response. It is with this in view that feedback over several stages is used.

FEEDBACK OVER MORE THAN ONE STAGE

In Fig. 2 we have two stages whose total gain is 100. The feedback ratio is made such that if there is 100 volts output, 10 volts will appear across the feedback resistor R_2 . Now, in order to give 100 volts output the input voltage e_0 must be 11 volts, reducing the effective gain of the amplifier to 9.1, and making the output voltage relatively independent of the gain of the two stages. Relatively large changes in gain will produce only

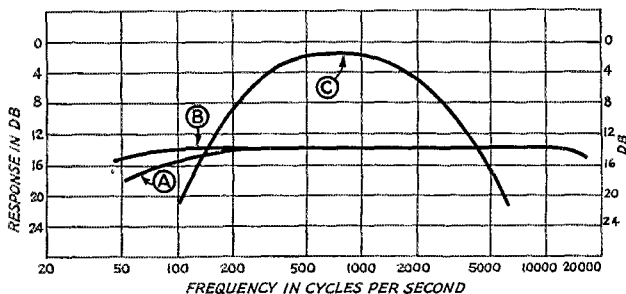

FIG. 3—THESE CURVES SHOW THE EFFECT OF FEEDBACK IN VARYING THE FREQUENCY CHARACTERISTIC OF THE AMPLIFIER OF FIG. 4

A—full feedback; B—feedback adjusted to raise the low-frequency response; C—feedback adjusted to give a frequency characteristic which passes voice frequencies only.

minor shifts in output for a constant input. We must expect a serious loss in gain if the full benefits of feedback are to be realized. This means either that the amplifier must have gain to spare before the feedback can be incorporated, or else more gain must be added to an existing amplifier to which feedback is to be applied.

It will be noted that the feedback is made from

the secondary of the output transformer in Fig. 2. If we attempt to feed back from the plate of the second tube the voltage across R_2 would be in phase with the input and the amplifier would oscillate. By going to the secondary of the transformer, we may choose the correct polarity to give inverse or negative feedback.

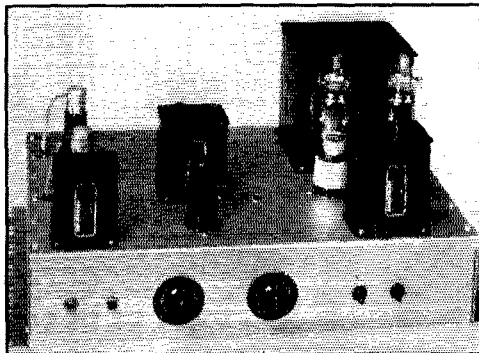

A CLOSEUP VIEW OF THE SPEECH AMPLIFIER AND MODULATOR WITH CONTROLLABLE INVERSE FEEDBACK

Using a pair of RK-29's as Class AB₂ Output tubes, this unit will deliver an undistorted audio output of 125 watts. The frequency characteristic can be altered to give reproduction of voice frequencies only, or can be made practically flat over the usual audio range.

Several precautions must be observed when using feedback. If feedback is made over two or more transformer-coupled stages, the secondaries of the transformers must be resistance loaded if oscillation is to be avoided. If used over three stages, two may be poor in response, but one of the three must be quite linear, so that phase shift will not be likely to cause oscillation over the frequency range used.

Inverse feedback is very effective for driver stages, as it tends to reduce the regulation of the driver tube or tubes and of the driver transformer, allowing the driver to be pushed beyond its customary level without serious distortion occurring.

Another possibility of feedback is over a complete transmitter from r.f. final to audio input, to reduce the hum, distortion, and noise inherent in both the audio and r.f. units. Such a setup is quite complicated and difficult to adjust, due to the large difference in levels and the serious phase shift of the transmitter. This type of feedback is accomplished by the use of a detector or demodulator in the r.f. output, coupled to the audio input.

A speech amplifier-modulator incorporating several of the principles described is illustrated in the photographs. The RK39 beam power tubes

used in the output stage will easily give an undistorted output of 125 watts—sufficient to modulate a 250-watt carrier. Since the audio ratings on these tubes have not previously been published, we list them below:

Values for Two Tubes

Plate voltage.....	750 volts
Screen voltage.....	250 volts
Zero signal screen current.....	6 ma.
Max. signal screen current.....	25 ma.
Zero signal plate current.....	60 ma.
Max. signal plate current.....	230 ma.
Grid voltage.....	=25 volts
Plate to plate load.....	6400 ohms

As the circuit diagram, Fig. 4, shows, several different types of feedback are used in the modulator. The first, from plate to grid of the first tube, serves to compensate for the response of the input, and gives the highs and lows a slight boost to maintain a flat response in the low level stages (Fig. 1). The second feedback (Fig. 2), from the grids of the RK39's to the grid of the 6C5, further flattens the response, and materially aids in reducing distortion in the 6C5, 6N7, and the driver transformers. Later it will be shown how this feedback is used in a different application actually to reduce the low frequency response for voice

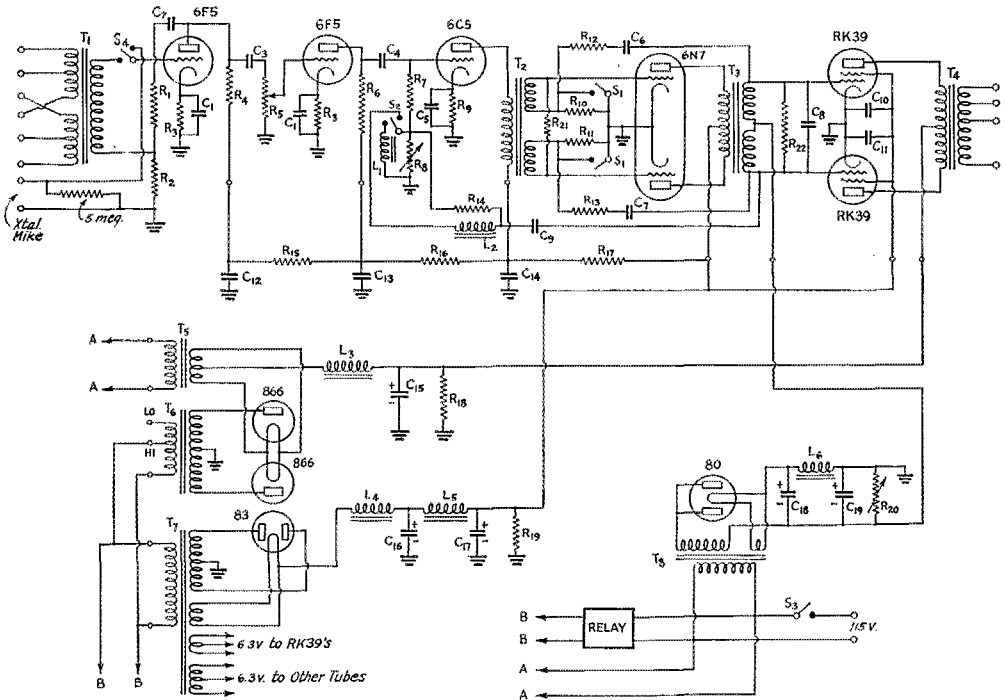

FIG. 4—CIRCUIT DIAGRAM OF THE RK39 MODULATOR AND POWER SUPPLIES

- | | | | |
|--|---|--|---|
| R ₁ , R ₂ —250,000 ohms, ½ watt. | C ₁ —10-μfd. 50-volt electrolytic. | henrys, 250–50 ma. (T-508). | d.c. 300, 250 and 200 ma. (T-462). |
| R ₃ —3500 ohms, 1 watt. | C ₂ , C ₃ , C ₄ —0.1-μfd. paper, 400-volt. | L ₄ —Swinging choke, 10–25 henrys, 165–30 ma. (T-515). | T ₅ —Filament transformer, 2.5 volts, 10 amp. |
| R ₄ —500,000 ohms, ½ watt. | C ₅ —10-μfd. 50-volt electrolytic. | L ₅ —15 henrys, 165 ma. (T-154). | T ₆ —740 or 900 volts each side c.t., 300 ma. (T-656). |
| R ₅ —500,000-ohm potentiometer. | C ₆ , C ₇ —0.1-μfd. paper, 400-volt. | L ₆ —30 henrys, 90 ma. (T-153). | T ₇ —Power transformer, high-voltage winding 325 volts each side c.t., 100 ma.; 5 volts, 2 amp.; 6.3 volts, 3 amp.; 6.3 volts, 2 amp. (T-206). |
| R ₆ —500,000 ohms, ½ watt. | C ₈ —0.01-μfd. paper, 400-volt. | T ₁ —Microphone or line to grid with tapped primary (T-1 or T-2). | T ₈ —Bias supply transformer, 75 volts, 70 ma.; 5 volts, 2 amp. (T-201). |
| R ₇ —250,000 ohms, ½ watt. | C ₉ , C ₁₀ , C ₁₁ —0.1-μfd. paper, 400-volt. | T ₂ —Interstage audio for coupling 6C5 driver to Class-B 6N7 (T-251). | (Type numbers refer to Kenyon transformers.) |
| R ₈ —250,000-ohm variable. | C ₁₂ , C ₁₃ , C ₁₄ —4–4–4-μfd. electrolytic, 450-volt. | T ₃ —Coupling transformer, 6N7 to Class-AB2 6L6's (T-271). | Relay—20-second Ward-Leonard time delay. |
| R ₉ —1000 ohms, 2 watt. | C ₁₅ —4-μfd. paper, 1000-volt. | T ₄ —Output transformer, RK39's to 4000-, 6000- or 8000-ohm load. Max. sec. | |
| R ₁₀ –R ₁₃ , inc.—10,000 ohms, ½ watt. | C ₁₆ –C ₁₉ , inc.—16-μfd. electrolytic, 400-volt. | | |
| R ₁₄ —250,000 ohms, ½ watt. | L ₁ —30 henry, 25 ma. (T-156). | | |
| R ₁₅ , R ₁₆ —250,000 ohms, 1 watt. | L ₂ —290 henry, 10 ma. (T-155). | | |
| R ₁₇ —5000 ohms, 1 watt. | L ₃ —Swinging choke, 7–26 | | |
| R ₁₈ —30,000 ohms, 50 watt. | | | |
| R ₁₉ —30,000 ohms, 10 watt. | | | |
| R ₂₀ —1000-ohm variable, 10 watt. | | | |
| R ₂₁ —250,000 ohms, ½ watt. | | | |
| R ₂₂ —25,000 ohms, ½ watt. | | | |

applications. A third feedback is from the grids of the RK39's to the grids of the 6N7, serving to preserve frequency response and to minimize the distortion of the 6N7 driver, which must necessarily work fairly hard to drive 125 watts from the RK39's. The reduction of distortion is very noticeable on an oscilloscope and to the ear.

When it is desired to pass only voice frequencies as shown in Fig. 2C, the feedback resistors R_{10} and R_{11} are shorted by switch S_1 and the feedback control R_8 set for maximum feedback; that is, R_8 is at maximum and the switch S_2 closed, shunting R_{14} with L_2 and removing L_1 from the circuit. The action is now such that the lows are attenuated by the parallel choke L_2 which causes the feedback ratio to increase as the frequency decreases, thus cancelling more and more of the input and attenuating the lows. Closing switch S_1 effectively shunts the grids of the RK39's for high frequencies, causing the modulator to pass only the relatively narrow voice band. This band is kept as flat as possible by the remaining feedback in the circuit.

The low-level tubes of this unit are triodes, the 6F5 triode having a realized gain very close to that of a pentode. Provision is made for low- or high-impedance inputs. The first tube is resistance-coupled to the second tube, another 6F5, which is in turn resistance-coupled to the 6C5. The 6C5 is transformer-coupled to drive the 6N7 in Class B. No further discussion of the feedback networks is necessary as the operating principles have been explained in the previous paragraphs. The Class-B 6N7 will deliver sufficient driving power to the RK39 grids to push them to considerably above the 125-watt level with a minimum of distortion, when full feedback is present.

The rather husky output transformer will safely carry the full Class-C load, and since the secondary is tapped the following tubes can be modulated 100%:

1—T-55	1—211C	1—203H	2—RK37's
1—805	1—RK38	1—RK36	2—RK20's

and similar tubes.

It cannot be emphasized too much that feedback is imperative if distortionless operation is to be obtained. Furthermore, in the cases where feedback is used over several stages the feedbacks must be properly connected so that they are inverse or negative. This condition is easily met by connecting one feedback at a time and whenever oscillation occurs reversing polarity of the feedback. That is, should C_6 be connected to the wrong RK39 grid, oscillation would occur. C_6 should then be connected to the other grid and C_7 coupled to the grid formerly tied to C_6 . This is well to remember, since transformer polarity is not always the same and what may be the correct connection in one setup will be wrong in the next. If the completely flat response is not desired L_1 may be omitted, the difference being shown by

the curves *A* and *B*, Fig. 3, *A* illustrating the response with L_1 in the circuit and *B* without it. If narrow-band response is not desired L_3 , S_1 and S_2 may be omitted. The approximate gain of the modulator with full feedback is 120 db. The only controls are the gain control R_5 and the frequency control R_8 . R_8 serves to raise the high and low end approximately 6 db with the other feedbacks connected as shown. When $R_8 = 0$ the modulator will be down about 6 db at 60 and 15,000 cycles, and variations to a practically flat response can be obtained by increasing R_8 .

If a crystal microphone is used, there are two ways in which it may be connected to the first tube. The grid of the 6F5 is switched from the high side of the microphone transformer to an external connection for the crystal microphone. The other side of the microphone may be connected either to ground, as shown, or to the junction of R_1 and R_2 . The first method removes the feedback on the first stage but obviates hum troubles which might be encountered with the second, and, since the feedback is cut out, raises the overall gain. The second is to be preferred, however, if no hum results from its use.

POWER SUPPLY

It will be noticed that a separate plate transformer is used for the plates of the 866's supplying the high voltage for the RK39's. This high voltage supply is amply filtered by a single section, choke-input filter, since a small percentage of ripple is not important. The plate transformer is designed with a tapped primary and is connected to give its higher output voltage as shown. The relatively low voltage to the screens of the RK39's is obtained from the same power system as that used for the driver and low level stages. This and a filter with swinging-choke input aid in giving good regulation for the screen supply of the RK39's.

Bias for the RK39's is obtained by using an 80 tube in a half-wave condenser input circuit, and R_{20} is adjusted to give 25-volt bias. This seems to be quite critical and may be varied a volt or two for best operation of the RK39's. It should be noted that a time-delay relay is used so that the bias is applied to the RK39's before their filaments are excited. When the relay trips voltage is applied to the plates, then the filaments come to emission and by that time the screens have reached working voltage and the outfit is ready to go. It is very important that there be several hundred volts on the plates of the RK39's before any screen potential is applied, or the screen dissipation rating of the tubes will be exceeded, and burnouts may result.

CONSTRUCTIONAL HINTS

The audio chassis should be laid out so as to get the input transformer as far as possible from the output. Furthermore, it is well to keep the

driver tube and its unshielded wiring well away also. Shielding is very important if feedback is to be used, to prevent oscillation of low level stages. All leads more than an inch long should be effectively braid-shielded. A positive ground should be run around the chassis, not just using chassis grounds as these may or may not be effective. It is well to ground the shield leads brought to the controls at the front of the chassis in several places to insure effective shielding.

The power supply is on two chassis, one for the plate transformer T_6 , filament transformer T_5 , choke L_3 and the time delay relay. The rest of the power supply is on the second chassis. In conclusion, if the foregoing observations have been thoroughly followed no difficulty should be experienced in constructing a similar unit.

Directed Vertical Radiation with

Diamond Antennas

(Continued from page 24)

fully used in spans up to 300 feet or more.

When carefully adjusted the winch and pulley system works very smoothly. It is necessary to use a good grade of pulley, especially for the side poles. The proper size of counter weights can be determined only by experiment.

In order to adjust the antenna properly it became necessary to have an instrument with which to detect the presence of standing waves on the feeders (both feeder and dissipating lines). The photograph shows the device which was developed for this purpose. It consists of an r.f. milliammeter shunted across a two-turn coil, a shunt also being placed across the meter. This device gives a measurement of the relative strength of the magnetic field *between* the two conductors comprising the transmission line, and therefore measures the relative current at the given point. The presence of standing waves is readily detected, and the device leaves the line in a symmetrical condition and obviates the necessity of scraping the wire for connections with the resulting uncertainty of contact. Readings may be made rapidly and accurately.

We wish to go on record here and now as stating that if a rhombic antenna is not correctly terminated in its characteristic impedance, the full possibilities of the antenna are by no means realized. We make this statement because many amateurs consider it unnecessary to bother to terminate their diamonds correctly, if at all. When not correctly terminated, reflection occurs at the far end, causing standing waves to appear, thus changing the current distribution which, in turn, changes the radiation pattern. The antenna will therefore exhibit the properties of a resonant system and the impedance will no longer be independent of variations in frequency. When not terminated at all, the antenna becomes a strictly resonant system and acts as a hybrid "V" beam.

It may still have considerable gain, but not that which could be realized. When properly terminated the antenna acts as a non-resonant system, the impedance at the sending end being practically independent of frequency over a two-to-one range of frequency. As a final check on the proper operation of such an antenna, the back-end reception should be slight, and standing waves on the feeders largely eliminated.

Exceptional results include low power QSOs with South African stations who used as low as 0.12 watt input! This amounts to some 128,000 miles per watt over one of the longest paths of communication. It was at times possible to maintain communication with South Africa for 16 hours out of the 24 hours of the day, which is phenomenal when it is considered that the South Africans usually are heard for only a few hours in the morning or evening. The average report from South Africa over a four months period was approximately S8½, with the European reports averaging slightly under S8 for all kinds of conditions and times. It was possible to work Europe in the afternoon hours while using a bug, riding right over the QRM caused by east coast U. S. stations. Although VK3MR told us it was impossible, we succeeded in establishing a communication with him at 1:30 P.M. P.S.T. the long way around, a distance of some 17,500 miles with an S8 report. With the unidirectional antennas employed it was also possible to verify the fact that at times the European signals reach the West Coast the long way around.

In closing, the authors wish to state that, in spite of the difficulty of construction, their choice of a directive antenna lies with the horizontal rhombic because of its elimination of back-end radiation and reception, its flexibility in point of operating frequency range, its controllable vertical radiation properties, and its excellent gain.

Oregon State Convention

Ashland, Oregon, April 17th-18th

STOP, LOOK and LISTEN! The sixth annual Oregon Amateur Radio Convention of the Northwestern Division will be held at Ashland Hotel, Ashland, Oregon, on April 17th and 18th. We of the Ashland Radio Club depend on all A.R.R.L. members and radio amateurs in this state to help us make a success of this annual event and extend a cordial invitation to all. In order to help you show your interest a pre-registration fee of \$2.00 is made and this will be for only a limited time. Besides by registering in advance it will give you a chance on a prize of \$25.00 in merchandize offered by United Radio Supply of Portland, Oregon. The regular registration fee on the day of the convention is \$2.50.

If you write to D. Guy Good, Chairman, 341 Terrace St., Ashland, Oregon, he will be glad to give you further information.

Should You Choose Radio Engineering as a Career?

Practical Suggestions for Determining Your Own Vocational Fitness

By Frederic D. Merrill, Jr.*

At this season of the year, with the end of his high-school education approaching, many a young radio amateur is turning his thoughts to the question of whether or not he should take up radio or communication engineering as a life work. Some who choose to take up higher engineering training will make useful and therefore successful careers for themselves in the profession. Some will ultimately find that they have made a mistake, either before they complete their rigorous course of technical training in college, or, more unfortunately, after they have spent some time in working at one engineering job or another with indifferent success or complete failure. An engineering degree does not make its possessor an engineer. And an interest in amateur radio, no matter how enthusiastic, is not of itself a certain indication that June's high-school graduate should become September's engineering college freshman. In this article the author discusses the various factors prerequisite to choice of radio engineering as a profession, and outlines a procedure of self-examination to aid you in making this all-important decision.—EDITOR.

ADVICE to young amateurs on how to prepare for a career in radio engineering may be summed up in the statement, "Attend a good technical college for four years." But how many of those who seek this advice are actually fitted to follow it? In this article we shall attempt to go still further back into the problem—to explore some of the qualifications of the individual which may indicate likelihood of success (or of failure) before committing him to the arduous and expensive work of studying and then establishing himself in this field.

Some of the types of work available in radio may be classified as follows, in order of increased training required: (1) radio servicing, (2) commercial operating, (3) engineering, (4) research. At least in the last two, collegiate training is almost essential, since the applicants who are considered for these positions usually must have obtained a Bachelor of Science degree. Those without degrees are automatically barred by most of the larger employers, although this rule is not absolutely rigid and individual ability does still play some part in working up into these better positions. Now that we have indicated some of the training that is necessary and what the work is which we are headed for, we shall suggest some of the limits to this article.

Although there are many fine vocational guidance bureaus and counselors in this country it is not possible to expect that, in return for the payment of a fee, you can be assured of 100% success in the vocation which you are advised to follow. As a matter of fact, all predictions are based on *failure* expectancy and not on *success* expectancy; this means that it is far easier to determine in what you will fail than in what you will succeed. Where the least failure is indicated,

*30 Marion Ave., Millburn, N. J.

there the greatest chance for success should exist. It is only in the field of music that the vocational guidance tests are accepted by the experts as having a high degree of accuracy. In practically all the other fields the accuracy of the test is low, although the results are still of sufficient practical value to be worth studying. Even though one may be in his right vocation other factors may prevent success, such as one's fellow workers, the boss, the environment, etc., and this explains some of the nature of the difficulties. Another reason for vocational guidance difficulties is the apparent fact that there are many varieties of positions in each field. For example, in engineering there are (even in radio) production engineering, sales engineering, design engineering, research, and still other divisions. A success in one of these might have been a complete failure in another. You can understand now why I urge caution in applying the discussion and examination that follows.

YOUR AMATEUR ACTIVITY AS A CRITERION

The mere possession of an amateur Class-A or -B license and a transmitting station does not in itself prove anything on vocational fitness, since memory and perseverance may be sufficient for passing the examination.

Much more important than the mere possession of a license is the question of the use to which you put it. It is practically always the romantic appeal of communication over long distances without connecting wires that originally draws us into amateur radio; but unless some of this romance is replaced with a sincere desire for scientific knowledge we do not advance far into the technical side of our hobby. If, friend reader, you spend more than half of your time in message handling or forming radio friendships, your interest in radio engineering as a vocation is to be very seriously doubted.

If more than half your time in amateur radio activity is spent in serious experimenting with receiver and transmitter circuits, then your interest in the technical side is evident. Especially favorable would be the keeping of a laboratory notebook of the experiments you perform — data, observations, conclusions and parallel references to magazines or textbooks. If instead of building your own equipment you purchase ready-made a transmitter and receiver, then I think you will agree with me that radio operating is your goal as a hobby and not technical experimenting.

Your activity in a radio club also furnishes an indication of where your likes rest. Do the other members look toward you as an amateur who can solve their circuit and antenna problems, or are you simply a social member?

Perhaps the way in which you read your *QST* will show your mental processes.¹ If you read the technical articles carefully, this is a favorable indication; on the other hand, a brief examination of the technical dope, and much time spent on the lighter articles and advertisements, does not show much on which to make a decision of adopting radio engineering as your lifelong career. If you are new to amateur radio or do not have much money to spend in this hobby, either of these facts should not discourage you; the important thing is the way in which you use your time.

WHAT YOUR SCHOOL INDICATES

Before we consider what your school work shows, we must first decide something about the standing of your high or preparatory school. If you are a first-rate student in a fourth-rate school, your ability may or may not be equal to that of a first-rate student in a first-rate school. It is very likely that in the inferior school your preparation will not be quite as good as that of the other student. It might be a bit embarrassing to pose this question to the school teachers or superintendent, so the following ways might be used. Ask a former student who graduated and went directly to a well-known engineering college the following fall whether he found the preparation of your school to be adequate. Another suggestion is to write the college where you might like to go and find out whether they accept without examination (called "certifying") the subjects taught by your school; you might even ask their opinion of the adequateness of the preparation your school gives.

Supposing that you have been able to put a rough rating on the standing of your school, we proceed to examine your own mental abilities.

The grades you receive should place you in the upper quarter of your class, speaking from a scholastic point of view. If you are capable of getting into this preferred group but do not try hard to do so, then you show little understanding

of the magnitude of the studying you must do when you go through your freshman year in college. The better your preparation before entering college, the easier you will find your work after you get into college. All the advanced work will be based on the fundamentals offered in high school; and woe unto you if they are not acquired in a solid fashion. So I suggest that you knuckle down to serious study at once. If you are unable to make the high-group rating, then there is some question whether you possess the necessary scholastic ability to wade through four years of the intensive studying required for an engineering degree.

If you have filled the above requirement, then it would be well to consider the economy of time in this connection. If you are slow to learn but, nevertheless, make good grades, your preparation for college should be much more solid than that of the fast learner. The latter can cram in a lot of knowledge in a short time if necessary (even though it may not be a good thing in the long run), while you will find this impossible to do; so that you will have to guard against biting off more than you can chew. For the slower type of individual even an extra year spent on advanced chemistry, physics, and mathematics in an advanced prep school or junior college would be time well spent.

When you cannot find the time for extra student activities such as football or dramatics on account of the time needed for homework, then it is well to realize that in college the work will proceed many times faster. Success in later life is often correlated with participation in student activities, so that leaving out the latter to put all time into studying is not very wise. One prominent eastern engineering college making a study of their unemployed students found that they were distinctly above the average scholastically but, on the other hand, that they were men who had not shared very much in the student life. Possibly those with not quite such good grades did learn through student contacts how to meet people and talk themselves into a job. The moral of this is not to sacrifice all school fun for pure, unadulterated studying. Even an extra year of preparation is better than doing that.

We now proceed to inspect the meaning (if any) of success in studying elementary chemistry and physics in high school. To my mind these subjects are largely descriptive and even the problems given do not involve nearly as much analysis as do several other subjects to be discussed later, and for this reason I doubt that ability in these two subjects has very much meaning relative to aptitude in radio engineering. You can check your interest in technical subjects with these two, however. More significant would be your accuracy, skill and speed in the physics or chemistry laboratory. Here you have to manipu-

(Continued on page 118)

¹ "How To Read and Use Your *QST*," by F. D. Merrill, Jr., *QST*, Feb., 1936.

• I. A. R. U. NEWS •

Devoted to the interests and activities of the

INTERNATIONAL AMATEUR RADIO UNION

Headquarters Society: THE AMERICAN RADIO RELAY LEAGUE, West Hartford, Conn.

MEMBER SOCIETIES

American Radio Relay League
Associazione Radiotecnica Italiana
Canadian Section A.R.R.L.
Československá Amatérská Vysílač
Deutscher Amateur Sende-und-Empfangs
Dienst
Experimenterende Danske Radioamatører
Irish Radio Transmitters Society
日本アマチュア無線聯盟
Liga Colombiana de Radio Aficionados

Liga Mexicana de Radio Experimentadores
Magyar Rövidhullámú Amatőrök Országos
Egyesülete
Nederlandsche Vereeniging voor Interna-
tionaal Radioamateurisme
Nederlandsch-Indische Vereeniging Voor
Internationaal Radioamateurisme
New Zealand Association of Radio Trans-
mitters
Norsk Radio Relæ Liga
Österreichischer Versuchssenderverband
Polski Związek Krotkofalowcow

Radio Club Venezolano
Radio Society of Great Britain
Rede dos Emissores Portugueses
Reseau Belge
Reseau des Emetteurs Français
South African Radio Relay League
Suomen Radioamatööriyhdistys r.y.
Sveriges Sandareamatörer
Unión de Radioemisores Españoles
Union Schweiz Kurzwellen Amateure
Wireless Institute of Australia

Conducted by Byron Goodman

QSL:

International DX has become such a common occurrence in recent years that the handling of QSL cards has become an enormous task for the various societies throughout the world. Ordinarily one doesn't visualize the thousands of cards that pass through the offices of the various QSL Bureaus each month until it is brought home forcibly by a visit to the Bureau or a long delay in receiving an "extra-special" card. With the idea in mind of minimizing the delay as much as possible, several new policies have been adopted or, we should say, crystallized.

Heretofore, a great deal of time and effort has been expended by the Bureaus and Managers in handling "Heard" or "Listener" cards and their acknowledgments. In past years, or when the 28-Mc. band was first opening up, listeners' cards were valuable to the recipient, showing as they did that his tests had not met with complete failure. But now any high-powered station, and especially 'phones, will receive so many listener reports that it is practically impossible for him to acknowledge all or part of them. The result is that he files them in the waste basket, the SWL is disappointed because he received no reply but, worst of all, the QSL Bureaus or Managers have wasted valuable time and had their service delayed through the handling of the cards. Many stations have asked their QSL Managers not to include listener cards in the envelopes they have on file. The A.R.R.L. must therefore go on record as saying that they no longer can give any assurance that listener cards will be delivered. We do not know how many other countries have adopted this policy, but they will be reported in this column as soon as we are notified.

This does not mean that the SWL is "out in the cold." Far from it. By sending his cards directly to the station for which they are intended, he will have a better chance of receiving an acknowledgment, and his report, reaching its destination sooner, will be more valuable.

Somewhat along the same lines, it should be pointed out that cards should be sent directly to

Raymond Coombs

It is with deep regret that we report the passing of Mr. Raymond Coombs, organizing secretary of the South African Radio Relay League. Active in S.A.R.R.L. affairs since the beginning, Mr. Coombs was more responsible than any other individual for the development and success of the society. Operator of an outstanding DX station in the early days, the pressure of personal affairs kept him from much active work on the air in recent years. But in I.A.R.U. affairs, one never thought of the S.A.R.R.L. without thinking of Raymond Coombs. The I.A.R.U. extends its sympathy to the S.A.R.R.L. on the loss to them and to organized amateur radio.

the foreign QSL Bureau in the country for which the cards are intended. Amateurs in foreign countries should send cards intended only for W, K, VE, and N, to the A.R.R.L. Only cards intended for G, GM, GI, BRS, and A.A., should be sent to the R.S.G.B. VK, ZL, SU, etc., cards should be sent directly to the Bureau in those countries, and not to the R.S.G.B. In cases where there is no

Bureau in the country, and no QRA is given in the Call Book, cards can be sent to the A.R.R.L., whereupon every effort will be made to have the card reach its destination but with no guarantee of delivery.

By cooperating with the Bureaus to this extent, a better service will be rendered all around, and fewer cases of "I never gotcha card" will result.

QSL Bureau:

Two corrections should be made in the list of Bureaus:

Australia: R. Jones, 23 Landale Street, Box-hill, Victoria.

Guam: C. R. Spicer, K6OJG, Naval Communication Office, Agana, Guam.

South Africa:

From R. C. H. Taylor, secretary of the S.A.R.R.L.:

"As with most of our sister-societies the question of off-band operation and other breaches of the regulations has had to be faced from time to time. The S.A.R.R.L. is making a determined effort to get to grips with the problem, and a number of Observers have been appointed, their duties being to keep a check on all amateur operation and to offer kindly and constructive criticism to those who need it. The system is intended to be preventive rather than corrective and, it is hoped, will result in a marked improvement in local operation."

Dominican Republic:

We regretfully report the passing of Mr. M. Valverde Gazan, HI2K, president of the L.R.D.A., on February 16th. The radiogram, from HI6O, announced also that the vice-president, Dr. Leoncio Ramos, HI3L, is temporarily in charge.

How Would You Do It?

(Continued from page 45)

And here is the dope on the rules and prizes, repeated for the benefit of those who may have missed the last issue.

1. Solutions must be mailed to reach West Hartford before the 20th of the publication month of the issue in which the problem has appeared. (For instance, solutions of problem given in the April issue must arrive at *QST* before April 20th.) They must be addressed to the Problem Contest Editor, *QST*, West Hartford, Conn.

2. Manuscripts must not be longer than 1000 words, written in ink or typewritten, with double spacing, on one side of the sheet. Diagrams and sketches may be in pencil, but must be neat and legible.

3. All solutions submitted become the property of *QST*, available for publication in the magazine.

4. The editors of *QST* will serve as judges. Their decision will be final.

Prizes of \$5 worth of A.R.R.L. station supplies or publications will be given to the author of the solution considered best each month, \$2.50 worth of supplies to the author of the solution adjudged second best. The winners have the privilege, of course, of stating the supplies preferred.

—R. A. H.

I.R.E.-U.R.S.I. Meeting

THE annual joint meeting of the Institute of Radio Engineers and the American Section of the International Scientific Radio Union will be held in Washington, D. C., on April 30, 1937. This all-day meeting is an important feature of the week which attracts to Washington every year an increasingly large number of scientists and scientific societies. Papers on the more fundamental and scientific aspects of radio will be presented. There will be two sessions at the building of the National Academy of Sciences, 2101 Constitution Avenue, Washington, D. C., beginning at 10 A.M. and 2 P.M. Papers will be limited to fifteen minutes each to allow time for discussion.

New Receiving Tubes

QUITE a number of new receiving tube types have been announced within the past month or so. Most of them are simply "G" type tubes duplicating, in octal bases, types already in existence. A few have different characteristics from existing types, but a glance over the list hardly would disclose anything likely to set the amateur world on fire. Here's the dope:

1G5G

The 1G5G is a new low filament-current battery pentode particularly designed for operation from a 90-volt plate supply. Tentative ratings and characteristics are as follows:

Filament voltage.....	2.0 volts
Filament current.....	0.12 amp.
Plate voltage.....	90 volts max.
Screen voltage.....	90 volts max.
Grid voltage.....	- 6 volts
Plate current.....	8.5 ma.
Screen current.....	2.7 ma.
Plate resistance.....	135,000 ohms
Amplification factor.....	200
Load resistance.....	8500 ohms
Power output.....	300 mw.
Total harmonic distortion.....	9 percent

The 1G5G has an octal base with 7 prongs.

5T4

The 5T4 is a metal full-wave rectifier tube similar to the 5Z3 except for smaller filament current drain. Characteristics are as follows:

Filament voltage.....	5 volts
Filament current.....	2 amp.
Max. a.c. voltage per plate.....	450 volts
Max. peak inverse voltage.....	1250 volts
Max. d.c. output current.....	250 ma.

(Continued on page 122)



OPERATING NEWS



Conducted by the Communications Department

F. E. Handy, Communications Manager

E. L. Battey, Asst. Communications Manager

WHEN these words reach the reader *A.R.R.L.'s Ninth International DX Competition* will have passed into history. New WACs will result; new records will have been made; the QSL bureaus of the world will again feel the burden of the exchange of "worked" cards that always follows, in the true ham spirit. We shall look eagerly for reports of the c.w. and 'phone sections of our world-wide contest. Depending on analysis of results and suggestions received, plans for the future of this activity will be made. Our "on the air" observations indicate that during at least the first part of this season's tests, frequency observance was not entirely satisfactory. In addition to new QRM levels, this will mean a "new high" in pink tickets sent by the government monitoring stations for this period. That should teach proper respect for Uncle Sam's regulations if the spirit of fair play is not observed by some individuals.

Self-policing by A.R.R.L. official observers was always a basis for disqualifications in the competition, until the number of observations became insufficient for us to use as grounds. We have a proposal for next year. It is this: that we ask the F.C.C. to give us special cooperation and monitoring during this activity of ours; then without fear or favor we disqualify every DXer that receives a government notice for off-frequency work during the period of the contest, giving full publicity to the list of calls disqualified.

Off-frequency operation in normal amateur work has for years fallen to nominal proportions. Accordingly it is something of a shock to see it become a contest problem. It savors more of poor sportsmanship than of carelessness. Although carelessness can be the excuse, it is not a good reason for getting off frequency; not in these days of ample methods of calibration, with much inexpensive and reliable equipment available for personal monitoring of one's signal. The standard frequency transmissions arranged by A.R.R.L. are utterly reliable; good standards also are no further away than one's nearest broadcasting station. It is not safe to depend on where one hears amateur signals as marking the limits of the amateur band, although calibration of many modern receivers has reached the point where stability (or known drift characteristics) make it possible to use the super-het as a frequency divider, once the frequency is known from a suitable standard.

The Handbook is full of information on monitors and frequency meters. The station without frequency and note checking equipment of some sort is increasingly known as one that is not up with the times. A station without ability to keep on frequency is a pretty poor sort of a station (not modern) we think. A.R.R.L. presumes in announcing its competitions that sportsmanship will be observed, with full adherence to government regulations, at the same time operating principles are developed and domestic and international operating enjoyment made possible. We propose to insure fair play even if we have to disqualify a large number of participants, and it is quite likely that the disqualifications in our next big activities should extend equally to the matter of poor notes and other violations of regulation. Are these proposals fair enough? Any alternative suggestions? What do you think?

's funny how the same folks who have the organization idea, and make it a point to hold appointment as Official Relay Station or Official 'Phone Station, maintain leadership in amateur operating activities. For instance, in looking over the results of the last A.R.R.L. Sweepstakes (full report to appear soon) we find that of the seven leading stations, W1EZ, W6KFC, W3BES, W3EHW, W9LLW, W9RQM and W1BFT, that five of those stations are O.R.S.! W1EZ used only 100 watts. A single type '10 was used at W6KFC too—tie that! It's the same story among the O.P.S. We were checking up on the number of W.A.S. (worked all states) certificates issued thus far made on 'phone and found that the majority of holders were O.P.S. Only 1.5 per cent of the W.A.S. certificates issued have been issued for "phone only" work. Three of the four W.A.S.'s endorsed for 'phone are held at Official 'Phone Stations. W8LJZ, W6ITH, W4EEE, and W6ETX are the holders of W.A.S. endorsed for 'phone.

In another month A.R.R.L. Directors will be bound for Hartford for the annual meeting. Your Director is your personal representative on the Board of Directors. The Board considers many matters of policy and has the nice job of finding out what proposals are for the greatest good of the greatest number, which of the many proposals placed before it are practical, which are imprac-

tical. All ideas have to be studied in the light of their possible effects and your desires. Your Director will appreciate it if you will write him your thoughts and opinions. He will receive from others ideas for reducing band congestion, for spreading occupancy on some of our higher frequency bands, for changes in regulations. Unless he hears from you, and you are in contact with your elected Director or his advisers, it will be difficult for him to know your opinions as an individual amateur. So we conclude with the suggestion that you write your Director, after due consideration of that large subject which we know as Amateur Radio, and after thinking of its past, present and future.

—F. E. H.

QRR—Oregon

THE period February 1st-6th found Oregon amateurs engaged in some well handled emergency work. Severe rain, snow and wind storms on January 31st and February 1st cut off all wire service from Eugene and the Coos Bay area (Marshfield, North Bend, Coquille, Reedsport, Bandon, Port Orford). Amateur radio provided the only communication. Eugene wire service was restored on February 4th, but towns in the Coos Bay district depended on amateur radio for from four to six days. Preparedness and experience went hand in hand to make possible the efficient handling of emergency communication—members of the A.A.R.S. and the A.R.R.L. Oregon Emergency Net found their training and systematized operation of great value.

In Eugene, W7KL, with W7AYN as relief operator, was on the air each day from February 1st to 5th from 8 A.M. to 11 P.M. Operation was on 3.5- and 7-Mc. c.w.; 684 messages were handled, including some for the Red Cross, Police, National Guard, State Highway Dept., Hospital, Western Union, Postal and the Telephone Company. Perhaps the most outstanding bit of work done by W7KL was the locating of serum needed within a few hours to save the life of an infantile paralysis patient at the local hospital. W7SY, W7EZL, W7FNO and W7AJV also assisted in this. Working with the A.A.R.S. and O.E.N., W7KL maintained schedules with W7BXQ, W7AXJ, W7DMK and W7SO.

The A.A.R.S. Net operated under the control of W7BXQ. All work was in the 3.5-Mc. band at night and on 7 Mc. in the daytime. At Marshfield, W7DMK, W7FAL and W7BLN were on the job, working with the A.A.R.S. Net. W7DMK handled 514 messages, mostly for Western Union. W7AVT assisted in keeping DMK on the air from 8:30 A.M. until 11:30 P.M. for five consecutive days—February 2d-6th. Schedules were kept with W7BXQ, W7DUE, W7WR and W7KL, most of the traffic being handled by W7KL. One important message concerning lack of food supplies at a C.C.C. Camp was handled. Outgoing traffic from Marshfield was handled for two days by W7FAL, who worked with W7BXQ. W7BLN assisted the telephone company in locating several of its crews, which were stranded by snow and slides while attempting to repair lines; also handled traffic concerning sickness, death and personals concerning persons delayed in reaching home due to road conditions, etc.; also traffic for the telegraph companies. W7BLN handled 26 messages, scheduling W7AXJ, W7BXQ, W7KL, W7EBQ, W7FAL and W7DMK, and working with the A.A.R.S. Net; he was on the air day and night from February 1st to 6th, operating his own station and acting as relief operator at W7FAL.

For the first two days when Corvallis, Eugene, Albany and Marshfield were cut off, W7AXJ, KL, WR, SO, DDZ, FNO, EZL, FAL, FNS, BLN and AJV handled a total of

4000 words of press. W7EZL, Corvallis, was on the air (3.5-Mc. band) for 47 hours, 55 minutes during the period February 1st-5th, with W7DE, W7BUB, W7DBR, W7DIS, W7ENU and W7EZK as relief operators; 23 messages were handled, including Western Union, illness, weather reports, press, telephone and telegraph, highway commission. Part of the operation was with the Oregon Emergency Net. Schedules were kept with W7FNO, W7SO, Albany, furnished communication for that city using an emergency transmitter.

W7AXJ provided Portland connection in the A.A.R.S. Net. He was on the air from 8:00 A.M. to 9:30 P.M., February 1st and 2nd; 52 messages were handled, 2 personal, 3 press, the remainder for communication companies. Schedules were maintained with W7BXQ, W7KL, W7SO, W7BLN, W7DMK and W7EBQ. W7FNS, Portland, operating on 1804 kc. on February 1st handled 676 words of press with W7FAL. Many service messages between Western Union offices at Corvallis and Eugene were handled via W7EZL, Corvallis, to W7FNO to W7AJV via A.A.R.S. to W7KL, Eugene. Others assisting in the Oregon emergency were W6MDI, W7FGE, W7FBO, W7FHM, W7FHB, W7EWU and W7FIA. To every amateur who cooperated, congratulations on a job smoothly done.

Briefs

Have you a cousin in Detroit? If so, see W8MGQ—his specialty is handling traffic to "Detroit" cousins. He hooked W9PHT, who asked him to take a message to a cousin in that city. This he did, and delivered. His next QSO was W9FTX, who also said he had a cousin in Detroit and "will you take a message"! MGQ suggests a new game with "CQ Detroit cousin traffic" as the general call.

W2CJP believes that he and W9FOL are the only Naprapaths (scientific manipulative therapy) who hold ham tickets.

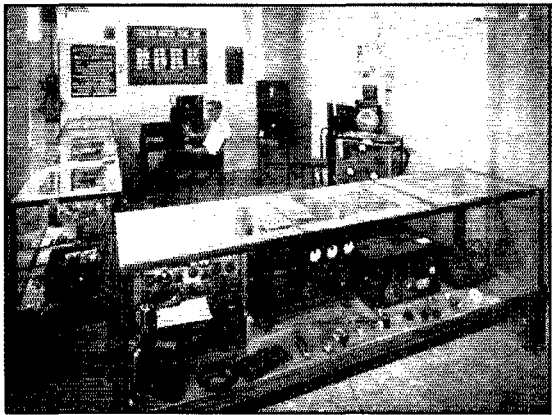

THIS EXTREMELY NEAT AND ATTRACTIVE AMATEUR RADIO EXHIBIT WON THE BLUE RIBBON FIRST AWARD FOR THE STOCKTON (CALIF.) AMATEUR RADIO CLUB IN THE HOBBY SHOW AT THE 1936 SAN JOAQUIN COUNTY FAIR

A station was in actual operation on 1.75-Mc. 'phone manned by W6BEW and W6IKG; some traffic was handled from the fair grounds.

Something new in records is claimed by W9SCH—18,300 "miles per dollar." While using one second-hand '01A that cost him 3¢ he worked W9OBE operating portable in Blytheville, Arkansas, about 550 miles from SCH's QTH. This is the newest way to figure DX—on the basis of "miles per dollar spent for final amplifier tube." Hi!

How's DX?

How:

This month brings glad tidings. Plans are under way for the most sensational expedition of all times and, with the proper support from you, it is bound to succeed. For a long time the DX contingent has been moaning because certain countries had no amateur stations in them and it was, therefore, impossible to add that country to their "worked" list. However, under the present plan, stations will be set up in the rarer countries and, at the end of a five-year program, all countries will have been heard from. The plan consists of first selecting typical operators from each of the nine districts, operators who will be selected because they exemplify everything that is correct and proper in operating. These operators will be elected by popular vote, and it will be illegal for any one man to vote for himself more than once. He will be equipped with a complete station, 1 K.W. transmitter and a.s. super, and given an itinerary which he must follow closely. All expenses will be paid from a fund established by the amateurs staying at home. The price will be \$1.00 per country, so if you contribute \$10.00 you are entitled to contacts in ten different countries. No contacts will be made with stations who have not contributed to the cause and, to avoid confusion, those who have paid their money will sign "PI" after their call, signifying that they are "paid up." Those who have not contributed are not supposed to call these rare DX stations. A feature of the event will be the novel procedure of the DX stations. They will start tuning from the middle of the bands instead of the edges, thus giving some of the fellows inside the bands a chance. While it may be difficult to get used to this revolutionary new procedure at first, it is felt that one can gradually become accustomed to it. (Don't mind us—the DX Contest is making us bitter and, anyway, look what month it is.)

Where:

Many wish to know where "GM" is, so to save you sleep we say that it is Scotland. All stations in Scotland now use the prefix "GM" with their old number and letters. No, it still isn't a separate country, unless you count W8 and W9 as separate Another change in prefix is that of Hungary—they use "HA" now instead of the old "HAF" And a radiogram from the Swiss society, via W2CTC, informs us that Swiss stations will use the prefix "HB1" with their regular call letter when working portable EARR, on 'phone, reported variously on 14,140 kc. and 14,510 kc. by W1BLO and W9NGZ, says he is ex-EA7AI and is operating in the trenches outside Madrid for General Franco. We have no doubt W3DVQ reports a 7-Mc. contact with EA7PI. The Spanish station gave his QRA as "near Cadiz" And W9YEZ's third DX contact was with EA4GE (14,300 kc., T3) one evening W8JK gives the QRA of ON4CGW: Dr. G. W. Westcott, Tondo via Irebu, Congo Belge. The call was changed to OQ5AA on March 1st. The 14-Mc. 'phone signal from a pair of '10's gets a good boost into the States via a folded Bruce type beam The mail to VP7NI, Georgetown, Great Abaco Island, Bahamas, has been returned to us CR9DA is reported as non-existent by the Portuguese authorities at Macau, according to the R.E.P. Don't pass up K6's too quickly—they might be in Guam or some of the other islands. Latest addition is K6OJG (7100 kc., T9), in Guam, who rolls through in the dawn period VP2SL in Santa Lucia now signs VP2LA W3OP reports working CN1CR (7250 kc.) at 6 p.m. The address is Italian Consulate, Taugier Zone, Northern Africa "Mary" of W9TSV, well up among the top-notch XYL ops, reports a swell one in the form of CR5AR (14,250 kc., T8x), Portuguese Guinea, worked at midnight.

When:

No reports on 1.7 Mc. this month, but 3.5 is holding up nicely. You missed a lot of points if you overlooked it in the contest W8CNC reports hearing VU7FY (3650

kc., T9x) but doesn't mention the time W2EYS worked HA8A (3590 kc.) and PAOSS (3536 kc.) Another good one to look for is FA8IH (3510 kc., T9).

The old reliable 7-Mc. band, apparently envious of 20's popularity, has been pulling a few tricks. VK2CI writes to tell of a contact with D3DRF at 12:40 A.M. Sydney time (3:40 P.M. German time), and U3BC at 5:15 A.M. VK time W6JMR says that most of the good DX is on the high frequency end of 40, with Europeans coming in around midnight out there. ON4FE and PAOQF are among the better signals 7-Mc. Asians on the east coast are always news. The latest is XU8HW (7120 kc., T9x), worked by W1SZ at 7 A.M.

On 14 Mc., VP8B (14,400 kc., T7) has been giving a new country to many. He's in there in the evenings on both coasts Some juicy ones worked by W8DOD recently include FB8AF (14,330 kc., T6), CN8MU (14,300 kc., T7c), U9ML (14,340 kc., T9), YV5AK (14,375 kc., T8x), and FK8AA (14,330 kc., T9). The FK was worked at 2:30 P.M., EST We thank W3FLP for correcting us on MX2B. The Manchukuoan signal is T9x at 14,300 kc. and, when the band is right, comes through from midnight to 5:30 A.M. W6CIS lost his chance at a quick WAC when he didn't raise J4CT (14,350 kc., T9), ZS1G (14,400 kc., T7), OA4AK, OZ9Q (14,275 kc., T8), and a



W3PC, THE OUTSTANDING 28-MC. STATION OF CLEM GIBERSON, PORT REPUBLIC, N. J.

Clem has been keeping several DX schedules on ten, and on February 12th, grabbed off a record that should stand for some time. Using 'phone, between 11:44 a.m. and 12:19 p.m. he worked VU2AD, F8ZF, HK1JB, ZE1JR, K6MNV, and W9SIE, for a 28-Mc. 'phone WAC in 35 minutes! He has worked 75 countries on ten, and has a total of 127.

The rig ends up with a '52 buffer driving a pair of '52's in the final. He admits that 990 watts at 3200 volts makes the tubes blush a bit under modulation. A Hammarlund Pro is used, with a home-made pre-selector. Largely responsible for the success is a home-made rotatable beam, consisting of a horizontal half-wave antenna with reflector and director. The wheel that controls the rotation can be seen in the foreground. Clem finds the rotatable beam invaluable in reducing the QRM and building up the weak ones.

VK, all coming through between 9 and 10 p.m., PST W8PKQ has been knocking them off in the low-frequency end of 20, and says around Michigan way the time to listen for K6 and South America is early evening, 9-12 p.m. for Europe and occasional Europeans and Asians in the background. ZB1E has a S8 T9 signal around 11 p.m. W3DAL worked U9MI (14,275 kc., T8) at midnight for his WAC.

Ten is still a honey, with west coast stations taking Europeans away from the east coast and such Then there are fellows like W3PC, mentioned in the illustration, who just don't care what they do on ten Out west, VE5EC thought he would take a look at ten, and from 5 to 8 p.m. worked ZL1DV for a TBTOC, J2CB, VS6AH for a WBE, VK3MR for another TBTOC, and ZL1HY and VK2JX In the center of the country, W9JZJ heard J2IN, GM6NX, and VK3YP all at the same time, around 4:30 p.m. On the east coast, ten is splendid for Europe, Australia, and South America. One of the best South Americans is LU7AZ (28, 150 kc., T8x) W2HYJ of Garden City, L. I., worked G6XN of Garden City, Hertfordshire, for his first G. An indoor antenna and 20 watts input is the rig.

Who:

It is with regret that we report the passing of Buckner A. McKinney, Jr., W5ATF, who died of pneumonia in early February. One of the best-known 7-Mc. DX men, he had been active on the air since 1921 K5AY advises that he has received over 1000 QSL cards during the past year, and has answered every one. However, if you haven't received the card as you should have, a postcard to the Canal Zone station will fix it up W3EXI passes along the word that J2JJ (14,262 kc., T9x) needs Delaware and North Carolina for his WAS. A rhombic puts the signal over here in the grand manner GI6TK is on 14,384 and 14,084 kc. every week-end, looking for contacts with Montana, Idaho, Oregon, Wyoming, Utah, Nevada, Arizona, New Mexico, Texas, and Louisiana An interesting letter from W6MX, the slicker, complains that he still hasn't worked a Cuban, in eight years. But working in the QRM belt at 14,396 kc. with a California KW (160 watts to a pair of '10's) has accounted for such trivia as EL2A, ZU6P, ZT2Q, ZE1JF, OZ3FL, ZE1JZ, D4DLC, PA0AZ, PA0CE, G2PL, SM6WL, and the like. Gee, that's tough about no Cuban! W5CPT, that QRP merchant down Texas way, has not been idle. Aside from knocking off Europeans on 28 Mc., he has been fooling around with low power. Yes, real low power. During a QSO with PA0AZ he was 559x with 6 watts input, 449x with 5 watts input, and 339x and perfectly readable with .154 watts input! No, the plate of the '12A final didn't show a bit of color with the 22 volts on it VP6PZ, whom you remember from way back, has fallen at last. His 300 watt 'phone can be found around 14,020 kc. most any time Another who has succumbed to the magic of the spoken word is CP1AA, whose 'phone is found at the low-frequency edge of the 14-Mc. band The vogue for "round table" on 'phone continues, and a pleasant little soiree that reads like the Call Book was the one recently indulged in by I1KS, VS2AK, YK2BQ, VK2ABG, HAF2I, G5RV, VE1CR, and G5XG. The VS2 contact gave I1KS his 'phone WAC W6JMR is in favor of Pan-American sending Jim Lett around to more islands. Jim was VP4TG in Trinidad and gave W6JMR that country, then went to Antigua and was JMR's first in Antigua If you've wondered at the operating of such a new call as W6ODD, you shouldn't. He's old W3AG, and was WAC ten days after getting his W6 call When W2IXY and SV1KE (14,255 kc., 14,300 kc.) contacted on 14-Mc. 'phone in February they thought it was the first SV-W 'phone contact, but they reckoned without W2DH, who worked SV1NK on 'phone during August last year for the "first."

WAC:

Phone WAC's this year have gone to W2IXY, F8II, W8DQN, W2HMD, VU7FY, ON4DM, W8JVF, W7EXK, W7ALZ, CO7CX, and W3LN W3GMS made WAC seven weeks after receiving his license, using only 60 watts input to a pair of '10's W6N1K is WAC and WAS,

using 12 watts input to a '45 TNT and a two-tube "bloopier" And W4BWZ is WAC on 10 and 20 using a pair of '46's with "the power never exceeding 100 watts." Sissy! —WJPE

Briefs

HOW 69 A.R.R.L. SECTIONS WERE WORKED IN THE A.R.R.L. "SS"! (From W6ITH's letter) "Was happy to W.A.S.! I got more kick out of contacting a new section on the last Sunday afternoon and evening of the 'SS' than anything I know.

"The entire operation was carefully worked out. Operation on 'ten' was continued as long as it was open as the power and conditions on that band would secure a maximum of contacts. As soon as ten went dead W6ITH immediately went to 'twenty' and when 'twenty' went with the wind threw on the 'five,' 'seventy-five' or 'one sixty' transmitters, calling CQ and picking an answer on one of those bands. These three bands were worked until everyone went to bed. Then I would do likewise. No time was spent on 'seventy-five' or 'one sixty,' until the last night when I was a little shy on several sections that would have been easiest in 'ten' or 'twenty,' but were worked on 'seventy-five.' Used the best band for the distance the band was intended with the above noted exceptions.

"All reports were strength 8 or 9. The location is ideal, on top of a mountain high above the harbor of San Francisco. The directive antennas really help. Running a kilowatt transmitter is a real responsibility. W6ITH uses 950 watts input on 'ten' and 'twenty.' Inputs of one hundred watts on 'seventy-five' and 'one sixty' are just about right, no BCL trouble, nor harmonics getting into the hair of the point to point 7800-kc. stations. The power on 'five' is varied experimentally from one to six hundred watts. The QSO on two and one-half meters was really just a stunt so we could report work on all six 'phone bands. Have a 2½-meter channel set up between the office in San Francisco and home in Berkeley, which is a direct shot ten miles across the harbor."

Upon receiving a rush message for the Chicago Police Department from W2OQ, W2CHK called "CQ Chicago." He was answered by W9GMT in the windy city and the message was in the city of destination just four minutes after it left W2OQ!

A.A.R.S. Members Needed

In light of experiences in the Ohio River flood disaster, L. G. Windom, W8ZG/WLH, Fifth Corps Area A.A.R.S. Net Control Station, makes a plea for more Army Amateur Radio System members along the Ohio River. It is desired to cover as many of the river towns as possible, as well as neighboring towns along the course of the Ohio. Any amateurs desiring to help in "organized emergency communication plans" by signing up with the A.A.R.S. should get in touch with W8ZG/WLH for application blanks. Address L. G. Windom, Reynoldsburg, Ohio.

F8JG is making daily transmissions on 65,576-kc. c.w. from 1300 to 1310 GT and from 1800 to 1810 GT, using a crystal rig with 50 watts input and a vertical doublet antenna. On days that conditions are exceptionally good on 28-Mc. and higher frequencies, additional transmissions will be made during the hours from 0900 to 2000 GT, on each hour and half hour for ten minutes. F8JG will listen in after each transmission. Some of the G's working 56 Mc.: G2GB, G2HG, G5FN, G5LB, G5JU, G6PG and G6YQ.

Working 56-Mc. duplex W8QDR and W8KXS provided a description of the wrestling bouts at Pennsylvania State College for fifty architectural engineering students, whose work prevented their leaving the drawing room in the main engineering building. W8QDR was set up at the matside in Recreation Hall, and provided the description, while W8KXS was on the receiving end.

O.R.S. Party Results

Postponed due to the flood emergency, the quarterly O.R.S. Party schedule for January was held February 20th-21st with the usual fine turn-out. Once again W3EOP landed in first place, making a score of 45,253! W6KFC came up to second place with the excellent score of 41,907. Details on the results of the highest scorers are given below, showing number of stations worked, sections worked, stations heard, power used, etc. It's an impressive list! The next party will be held April 24th-25th.

The All-Season O.R.S. Contest closes on May 15th. Awards will be based on the all-season performance of competitors in traffic work and in the quarterly QSO Parties. The trend of final results in the season contest may be determined by examining B.P.L. totals, and Party results—the operator with the best all-around performance (without too much stress on either traffic or the QSO parties—but good work in both fields) will place highest. The beautiful W4NC-Trophy awaits the winner!

Station	QSOs	Sections	Heard	Score	Power	Section
W3EOP	186 + 1	47	27 + 6	45253	900	E. Pa.
W6KFC	121	48	51	41907	70	Ariz.
W3FTK	155 + 5	46	72 + 5	37112	90	So. N. J.
W1AW (Hal)	155	44	55 + 2	36696	210/375	Conn.
W7BSU	101 + 1	48	16	36288	700	Mont.
W8KWA	158	52	42	34206	400/500	W. Pa.
W1TS	139	46	50	33171	50/250	Conn.
W1BFT	145 + 8	37	56 + 5	31968	200/400	N. H.
W2GVZ	110	39	57 + 7	25194	20	No. N. J.
W2HXI	114 + 2	41	15	24902	200	No. N. J.
W1EOB	112 + 1	42	32 + 1	24856	90	W. Mass.

Call	QSOs	Power	Score	Call	QSOs	Power	Score
W8KUN	128	80	24600	W9UIX	102	102	17062
W2HZY	116	55/125	23142	W8AQR	86	35	16051
W8MOT	130	250	21756	W2AHC	88	530	16030
W4DWB	102	50	21333	W3NF	104	300	15992
W8JKO	119	75	20555	W8ONK	84	61	14911
W4APU	101	300	20176	W9SEB	81	95	14586
W8QAN	110	335	19569	W5FJY	86	130	13760
W5KC	101	250	19317	W8GWY	77	85	13375
W3FTU	99	500	19305	W2EYS	74	..	13282
W2IBT	124	50	19124	W3FBM	88 + 1	9	12888
W2HYC	105	250	18909	W8JQE	79	20	12758
W1HKK	95 + 13	100/200	18383	W8DHU	75	50	12328
W8LZK	92	90	18180	VE3QK	67	75	12075
W2BDN	100	250	17816				

Official 'Phone Station News

O.P.S. appointees are working hard in the 1936-37 season O.P.S. Competition, which closes May 15th. The cup trophy (see page 47, Nov. '36 QST for photo) offered by the St. Louis and Kansas City O.B.P. Chapters is proving a decided stimulus to contest interest. Experimental and constructional factors count 50% in scoring, while operating results count another 50% (the standing in three quarterly activities 20%, station log and records 10%, general QSO's and DX 20%). The winner will succeed by consistent work in all fields.

Station	QSOs	Sections	Heard	Score	Power	Section
W8LUQ	31 + 3	19	10	3610	400	W. N. Y.
W8CGU	28 + 2	18	9	3024	200	W. N. Y.
W2DC	26 + 2	13	11	2592	400	E. N. Y.
W8EMV	33	13	6	2301	125	Ohio
W9TTA	27 + 3	12	13	2112	100	Ind.
W3EOZ	37	13	1	2041	700	E. Pa.
W8FIP	21	14	..	1890	200	W. Pa.
W4DCQ	23 + 2	14	1	1806	1000	N. C.
W1DWP	21 + 2	13	10	1755	130	Conn.
W8CJP	18 + 1	13	9	1469	25	W. N. Y.

Call	QSOs	Power	Score	Call	QSOs	Power	Score
W8KNF	23 + 1	120	1368	W8HFR	21 + 1	100/350	912
W1EAO	17 + 7	150	1340	W8CDR	19	40	763
W3BRZ	17 + 2	150	1308	W4QI	13	200	600
W8AAR	19	130	1287	W1COI	12	45	567
W1RO	17 + 2	110	1260	W6ITH	5 + 5	80/1000	546
VE8KM	22	200	1140	W9LLY	13	30	486
W8CSX	16 + 1	75	1089	W1JAH	10	12	476
W8CHT	20	100	1062	W8MOL	14	350	468
W9HSF	19 + 1	90	1020	W8GMI	9	195	282
W8JFC	21 + 1	100	928	W4DGU	15	200	280

W8LUQ made first place—3610 points—in the first 1937 quarterly party, held February 20th-21st. He made 34 QSO's in 19 A.R.R.L. Sections. W8CGU is in second place with a score of 3024—30 stations, 18 sections. A complete list of high scorers is given with full details on accomplishments. The next party is scheduled for April 24th-25th.

Since the last additions to the Official Phone Station roster appeared in QST, the following 65 stations have received O.P.S. appointment:

W1EAO	W3EZ	W6AM	W6FTU	W9WKP
W1DWP	W3CHE	W6MOS	W6BGY	W9TFO
W1RO	W3BFD	W6BUY	W6LYM	W9UWV
W1VU	W3FKD	W6BP	W7AW	W9YGC
W1IH	W4BQD	W6SJ	W8FMH	W9GBQ
W1IAV	W4AWY	W6KTQ	W8ARF	W9MZN
W2IZV	W4CQV	W6BWG	W8M2T	W9RNX
W2FQ	W4DCQ	W6QF	W8ETE	W9IYL
W2ACB	W4DLH	W6MLG	W8NQS	W9LQW
W2ALP	W5PQN	W6BPV	W8MTE	VE1EQ
W2EKU	W5AIR	W6NPD	W9IGZ	VE3AHK
W2BBV	W5FUM	W6JRU	W9VTG	VE4SW
W3EZL	W5HR	W6MMV	W9RPJ	VE4CT

If you have a good 'phone, why not drop a line to your SCM (address in each QST) for application blanks for O.P.S. appointment? A.R.R.L. Headquarters will also be glad to send information regarding O.P.S. work to any amateur who inquires, including sample copies of bulletin material as long as extra copies last. Appointments are not made by Hdq., however, but handled direct with your duly elected administrative Section official, who has full authority in such matters.

One hundred and sixty-two active stations have qualified for Official Relay Station appointment since the last list was printed in QST. All interested hams are invited to drop a line to A.R.R.L. Headquarters or direct to their S.C.M.'s (addresses in each issue of QST) for details on O.R.S. appointment. It is primarily a traffic appointment, for amateurs interested in regular traffic work, schedules, etc. Opportunity is given all O.R.S. appointees to test station performance during quarterly QSO Parties. The pleasure derived from these get-togethers can be fully appreciated only by participation. If sincerely interested in traffic handling, take steps now to obtain O.R.S. appointment!

Newly appointed "reliable's" now included in the roster of O.R.S. are as follows:

W1GMM	W3DQN	W6ETJ	W7FVK	W9LJF
W1FO	W3EDC	W6FYR	W8UW	W9BYV
W1HKK	W3FTU	W6MOS	W8IUY	W9UDH
W1HSH	W3PQ	W6KHE	W8PHY	W9WRK
W1HSD	W3EPM	W6EQI	W8NXT	W9SWC
W1BMW	W3DNU	W6KZN	W8NDL	W9ZCA
W1DMF	W4DQW	W6LHW	W8BFG	W9DLX
W1KPK	W4DRK	W6CW	W8RR-KNP	W9CWR
W1HSX	W4DWG	W6RF	W8DDC	W9WYT
W1AJ	W4AFT	W6NKO	W8HKS	W9WVY
W1PUP	W4BAQ	W6KNO	W8KYR	W9TBI
W1GPR	W4DPP	W6LD	W8JMI	W9NVP
W1KFN	W4DVO	W6MNS	W8NWZ	KA1AN
W1BIB	W4EEP	W6MND	W8PLA	VE1GU
W1JUD	W5FOJ	W7DDY	W8PCW	VE1HJ
W1HYF	W5DNE	W7EZY	W8PQQ	VE1EY
W1GVV	W5FPD	W7AM	W8LZE	VE1BZ
W1AGX	W5FAJ	W7ETU	W7EKT	VE1GK
W1BR	W5ENI	W7AOD	W8PKY	VE2IN
W1HNE	W5FXG	W7BVB	W8DYH	VE2KM
W2DQW	W5FZJ	W7KL	W8CEU	VE2LU
W2BDN	W5DB	W7BQQ	W9QG	VE3HV
W2BQ	W5FBK	W7FCQ	W9FZV	VE3OI
W2JWT	W5GEY	W7BAK	W9FNK	VE3LI
W2JQE	W5DGP	W7PNO	W9KOK	VE3ZE
W2QO	W5DKR	W7DLH	W9WVB	VE3AU
W2JSL	W5FMO	W7TTL	W9MKN	VE3VF
W3AGK	W5BXA	W7STD	W9CAA	VE4WX
W3DXC	W6VU	W7FFQ	W9ESA	VE4LQ
W3ETE	W6GVA	W7DYH	W9PTU	VE4CQ
W3FLM	W6LJA	W7FWB	W9VIL	VE4GC
	W6GYX	W7GEE	W9VTH	VE5OK
	W6UO		W9BEX	

Mike N. Key says, "The best operators in this here ham radio game are the co-operators."

Re: Flood Work

"Unfortunately, however, it is as true in amateur radio as in any other 'game' that there are some participants who insist on playing 'for the grandstand,' those who are not satisfied to play an inconspicuous part when such is the order of the day, but who must make the headlines irrespective of the cost. And it is doubly unfortunate that it is the same type of person who fails to exercise any judgment as to the emergency of a situation. If you listened in much during the days and nights since the FCC issued the order quoted above, you have heard many transmissions illustrating just what we are talking about. A station far removed from the flooded area, for instance, will come on the air calling 'CQ Louisville, URGENT,' and call time and again. All the while there is a station in Louisville on almost the same frequency making a desperate effort to get intelligible speech through the QRM up to an airplane which is circling in search of a landing field. He has medical supplies for the city. Or there is the station who is working heroically to get information as to a passable route from Maysville to Louisville for the truck that is waiting at Maysville for that dope. The truck is loaded with supplies for the Red Cross and is from a city in Georgia. But the QRM is so bad that only a word or two is added to the message at each succeeding transmission. Finally the complete message is received.

"In the meantime what is our HERO doing? Still calling Louisville with urgent traffic. We think it MUST be urgent, so we stick around to see what it is all about. Finally some W8 who says he can clear traffic to Louisville answers and takes the message. The text of the message says: 'Are you safe query wire me immediately.' The W8 comes back, receipts for the message, politely says that he can't promise to clear that message, that messages of far more importance are to be handled first. But something had to be done. No one hearing the call with an urgent message knew the urgency of it, so it was relayed until some ham with sound judgment hung it permanently on the hook until such time as its subsequent transmission would and could cause no interference to stations handling URGENT traffic.

"But in spite of many such incidents, amateur radio came through the flood with flying colors. The heroic work of the hundreds of hams to whose lot it fell to handle the bulk of the traffic and the coöperation on the part of the thousands of us who were not so situated by keeping our transmitters silent, will long be remembered and will be another of the high-lights in the history of Amateur Radio."

—The Tarheel Ham, W4DW, Editor.

While the F.C.C. restrictions on routine operating in the "80" and "160" meter bands were in effect during the flood, one savvyless operator on 3500 was heard to remark, "Conditions are marvelous—no QRM at all!!!!"

Winners, A.A.R.S. Code Speed Contest

The Code Speed Contest transmitted by WLM/W3CXL on January 11th brought about some new amateur records. The contest was run in jumps of 5 w.p.m. from 20 to 60 w.p.m. Each speed was run for five minutes. Solid copy for one minute anywhere in the five-minute transmission determined the ratings. Whenever ties resulted, the contestant having the greatest number of correct consecutive letters was considered the winner.

Results as reported by Captain S. P. Collins, Liaison Officer, A.A.R.S., show Ernest L. Sikes, W4AFQ, as National Winner in the A.A.R.S.-member group, having qualified at 60 w.p.m.!! This is a new record in amateur circles! Second High was Fred C. Bigelow, Jr., W1PI, who made the best showing of those copying 55 w.p.m.! The A.A.R.S.-member winners in each Corps Area are as follows: (I) C.A.—W1PI 55 w.p.m.; (II) C.A.—W2BCX 55 w.p.m.; (III) C.A.—W3CRS 50 w.p.m.; (IV) C.A.—W4AFQ 60 w.p.m.; (V) C.A.—W8KKG 50 w.p.m.; (VI) C.A.—W9KJY 50 w.p.m.; (VII) C.A.—W5BMI 50 w.p.m.; (VIII) C.A.—Sgt. Randall, W5OW 55 w.p.m.; (IX) C.A.—W6MTP 50 w.p.m. A Corps Area competition was held in conjunction with the individual contest. One point was allowed for a

BRASS POUNDERS' LEAGUE

(January 16th-February 15th)

Call	Orig.	Del.	Rel.	Extra Del. Credit	Total
W3FTK	71	50	1748	14	1893
W4PL	22	134	1389	119	1664
W2HZY	41	38	760	60	899
W7KL	437	—	284	176	897
K6NXX	297	77	522	—	896
W1FPL	17	63	674	16	770
W6ITH	108	264	185	203	760
W8KUN	15	43	671	20	749
W6JTV	39	181	374	154	748
W1AKS	77	70	592	—	739
W9BXX	12	37	640	37	726
W7DUE	49	—	616	26	691
W6IOX	33	87	466	80	666
W6MTP	5	17	609	13	644
W3EOP	27	18	520	3	568
W3SN	76	111	844	83	531
W3BWT	33	106	304	82	525
W7DYH	107	14	160	109	528
W6KFC	33	24	447	16	520
W2BCX	52	61	406	—	519
W8MOT	10	2	506	—	518
W8JQE	103	131	220	63	517
W8JTT	224	28	252	13	517
W8PVZ	71	21	412	7	511
W9CXD	38	127	395	—	560

MORE-THAN-ONE-OPERATOR STATIONS

Call	Orts.	Del.	Rel.	Extra Del. Credit	Total
K4IHR	798	565	634	—	2015
W4DUG	1260	805	—	—	1865
W9SYJ	309	358	82	346	1095
W7DMK	77	1	872	—	950
W9FFM	175	300	78	—	553
W9BNT	41	117	345	—	503

These stations "make" the B.P.L. with total of 500 or over. One hundred deliveries—1 Ex. Del. Credits also rate B.P.L. standing. The following one-operator stations make the B.P.L. on deliveries. Deliveries count!

W3QP, 340	W8CSE, 123	W11OR, 103
W7BXQ, 257	W2GGE, 117	W1JXP, 102
W6IMI, 250	W6BQI, 115	W9FQQ, 800
W6GVI, 218	W9KJY, 115	W9TXC, 242
W6LMD, 196	W5EIP, 114	W9AUH, 231
W1IOT, 190	W2GGG, 112	W1CBN, 210
W1UE, 150	W9EJ, 109	W9HQC, 150
W4IR, 137	W1INP, 103	W9MN, 145
		W9FZV, 109

A. A. R. S.

Call	Orts.	Del.	Rel.	Extra Del. Credit	Total
WLM (W6GXM)	103	245	1132	—	1530
WLN (W2BCX)	64	66	425	—	555

MORE-THAN-ONE-OPERATOR STATIONS

Call	Orts.	Del.	Rel.	Extra Del. Credit	Total
WLM (W3CXL)	271	169	2282	—	2722

A total of 500 or more, or 100 deliveries Ex. D. Cr. will put you in line for a place in the B.P.L.

20 w.p.m. copy, two for 25 w.p.m., etc., up to nine points for 60 w.p.m. A handicap factor was also used based on the total A.A.R.S. membership in each Corps Area. The Seventh C.A. won this contest with a total score of 594 points. This represents an average of about 32 w.p.m.

In the non-A.A.R.S.-member group participating, the following results are reported: National High—E.C. Stents, W5GEY, 55 w.p.m. Edwin C. Layman, W4AGP, Second High—55 w.p.m. Corps Area winners, in order of areas, are W1GAE 35 w.p.m.; W2DSV 50 w.p.m.; W8CVS 50 w.p.m.; W4AGP 55 w.p.m.; W8BKM 50 w.p.m.; W9SZL 40 w.p.m.; VE4AB 40 w.p.m.; W5GEY 55 w.p.m.; W6AHK 55 w.p.m.

Prizes were awarded to the winners. All the prizes are not known, but the two national high A.A.R.S. men, W4AGP and W1PI, received a Speed-X key and RK-39 tube respectively.

Runners-up in the Second C.A. A.A.R.S. group were W2GGE 45 w.p.m.; W2DUP 45 w.p.m.; W2INE 40 w.p.m.; W2DBQ 40 w.p.m. In the First C.A. W1CJD copied 45 w.p.m.

A.R.R.L. President Woodruff is sending letters of commendation to the highest rating League Members in each Corps Area: W1PI, W2BCX, W3CRS and W8CVS, W4AFQ, W8KKG and W8BKM, W9KJY, W5BMI, W5GEY, W6AHK.

New 7-Mc. Club

The "330 Club" meets at 3:30 p.m. daily. All member-stations operate on or near 7092 kc. W8MCT is control station. Activities include rag chewing and traffic handling. W2CJP says if you have a crystal between 7090 and 7096 and want to join this group, tune your receiver to W8MCT any afternoon at 3:30 p.m. EST and get instructions. An attempt is being made to build up an inter-state net to include the entire northeast portion of the U. S. A recent four-way 7-Mc. QSO was held by W2CJP, W8MCT, W2IEV and W3GKL.

April Get-togethers

QRM! NITE—The West Towns Amateur Radio Club (Maywood, Ill.) will hold its second annual Smoker for amateurs of the Chicago area on April 3d. The QRM starts at 8:00 p.m. at the club rooms, Washington Boulevard at Fifth Avenue, Maywood. Tickets: \$1.10 in advance, \$1.35 at the door (includes tax). For reservations write the club treasurer, P. O. Box 150, Maywood, Ill. It's going to be a big Nite with eats, entertainment and prizes!

The Auburn-Lewiston Radio Club will hold its annual State of Maine Hamfest at the DeWitt Hotel, Lewiston, April 17th. All amateurs welcome—the more the merrier!

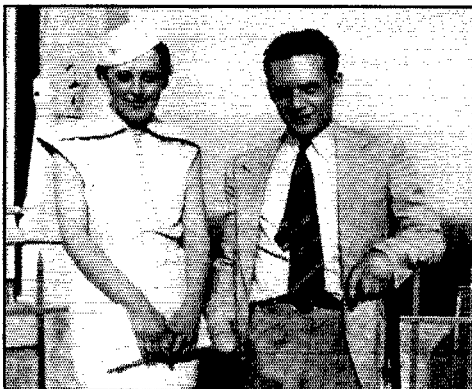

MISS MARJORIE HIERLIHY, VO1S, THE FIRST LICENSED VOYL OPERATOR, AND HER BROTHER OSCAR, VO1I

Their brother Cliff signs VO4C, "Marge" and "Oscar" have long been well known on the 14-Mc. 'phone band. They made a visit to the States in 1936, taking in Boston, New York, Washington, Durham (N. C.) and Atlanta, among other places. In Durham they were royally entertained by Mr. and Mrs. W4OC and W4NP. While in Durham they talked "via amateur radio" with their mother back in St. Johns, Newfoundland. W4UP was their host in Atlanta.

Dakota Division QSO Party Results

W9IJJN was the highest scoring participant in the Third Annual Dakota Division QSO Party held January 8th-10th. His 2252 points won the first prize—a T55. Other prize winners were W9TKX (a bug key), W9TJF (Class B transformer), W9ATP, W9URQ, W9SWC and W9PTU (crystals), W9SEB, W9DGS, W9OWU, W9UKA and W9IDF (A.R.R.L. Handbooks). Complete results by Sections: Southern Minnesota—W9IJJN 2252, TKX 1772, ATP 1601, UKA 860, IDH 860, EFK 508, DNY 472, KDI 225, BVH 200, DH 184, DCM 168, MZN 150, YPT 5. South Dakota—W9URQ 1540, SEB 1060, FOQ 1010, YEZ 720, PGV 624, YNW 552, YOB 440, DIY 400, WES 279, AZR 260. Northern Minnesota—W9TJF 1708, PTU 1212, OWU 1192, ORQ 1164, IGZ 1136, OGZ 684, SYX 540, KQA 40. North Dakota—W9SWC 1104, DGS 1044, VJH 1000, EMY 820, EAP 5.

The A.A.R.S. and N.C.R. use the signal "W" to indicate QRM . . . quite appropriate when one realizes that W's cause most of the QRM!

O.B.S.

The following is a supplement to the list of A.R.R.L. Official Broadcasting Stations in October QST (page 122): W5CJB, W5EHH, W5FUM, W6KZN, W6MQS, W8NQS, W9GBQ, W9WVFV.

ELECTION NOTICES

To all A.R.R.L. Members residing in the Sections listed below: (The list gives the Sections, closing date for receipt of nominating petitions for Section Manager, the name of the present incumbent and the date of expiration of his term of office.) This notice supersedes previous notices.

In cases where no valid nominating petitions have been received from A.R.R.L. members residing in the different Sections in response to our previous notices, the closing dates for receipt of nominating petitions are set ahead to the dates given herewith. In the absence of nominating petitions from Members of a Section, the incumbent continues to hold his official position and carry on the work of the Section subject, of course, to the filing of proper nominating petitions and the holding of an election by ballot or as may be necessary. Petitions must be in Hartford on or before noon of the dates specified.

Section	Closing Date	Present SCM	Present Term of Office Ends
Western Fla.	Mar. 10, 1937	Edward J. Collins	Mar. 21, 1937
Sacramento Valley	Apr. 1, 1937	George L. Woodington	Apr. 15, 1937
San Francisco	Apr. 15, 1937	Alan D. Whittaker, Jr.	Jan. 18, 1937
Idaho	Apr. 15, 1937	Nellie Hart	Mar. 1, 1937
Gal.-S. C.-Cuba	Apr. 15, 1937	Bannie L. Stewart	Dec. 14, 1936
I. of P. - P. R. - V. I.			
Oklahoma	Apr. 15, 1937	Carter L. Simpson	Feb. 15, 1936
Indiana	Apr. 15, 1937	Arthur L. Braun	July 19, 1936
So. New Jersey	May 3, 1937	Carrol D. Kentner	May 8, 1937
Maine	May 17, 1937	John W. Singleton	May 25, 1937
Maritime*	June 1, 1937	Arthur M. Crowell	June 14, 1937
North Dakota	June 1, 1937	Hartwell B. Burner	June 14, 1937
Nevada	June 1, 1937	Edward W. Heim	June 14, 1937
West Virginia	July 1, 1937	Dr. Wm. H. Rheldaffer	July 12, 1937
Md.-Del.-D. C.	July 1, 1937	Edgar L. Hudson	July 15, 1937
Arizona	July 15, 1937	C. C. Day	July 24, 1937

*In Canadian Sections nominating petitions for Section Managers must be addressed to Canadian General Manager, Alex Reid, 169 Logan Ave., St. Lambert, Quebec. To be valid such petitions must be filed with him on or before the closing dates named.

1. You are hereby notified that an election for an A.R.R.L. Section Communications Manager for the next two year term of office is about to be held in each of these Sections in accordance with the provisions of By-Laws 5, 6, 7, and 8.

2. The elections will take place in the different Sections immediately after the closing date for receipt of nominating petitions as given opposite the different Sections. The ballots mailed from Headquarters will list the names of all eligible candidates nominated for the position by A.R.R.L. members residing in the Sections concerned. Ballots will be mailed to members as of the closing dates specified above, for receipt of nominating petitions.

3. Nominating petitions from the Sections named are hereby solicited. Five or more A.R.R.L. members residing in any Section have the privilege of nominating any member of the League

OBSERVERS' HONOR ROLL

Cairo Commercial Occupancy Survey
For February 1937

6000-8000 kcs.

Walter Lassak

21,000-21,900 kcs.

René Allard, R357 W8APQ W. R. Faries

as candidate for Section Manager. The following form for nomination is suggested:

(Place and date)

Communications Manager, A.R.R.L.

38 La Salle Road, West Hartford, Conn.

We, the undersigned members of the A.R.R.L. residing in the Section of the Division hereby nominate as candidate for Section Communications Manager for this Section for the next two-year term of office.

(Five or more signatures of A.R.R.L. members are required.)

The candidates and five or more signers must be League members in good standing on the petition will be thrown out as invalid. The complete name, address, and station call of the candidate should be included. All such petitions must be filed at the headquarters office of the League in West Hartford, Conn., by noon of the closing date given for receipt of nominating petitions. There is no limit to the number of petitions that may be filed, but no members shall sign more than one.

4. Members are urged to take initiative immediately, filing petitions for the officials for each Section listed above. This is your opportunity to put the man of your choice in office to carry on the work of the organization in your Section.

—F. E. Handy, Communications Manager

ELECTION RESULTS

Valid petitions nominating a single candidate as Section Manager were filed in a number of Sections, as provided in our Constitution and By-Laws, electing the following officials, the term of office starting on the date given.

Mantoba	A. J. R. Stimpson, VE4BG	Feb. 15, 1937
Northern New Jersey	Fred C. Reed, W2GMM	Feb. 15, 1937
Hawaii	Otto Hill, KG4AJ	Feb. 15, 1937
Arkansas	H. E. Velte, W5ABI	Feb. 15, 1937
Western Florida	Apr. 15, 1937 Edw. J. Collins	Mar. 21, 1937

In the Louisiana Section of the Delta Division Mr. Eugene H. Treadaway, W6DKR, and Mr. Cortlandt McCoy, W6DXL, were nominated. Mr. Treadaway received 53 votes and Mr. McCoy received 21 votes. Mr. Treadaway's term of office began Jan. 14, 1937.

STATION ACTIVITIES

CANADA

MARITIME DIVISION

MARITIME—SCM, A. M. Crowell, VE1DQ—HH reports Maritime Net drill 6:45 P.M. daily; traffic is moving smoothly and all net members are signing up with the A.E.C. Net members are HH, HJ, GK, GU, BZ and EY. HJ, in addition to net duties as Halifax Terminal Station, keeps Sunday schedules with VO1W and EI8B on 3.5 Mc. GK now has an SW3 receiver. AP has the 'phone working FB now. BD works 'phone on 3.5 and 14 Mc. AC is still working on his rig. CW makes his 7-Mc. outfit go places with low power. JG is QRL broadcast work. BE is going to rebuild. FR, a low-power man, gets out well. KL with P.P. '45's on 3.5 Mc. hopes soon to be crystal-controlled. BV is back with the new rig using an 804 final, 'phone and c.w. on 3.5 and 14 Mc. CB is going strong with the ole 211D. JF is QRL service work. KW is the new Halifax man on 3.5 and 7 Mc. EV sends Moncton report via the T.L. CF and XYL were visitors at M.A.R.C. meeting held at the home of GI. EV has new Class "B" '46's. CX is still experimenting. JU is completing a 6L6 crystal oscillator. FI is rebuilding to high power. DC has the new 28-Mc. rig going places. GI gets reports on his 3.5-Mc. signals from Ireland. CF recently visited DC. KO gets out well with '46's in parallel. IJ and DI are combining gear to go high power with remote control. IL, a 7-Mc. man, was recently a visitor to Moncton. BJ schedules HH daily. BZ is working on portable 'phone rig for summer. BL is active on 7 and 14 Mc. CO is working all bands with 6L6 osc. and doubler. EO, using 6 watts from Portuguese Cone powered by dynamotor and "Little Joe" gas engine, works real DX on 14-Mc. 'phone. BH has been doing some nice duplex 'phone work with friends in Newfoundland via VO1I. EQ is getting a 'Phone Net organized and wants reliable Halifax station on 3.9 Mc. The Clubroom Committee of the H.A.R.C. now have the rooms at the Y.M.C.A. in fine shape and plans are going ahead for the installing of club transmitter and receiver. AW has the new 805's doing their stuff on 14-Mc. 'phone. AQ has been scheduling KK portable in Labrador (Belle Isle). FO has returned to the air via 3.9-Mc. 'phone. GR made the 14-Mc. 'phone band again with the new rig. ET rebuilt to steel rack and panel and works plenty of DX on 14 Mc. The S.C.M. has been keeping daily schedules with VE5TU and IKK (Nottingham Island and Belle Isle), handling notes of interest to families of the ops and having

friends and XYL's talk to them when conditions permit good signals at both ends. Newfoundland News (via VO1W): VO1B and VO1D expect to be on soon with brand-new rigs. VO1G will be on again soon. VO1H is still experimenting with portables. VO1I and VO1J are active as ever on 14-Mc. 'phone. VO1K is on with a 6L6. VO1M is going places on 3.5 Mc. with his 70 watts. VO1N is heard on 28 and 14 Mc. VO1O is building 6L6 osc. and pair 6L6's final. VO1P is active on 3.5, 7 and 14 Mc. VO1S is active over VO1I on 'phone. VO1U is heard occasionally on 3.5 Mc. VO1W is active on 3.5 and 7 Mc. VO1X is going places with his 6L6. VO2Z is sure having fun with his new rig. VO3F is active on 7 and 14 Mc. with pair of '45's P.P., 30 watts input—power from genemotor, receiver SW3. VO3O is still active on 3.5 Mc. VO3P is active on 3.5 and 7 Mc., single '10. VO3Y is new ham at Conche. Active: VO4Y, VO4C, VO4K. VO3X has new rig: 89 crystal and 807 with 20 watts; he is active on 28, 14, 7 and 3.5 Mc. "VO1" Club is coming along fine, meetings every Monday night at houses of different hams, and at 10 p.m. the rig at the QTH where meeting is held goes on 3.5 Mc. to hook up the outside hams—VO4Y, VO2Z, VO3X, VO3P, VO3O, VO3Y, VO4C, VO4K.

Traffic: VE1HH 93 HJ 107 GK 60 BJ 18 EY 15 EQ-KL 10 EV 14. VO1W 3.

ONTARIO DIVISION

ONTARIO—SCM, Fred H. B. Saxon, VE3SG—R.M.'s: ABW, DU, GT, MB, QK, TM, WK, WX. P.A.M.: NX. IL has been a "Roof Ward" patient in Christie Street Military Hospital almost continuously since war days; the engineers at CRCT have completed a new rig for him, 53 osc.-doubler and '10 final; he is on 14 Mc. most of the time and loves a rag-chew. YY has 14-Mc. grid-modulated 'phone with an 825 in final. AIV is rebuilding for all-band operation. ALT (Kirkland Lake) is in hospital in Toronto recovering from major operation. GG was only in Toronto four days when he was laid up with pneumonia; very glad to report he is progressing nicely. ABW took his receiver over to GG's one evening while Mike was convalescent and 2DG sent "blind" to GG for over half an hour. Still another one—AHA writes in from bed in hospital in Dryden while waiting for operation for goitre. Good luck, Frank, and may you soon be well again. WN has pair of RK-20's in 14-Mc. 'phone band. KG has a 2A5 crystal osc. well trained. ABC has changed TNT '45's to P.P. crystal 53's. FY is having a hard time running an a.c. generator from a washing-machine engine. YB has homemade gas-driven generator working FB. NA has 59 e.c. osc. 59 buffer and '46's final, and reports working a W5 in Texas who had a 19 TNT with 2 watts. VS is building for 1.75-Mc. 'phone with 211's in final. TS is on 1.75-Mc. 'phone. DU reports working D4XJF and PAQCE during a lunch hour. VN is on 7 and 14 Mc. with an RK-20 tri-tet and '03A final. AFR needs Asia for W.A.C. ALU is on 7 and 3.5 Mc. with a '46 final. AGM is looking for an R.C.C. ticket; he is on 3525, 3707 and 7050 kc. GB and GS up at the Lakehead Cities are on 56 Mc. UA is rebuilding. AEP has c.c. rig at Pickle Crow. The Lakehead Club has moved into new quarters with UE supplying the club station. MY has new super. AJV (Frontier Radio Club) has new rig ready to go. AHN has unlimited 'phone ticket. Some of the Niagara gang have regular visits from 8MEX and 8OQB. ABZ is on 3.9-Mc. 'phone with 20 watts. ZS has 2A5 crystal osc. SN has new rig, 53-2A3-P.P. '10's on c.w. AMY is new in Preston. MB is still having trouble with rig and bad line voltage. NC is now using 'T55's in final in place of 800's. Bud does the operating at HV while his dad, Dick, builds up emergency rig for A.E. Corps. SG took schedules for WK while a burnt-out transformer was being replaced. VD qualified for his W.A.C. ticket by contact with VU2AG on 7 Mc. AJM is now building a superhet, having finished his analyzer. LI tried to fight it out with his 1500-volt supply and got licked; he got a couple of burns and lost a pair of '66's before he finally got loose. BEWARE OF HIGH VOLTAGE. PL built up 56-Mc. rig for ski races at Ottawa. FP is building with a pair of 250TH's in final. PG is on 56 Mc. The Hamilton gang gave GZ a double-button mike for a birthday present. TO reports for the Beamsville gang. 9AL has separate rig

on 28 Mc. going FB. OR has a fine signal. NG is now on 3.9-Mc. 'phone. The gang scramble over one another to work "Edna" at FK. KM is QRL with new daughter. WV has job in Toronto. KR is doing things and going places on 14 Mc. ZV changed over to 'phone. AP is back after a long "rest."

Traffic: VE3ABW 164 HV 97 WK 93 AGM 59 SG 57 QK 45 FW 42 DU 39 SS 37 OI 27 ZE 23 GT 22 AHK 16 VD 13 YF 8 NC 5 AE-PL-AU 3 ACI-MB 2. VE9AL 17.

QUEBEC DIVISION

QUEBEC—SCM, Stan Comach, VE2EE—The C.G.M. and your S.C.M. desire to express thanks and appreciation to those who so kindly fell in with the spirit of our broadcast and suspended all operation on the frequencies below 4000 kc. during the period of stress which our friends across the line so lately endured. BU made a trip to Boston to see the family off on a cruise and slipped down to Hartford for a week-end with WIGKM. BG has built a new speech amplifier using metal tubes. JK is now a full-fledged 'phone man. EW is back on the air with plenty of power. DM is rebuilding into a new rack. EX now uses a crystal mike. DC lost half of his gear in a fire in the transmitter. JK, AH, HP, EU, IN, DR, BK, FS and IO were assisting the Dept. of Marine in their tests with the Electro-Therapeutic Generators. The Montreal Radio Club held its annual hamfest around the end of January; attendance was 95 and everyone enjoyed the evening. ER with his 7 watts has added a G and a PY to his list of 'phone contacts. LJ is getting out nicely. HP has completed his pre-selector for the FBXA. AH has resigned the post of QSL Manager; DR has stepped into the breach. Your S.C.M. spent quite a time in Drummondville and visited AA. DD is again working in Montreal. LV is to be congratulated on a baby girl. FB, Mr. Mayor, FO is back on his old frequency. MM's father passed on; condolences. OM. ID is having trouble with his Class A modulators. HE has been working DX on 14 Mc. JK has at last worked New Mexico for his W.A.S. HH is the first VE2 to join the Rag Chewers Club. IN is building a low-power modulator. DR and EE are both using T-20's in place of the ole tens. GK is on a ship plying between Florida and Nassau. The YL at DA is a very active operator on 3.5 Mc. DR lost his antenna mysteriously one evening, clicks Bill! KM is building a frequency meter-monitor with all the trimmings.

Traffic: VE2HH 10 EE 16 IN 3 BU 31 DR 29 EC 26 HT 39 LC 15 KM 6 DG 223 JK 37.

VANALTA DIVISION

ALBERTA—SCM, Alfred D. Kettenbach, VE4LX—PH received his W.A.C. certificate, the first one in Edmonton. IZ has a '52. LQ is using centre-fed Zepp. The Alberta Provincial Net is working FB on spot frequency. The Northern Alberta Radio Club is going full blast; 25 to 30 members turn out for each meeting. XF and HS are new calls in Edmonton. HS came up from Calgary and keeps 3.5 Mc. busy. GT is back on the air; he worked a PY on 14 Mc. AES from Irma visited Edmonton Radio Club; he is using 802 crystal. HM is on 28 Mc. and keeps daily schedule with 5FG. BW moved rig down to store; he has FB antenna 130 feet above ground on top of McLeod Building. ADW gets FB reports on 14 Mc. AEH popped another crystal. MR keeps his 35 watts of QRM on 7 Mc. VJ finds 28-Mc. FB for local QSO after band goes dead for outside points. AAS is on 7 and 3.5 Mc. consistently. XD worked an ES4. ADZ uses e.c. osc.; he keeps schedule with 3 ZU's daily. ADD is trying for South American for W.A.C. HT works DX consistently on 14 Mc. Monthly meeting of Northern Alberta Radio Club was held Feb. 13th; they discussed the Alberta Hamfest, which will be held in Edmonton this year July 10th-11th; they request all hams who can possibly make the hamfest to keep the week-end of July 10th-11th open; come and bring XYL's, YL's and families; meeting finished with a very FB talk and demonstration on the Oscilloscope by BW.

Traffic: VE4LX 59 LQ 41 GE 33 WX 31 SW 13 QK 10 CT 5.

BRITISH COLUMBIA—SCM, D. R. Vaughan-Smith, VE5EP—We take pleasure in welcoming The Trail-Ross-

land Amateur Club as an active B.C. association; officers: pres., 5RL; vice-pres., 5AA, and secy.-treas., 5HX. The Victoria Short Wave Club held its annual banquet at the Hotel Douglas. The Royal City A.R.A. relected Fred Taylor pres., 5II vice-pres., and W. J. Halliday secy.-treas. The Collingwood boys recently entertained a dozen of the Royal City boys, and what a night! The B.C.A.R.A. has its 53-53-RK-20 rig going FB and plans operating contests for the members. GR of Creston did good work during the recent floods. SJ's transmitter refuses to perk on anything; but 7 Mc. MT at last got his signal into England! PJ announces a QSY to Vancouver. KT and NM have been having fun on 56 Mc. DL once again puts a watt or two into the sky hook. FT spent couple of weeks in Vancouver and got a slant on some real rigs. HW is building an oscilloscope for the benefit of the Vernon gang! MJ is the chief link Vernon has with civilization! SO threatens to modulate his tens. SC is getting good results with 6L6 rig. NG coaxed her boy friend into building her a 6A6-RK-23 rig with band-switching. DD, BJ, ON, HU and FG keep things together when the wires go down. RS has fun blowing 6L6's by the hour. AL spends all his spare time taking traffic from the east and hands in a nice total. EO is very proud of his new band-switching rig with 35-T final. GF is really on the air now, 'cause we worked him and we know. CT claims he is on, too! BQ operates special rig on 1.75 Mc. in addition to his 3.9-Mc. transmitter. AV works into the Island Net three times a week. AC is holding up western end of Trunk Line "L." OK gets our vote as most consistent schedule man; he's O.R.S., too.

Traffic: VE5AC 62 AL 88 OK 35 PI 6 CC 13 NG 3 EP 27 FG 35

PRAIRIE DIVISION

MANITOBA—SCM, A. J. R. Simpson, VE4BG—GC reports activity in full swing once again on the Trunk Line. Please report your traffic, gang. Winnipeg lost two well-known hams recently when MW and UX took operating posts in the North country for the airway companies. We are sorry to lose Harry and Bill and wish them every success in their new activity. AE is pleased with his P.P. T55 final. BQ has returned to his operating post in Northern Manitoba. DU keeps up with the DX. ECK completed a 6L6G exciter unit. GL has been trying 3.5 Mc. GQ acquired an RK-20 to use as driver for high-powered final. IP is about ready to put on his Class B RK-20's. KX has been trying a 250TH for ZK. ZK made a one-month visit to San Antonio and finds the W5's a good bunch. LH has P.P. 50-watt final on 14 Mc. with 6L6 modulators. MY is heard on at new QTH. OK holds the record for consistent operation on 56 Mc. QC is thinking of installing a 6L6 exciter for the T55. QF has gone high power with an 860 final. RO has his T155 difficulties cleared up. TJ has an FB 14-Mc. 'phone signal. SS is looking for transformers to run his high-power Class B modulator. ZU and QI spend their time on 28 Mc. SR replaced his '10's with a pair of T20's. AC from Brandon was a visitor to Winnipeg on his return from a two months' vacation in California. OC relayed a call from AEB of an emergency nature.

Traffic: VE4GC 33 WAW 36.

SASKATCHEWAN—SCM, Wilfred Skaife, VE4EL—UG needs only Asia for W.A.C. UH is rebuilding to use three 6L6's. MB reports FB time in L.A. visiting hams and gathering ideas. SP, IQ and AFS are new calls in Saskatoon. TW lights neon bulb on any metal anywhere in the shack. QZ is receiving European reports on his 14- and 28-Mc. sigs; he is now running 6L6 crystal osc. on 3.5 and 7 Mc. XB stays with 7 Mc. FQ snagged Cuba to add to his list of countries. BF and UD are getting good results on 28-Mc. 'phone. UD made 68 contacts in 7 days on 28 Mc. RJ finds high noise level at his new QTH. JB has new super and new rig. The local net for handling traffic now comprises UL, PG, PQ, QZ, ACR and KJ feeding trunk line work to FW. Contact them for and feed them with traffic. OW and ABB return to the air after long illnesses. YC, GA and FA are in a huddle as usual. UL and YC use break-in. YC has three rigs to cover all bands, one rig battery power for emergency work. ABS and XM are trying 28-Mc. 'phone. AFO visited and enjoyed QSO's at EL.

Traffic: VE4PQ 43 QZ 12 PG 10 UD 5 UL 6 EL 6 YC 2

(Continued on page 100)



CORRESPONDENCE

The Publishers of QST assume no responsibility for statements made herein by correspondents

Emergency Frequency

2018 Sul Ross Ave., Houston, Texas

Editor, QST:

As I sit this evening in the den . . . I find it very difficult to put into words the thoughts which run through my mind, as I try to visualize . . . vivid pictures painted . . . by Paul Sullivan, dynamic news commentator who broadcasts nightly over WLW, the principal topic of his broadcast of but a few moments ago being the deplorable condition of . . . the broad Ohio River Valley. . . .

The position of the amateur in such instances is traditional. But all too often great difficulty is experienced by amateurs operating low-powered, inadequate emergency equipment, due not only to the insufficiency of their available equipment and power supply but also to the severe QRM situation existing in many important localities, where stations of the greatest value would be located.

I feel greatly my inadequacy to cope with the vastness of the entire situation, with its extensive ramifications, but from my single viewpoint alone I suggest:

Let there be reserved by extensive internal campaigning and subsequent mutual agreement, a space not to exceed five kilocycles on the edge of each radiotelephone band, to be used by neither telephone nor telegraph stations, but to be used as an emergency frequency. Amateurs so desiring could purchase or obtain crystals to operate on this frequency, but the great majority could and would rely upon the fact that all that would be necessary to occupy that frequency would be very minor, if any, circuit changes in the oscillator, and the retuning of the transmitter. Let there also be set aside a space not to exceed three kilocycles in some territory of the forty-meter exclusive telegraph band. These frequencies would be so placed that the effect would be one of a constant watch upon them. Let there also be an agreement that if possible (i.e., if not engaged in communication at the moment) while operating the receiver, each amateur would adopt the commercial policy (nay, regulation) of listening on the distress frequency from 15 to 18 minutes past the hour and from 45 to 48 minutes past the hour.

A typical example of these frequency reservations in the amateur bands would be:

From 1800 to	1805 kc.
3900	3905
7150	7153
14150	14155

It is a well known fact that much emergency work of sterling character is spoiled by the negligence or misunderstanding of amateur operators whose transmitters occupy the distress frequency in use by the emergency station. The plan of policing the band is only partially effective. After all, as has been pointed out many times before, the chief, if not the only reason for allowing the amateur generous slices of territory which he occupies in the radio spectrum, is his ability for public service.

In this light, does this plan sound exorbitant or unreasonable? What are five kilocycles of space and the gracious habit of listening six minutes each hour when weighed against the value of time and lives in emergencies of this sort, and checked in the 72-point banner headlines of the nation's press, under the severe eye of public opinion and good will?

—Luther C. Smith, Jr., W5E00

F.C.C. Ban

30 Brookwood Dr., Maplewood, N. J.

Editor, QST:

The action of the F.C.C. in prohibiting general communication on 3.5-4 and 1.7-2 Mc. during the flood disaster of recent date should awaken those members of our fraternity who have little or no commonsense to the idea of coöperation on our congested bands, especially when an emergency in which amateur radio can be of great assistance presents itself. To any broad-minded person, the order of January 26th was a "slap in the face" to ham radio. Why could not the operator themselves realize that by standing by, the channels would be cleared to allow the signals from battery-powered rigs in the flood area to get through?

While monitoring on 160 meters, I was highly disappointed to note the vast number of stations on calling "CQ Flood Traffic." If the operators of these stations had rather sat back and waited for a "CQ" from the flood area, they would have been of greater service.

Beyond a doubt, many of my remarks are rather severe, but they are my sincerest senti-

ments. In accordance with my feelings are Les Baglee, W2JMX of Roselle Park, N. J., and Lou Matos, W2HZR of East Orange, N. J.

—William H. Zilliox, Jr., W4HFB

Editor's Note.—No "slap in the face" to amateurs in the flooded area battling ruinous QRM was the F.C.C. ban, which effectually voided practically all serious interference difficulty. They regard it as, in fact, official recognition of the invaluable and indispensable nature of the work they were performing, and are loudly unanimous in its praise.

Testing Transmitting Tubes

Harrison, N. J.

Editor, QST:

QST for January, 1937, contains an article on page 47 entitled "Testing Transmitting Tubes" which outlines a method of checking the electron emission of doubtful transmitting tubes. The method consists of measuring the plate current of the tube and comparing the results with values obtained from published plate characteristic curves. It is inferred that a tube giving a plate current below the published value has low emission. The purpose of this letter is to point out that this method can give results of value only in the case of extremely low emission.

Consider the example given in the article. The test on the 860 is made at a plate current of 100 ma. Now the normal emission of an 860 is about 3 amperes. A tube with only 1 ampere emission would certainly be "low emission" but, for the above example, the emission would still be 10 times the amount required for the test, consequently the plate current would still be very near the normal value for that tube. If the emission were down to 50 ma. i.e., 1/60 of normal, then, of course, the normal value of plate current could not be obtained. However, a brief test in the transmitter would immediately show such a tube to be unusable.

Furthermore, tubes do differ somewhat in plate current from the published value even though the filament emission is high. This is so because the plate current is affected by slight variations in the dimensions and symmetry of the electrodes. Thus, if tests are made as described in the article, a good tube might be discarded because its plate current was somewhat below normal.

It is well to point out that no attempt should be made to measure the full emission of transmitting tubes directly as this emission, in general, is so high that the resulting dissipation in the tube would very likely destroy the tube. Full emission measurements require elaborate and expensive equipment. . . .

—E. E. Spitzer,

Research & Development Laboratory

Dixie Burns

1102 N. Walnut, Hutchinson, Kans.

Editor, QST:

. . . Isn't there some way we can get "Dixie Jones" in the newspapers and on the radio in place of Bob Burns? Anyone who can write like that, spell like that, and who probably already has a swell southern accent, should just about lay Burns in the shade. I like Burns, but his bunch of aged jokes weary me now and then. To me, the "Squinch Owl" stuff is the best substitute for Will Rogers so far. . . .

—Margaret Hill
(Mrs. Gordon Hill)

Editor's Note.—Keeping the identity of Mrs. Hill—who, by the way, has read QST consistently for eight years but has no license or transmitter!—a dark secret, a copy of this letter was sent to Dixie Will Rogers S.O. Burns-Jones. The result:

"I bet you a dollar and six bits agin a pipefull of rabbit tobacco that that there letter you speak of was from Letha and what she says about me don't count on account of because she loves me and everybody nose that the eyes of love sees virtues that ain't there. There is some forty nine 1000

other readers of QST that ain't affected in that manner and you never heered a cheep out of any of them, did you? Naw, they can take thair Owl Juice or leave it alone and it don't make no diff.

"The trouble with Letha besides what I said is that she was borned and brung up right there in them Ozarks and she's heered them jokes that Bob Burns is atellin' ever sense she was gnee high to a grasshopper and they ain't funny no more, and furthermore they never was, as they hold her loved ones up to ridicule. Mine too. I come from up that-away myself and it makes my purty dang mad for snooty city folks all over everwhere to be a haw-hawin' over, for instance, Bob Burns' joke about his Uncle Eb (whitch might just as well be about my uncle Jeremiah Barnhill) a sleepin' in his underwear when anybody nose there ain't no steam heat in the country and when it's cold a feller's got to have sumpn on under the kivver. He can't sleep plumb raw without ketchin' a misery.

"That there Ozark country is a mighty healthy place to live. Mountain streams run clear as crystal and mountain air is clean and pure and mountain gals are the best there is. Folks up there don't never die. They just dry up, in time, and blow away. I'll tell you a true story about my Uncle Jeremiah. One day a Yankee gentleman was ridin' along through there and he comes to my Uncle Jerry a settin' on a stump by the side of the road a cryin'. Uncle Jerry at the time has long white whiskers and is bald headed and is about 80 years old and he's a cryin'. The stranger stops his hoss and says: 'Whatcha crying about, old man?' Uncle Jerry looks up through the tears and says: 'Pappy whooped me.' The stranger says: 'What did he whip you for?' And Uncle Jerry says: 'Fer sassin' grandpappy.'

"You oughta move outa that turrible country where you're at, Clint, and go to the Ozarks where you may not have so much fun all at once but you have what you have a lot longer.

"Dixie Jones, W4IR"

D.C. Valve Without C.?

522 Belleforte Ave., Oak Park, Ill.

Editor, QST:

I read with interest Mr. Kunits' article on the static-type velocity microphone. As a result I wish to start an argument on a theoretical point.

To me it appears that no mathematics is needed to demonstrate that the microphone as shown can not act as a valve which controls the power available from the d.c. supply. Neglecting leakage currents, which are supposed not to be necessary, no direct current is drawn from the d.c. source, therefore no power from the d.c. source and consequently no valve or relay action.

—G. D. Robinson

QST for High-Pass Finals

609 S. Fourth St., Champaign, Ill.

Editor, QST:

Here is one time that amateur radio and QST aided rather than hindered a "pore student." Struggling at the U. of I. here, W9TDM of DuQuoin, Ill., was faced with two very disheartening final exams and an hour or two to kill between them. Being a very industrious (?) individual he took the latest QST with him to class to read between exams. After the first exam papers were handed out to the victims, the Prof started patrolling the room and spied the QST parked on TDM's desk.

"Do you mind if I read this while you finish your exam paper?" he asked.

Of course TDM replied, "No, certainly not."

After which the Prof returned to his own desk and proceeded to bury his puss between the covers of dear old QST. Meantime the class took advantage of the heaven-sent opportunity, and the old reliable "grapevine telegraph" started functioning: It is rumored that the whole class passed the exam.

(Continued on page 68)

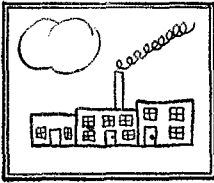

RECENTLY 9LD paid us a visit, and in the course of touring the plant expressed surprise that we actually did have a factory. We were somewhat taken aback by his remark, as we had always assumed that our customers knew that we had one. On pondering what he had said we were struck by the surprising fact that there actually are only two American factories (National's and Hammarlund's) devoted exclusively to the complete manufacture of communication equipment. With the exception of the big companies with whom amateur radio is an interesting sideline, all the other manufacturers are really assemblers who buy broadcast receiver parts and adapt them as well as may be to the requirements of amateur communication work.

As we have no desire to be classed among the assemblers, we are going to celebrate the beginning of the third year of this series by talking a little about ourselves. Be advised then, that we have the sort of a factory that a man can take pride in, and that in this plant we make nearly all the parts that go into our receivers. Our equipment is as diversified as our products, and ranges from bakelite molding presses to signal generators, and from universal winding machines to back geared presses large enough to blank out an NC100 chassis at a single blow.

It is, we think, rather unusual for a company of our size to indulge in so many different manufacturing techniques. But by doing so, we remove both the necessity and the desire for compromise. When we need a tuning condenser for a receiver like the HRO, we do not need to search the market for a broadcast model that is adaptable to high frequency use. Instead, we design the PW condenser with single-minded attention to low losses at high frequencies and permanence of calibration. After which, by controlling every step in its manufacture, we make sure that the materials and workmanship are all that we claim them to be. All this costs a lot of money, of course. We could buy a pretty good condenser for a lot less than it costs us to build the PW, and it would do the job nearly as well. However, "pretty good" is nowhere near good enough when you are setting the pace. Only by building every part to the highest possible standards can you arrive at a receiver like the HRO. In short, we build all these different parts simply because we do not know how else to get them.

Also by way of celebrating the anniversary of this page, we wish to say a little about the men who sell our products. Both individually and as a group they represent the highest standards of honor in all their dealings. They have other qualifications of course. All have the ability, the equipment, and the experience to serve the amateur wisely and well.

The very high reputation which these dealers enjoy has proved to be an irresistible temptation to a few traders, unfortunately. The methods used to horn in on this prestige are quite ingenious. Often a few National parts, (obtained by devious methods) are displayed along with ambiguous advertising that implies they have a National franchise. This sort of thing is very hard to prevent, so look for the sign, "Authorized National Distributor."

One thing more. In justice to a number of very fine dealers who do not sell National products, an explanation is in order. In some of the large cities, there are groups of dealers located so close together that the competition is too close for comfort. Often all of these dealers set high standards, yet only one has the National franchise. The reason is that the one dealer is an old friend. Often he has sold our products for close to a quarter century, and we are rewarding his loyalty to us with an exclusive franchise.

JAMES MILLEN



Check THESE POINTS BEFORE YOU BUY YOUR NEXT CRYSTAL

POWER

Has it been fully tested in a loaded oscillator? Each Bliley Crystal is checked in a special oscillator which readily reveals its power capabilities.

ACTIVITY

Has it been ground for maximum activity? Every Bliley Crystal must accurately follow rapid keying in a loaded oscillator.

CALIBRATION

Can you depend upon its calibrated frequency? All Bliley Crystals are measured against a primary standard of frequency, accurate to 2 parts in 10 million.

OVERLOAD

Will it stand up under adverse operating conditions? Bliley Crystals are subjected to an overload test to insure complete reliability.

BLILEY ELECTRIC CO., ERIE, PA.

FOR BETTER
CRYSTAL CONTROL

Correspondence

(Continued from page 68)

Here's hoping that this will increase your university circulation. HII!

—E. L. Conant, W9GMS

Curing Bad Signals

404 Washington Ave., N. Minneapolis, Minn.

Editor, *QST*:

We may well be proud of the way in which amateur radio, guided by the ever-watchful A.R.R.L., has gone steadily forward. One of the principal reasons for our progress has been, I believe, the unity in our members: the fact that any selfish advantage to an individual or to a group has been sacrificed for the good of the majority.

However, we still have some individuals and groups who are taking selfish advantage, and the offenders are usually the same, month after month. I mean the fellows who are putting out the rough, broad, illegal signals, and who have no intention of doing otherwise. I, for one, think that it is time we quit being goats for those buzz saws, and this is my suggestion for cleaning up our bands:

Let each operator who hears a station using one of those illegal notes report in writing to the League, giving the following information:

1. Call letters of the offending station.
2. What the station was doing (testing, calling, working).
3. Approximate frequency.
4. Date.
5. Local time at reporting station.
6. Type of receiver at reporting station.

Let the League keep these reports in a strictly confidential file until a total of five reports from different parts of the country has been received for one station.

When the total of five reports has been reached, let the League write the offending station, warning the owner that unless the note is made to comply with regulations within ten days, a report will be made to the F.C.C. At the same time, let the League write to the five who reported, advising date of the warning letter, and telling the five to watch for the offending station after ten days from date of the warning letter, and to report the nature of the signal.

The fact that five reports must be received from five different localities would prevent anyone from taking advantage of this procedure to air a personal grievance. The reason for listing the type receiver used by the reporting station is to allow the League to judge whether the receiving equipment is good enough to allow a just complaint.

It seems to me that this sort of action would put a stop to these a.c. galloping, rough signals, as well as to the signals which are "smoothed" by an alleged resonant choke.

—L. A. Morrow, W9VKF

About Religion

Cadis, Ohio

Editor, *QST*:

After reading *QST* from the very first issue, and following with interest the growth of amateur radio, I write for my first time to express an opinion suggested by Rus Sakkers, W8ED, in the February issue regarding the religious status, and possibility of organizing amateurs in a club that would serve as an outlet for what has been called religion.

I don't believe there is necessarily a low average religiously among radio amateurs, but that nothing has been done to encourage a statement of faith of the thousands engaged in the cleanest, and in many senses, the most Christian hobby in the world. Most persons do not talk easily about their deeper convictions. However, the formation of a society or club definitely dedicated to a closer fellowship of all who have abiding religious convictions, would serve to encourage a sharing of this common faith, to the edification of all.

During my twenty-four years in amateur radio, operating from the days of self-assigned calls through legitimate calls 8AWZ, 9QI, 9PM, WBCH, and now W8GTA (a minister moves about, you know), I have QSO'ed with only two

*"I can use These
Controls with*
CONFIDENCE!"

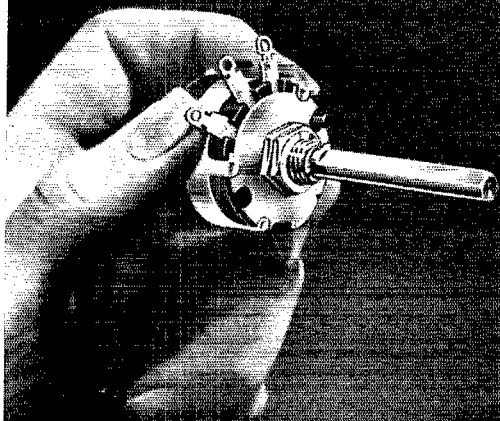

Metallized
**VOLUME
CONTROL**

**• PERMANENT • QUIET •
• RUGGED •**

LOOK IN RIDER'S MANUAL (Index to Volume 7) for complete IRC Volume Control Replacement Guide.

HANDY POCKET-SIZE GUIDE FREE to bonafide servicemen upon request to IRC jobbers.

INTERNATIONAL RESISTANCE COMPANY

401 NORTH BROAD STREET, PHILADELPHIA, PA.

Factories or Licensees in Canada, England, France, Germany, Italy, Denmark and Australia

**MAKERS OF RESISTANCE UNITS OF MORE TYPES, IN MORE SHAPES, FOR
MORE APPLICATIONS THAN ANY OTHER MANUFACTURER IN THE WORLD**

Say You Saw It in *QST* — It Identifies You and Helps *QST*

BASSETT CONCENTRIC FEEDER

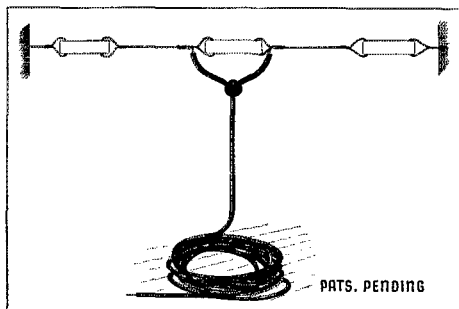

A 100% FLEXIBLE CONCENTRIC TRANSMISSION SYSTEM

with
THESE ADVANTAGES

1. Ease of Installation
 2. Extremely High Efficiency
 3. Absence of Line Radiation
 4. Easily Handles California KW
 5. May be Buried or Submerged in Water
 6. Unaffected by Rain, Snow, Temperature, or Humidity
 7. May be Link, Capacitive, Inductive, or Net Coupled
 8. Attenuation of Harmonics
- AND
9. Lower in Cost

BASSETT RESEARCH CORPORATION

1436 Maccabees Building
Detroit, Michigan

Amateurs may also contact

MIMS RADIO COMPANY
Box 504, Texarkana, Arkansas

OR
YOUR LOCAL DEALERS

Catholic priests, one Methodist minister, and one Lutheran minister. However, I have had definite statements of faith on the part of a large number whom I have contacted, which goes to show that while religion is not well represented by professional religious leaders, I do believe there is, running through and through our ranks, the golden cord of an abiding faith in the great God of the universe. To personify and bring to the surface this faith would be a good thing, both for those who have it, and those who have it not. . . .

I would not be interested in a club that would be confined to any one faith or creed—this could not be. The ranks of amateur radio embraces all faiths and creeds. However, there is the one God, and the one common need that he can and will supply for us all. These are days of definite classification, renewed emphasis. Shall we not reemphasize the God of all good, the God of the electrons, the God of service, by setting aside a "spectrum" in our QSO's for his traffic? If we will do this, I believe we shall feel the grip of the—hands of the silent keys—clasping understandingly, and in a way uniting the seen and the unseen. It has not been my purpose to preach, only to testify and to obligate myself to do whatever I can to bring about such a club. *Domine quo vadis.*

—Rev. C. Lynn White,
First Church of Christ

Watertown, Conn

Editor, QST:

Have just read with interest W8DED's letter suggesting that amateurs interested in religion get together and start a club for mutual spiritual uplift of the members, and for the benefit of fellow amateurs. I wish to register my hearty approval to this suggestion, as it is all too true that in this age of speed and confusion too little attention is paid to the Giver of All Life and His divine purposes for us.

I am not a religious fanatic, but I do know how much religion can help a fellow who is discouraged. What more noble purpose could conscientious amateurs champion than to spread words of cheer and promise to those who are depressed?

We all know that there are all classes and walks of life represented among the amateur ranks. Many of them are ministers who would undoubtedly be willing to lead the way if they were sure that their efforts would be effective. Without doubt, many of the boys have personal experiences in their own lives which have convinced them of the nearness of a Higher Power.

The least those of us who are interested can do, in this day of increasing QRM, is to observe the Golden Rule, and give the other fellow a break.

—Sperry Skilton, W1KKG

De Funiak Spgs., Fla.

Editor, QST:

I just want to say AMEN to article by Rus Sakkers, W8DED.

I think it's high time for us amateurs to give some heavy thought to a Kind Maker and give him some long-delayed thanks for the use of His material which has made possible our present equipment and a hobby that has given so many hams so much pleasure.

So when we think of how much good radio is doing now while a disaster is in the making, and when we work some specially good DX and everything goes nice, let's turn our thoughts to Him like this, "We Thank Thee From Whom All Our Blessings Come." Amen.

—Oscar Cederstrom, W4AXP

Boise, Idaho

Editor, QST:

It is with deepest regret that I noticed the entry of religion into your pages by W8DED. However, it is far better to not say enough than to say too much about such things, so if it eases the boys' minds enough, go to it. I have a S.S. super and can tune to some other frequency, and there are other radio magazines if too much space is taken between your covers.

—H. C. Eichelberger, W7EMT/WLYK

Thoughtfulness

Dresden, Ohio

Editor, QST:

Just about five minutes ago something happened that you should know about and also every one else who is connected

(Continued on page 106)

and NOW
TEMCO
350 and 100
WATT TRANSMITTERS
for Medium Power

350 This transmitter represents Temco's contribution to the medium power classification—*not to a price—but despite this it is well within the means of all.* Features include band switching equipment; simplified tuning control; more than ample excitation available assuring efficient 30 mc operation; remote control from operating position. **R. F. Tubes:** 6L6, RK25, T55, 2-T55's. **A. F. Tubes:** 6J7, 6N7, 2-6C5's, 2-2A3's, 2-T55's. **Frequency range:** 1.5 mc. to 30 mc. **Dimensions:** 66" x 21" x 15".

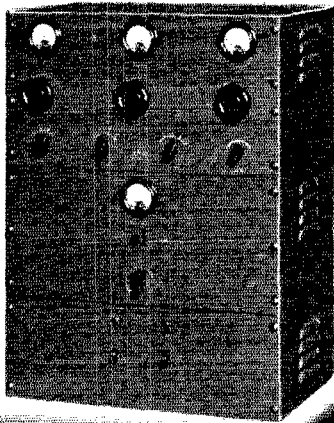
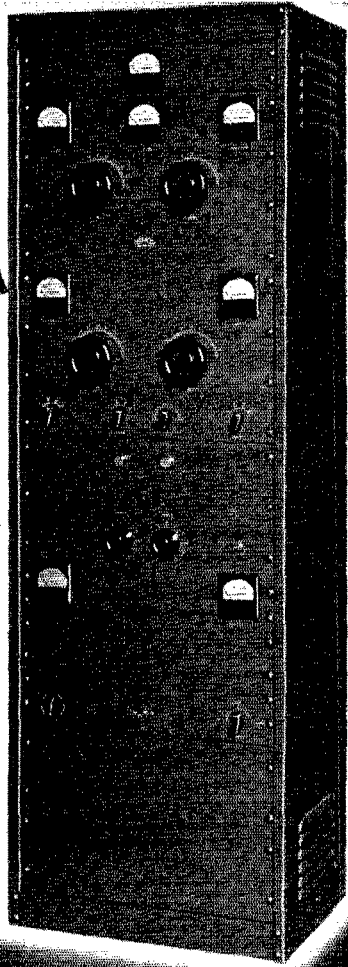

100 Identical in quality and following the same general design as the "350" this transmitter by Temco and needs is a contribution worthy of every consideration from those who want outstanding performance in a lower power unit. The features are the same as the "350". Tube line-up is as follows: **R. F. Tubes:** 6L6, RK25, T55. **A. F. Tubes:** 6F5, 6C5, 6N7, 2-6L6's. **Frequency Range:** 1.5 mc. to 30 mc. **Dimensions:** 36" x 18" x 13".

You are urged to write for complete illustrated technical data sheets for both the Temco "350" and "100" units illustrated here as well as the Temco 600 and 1000 watt transmitters. Address requests for this material to attention W2KX.



Transmitter Equipment Manufacturing Co., INC.

130 CEDAR STREET • NEW YORK, N. Y.

Designers and Manufacturers of Radio Transmitting and Accessory Equipment

Now—a high-powered—

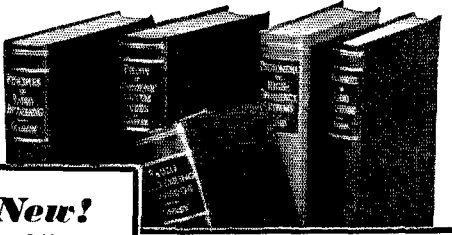

New!

The Library now comprises a revised selection of books culled from latest McGraw-Hill publications in the radio field.

**RADIO
ENGINEERING
LIBRARY**

- especially selected by radio specialists of McGraw-Hill publications
- to give most complete, dependable coverage of facts needed by all whose fields are grounded on radio fundamentals
- available at a special price and terms

These books cover circuit phenomena, tube theory, networks, measurements, and other subjects—give specialized treatment of all fields of practical design and application. They are books of recognized position in the literature—books you will refer to and be referred to often. If you are a researcher or experimenter—if your interest in radio is deep-set and based on a real desire to go further in this field—you want these books for the help they give in hundreds of problems throughout the whole field of radio engineering.

5 volumes, 3064 pages, 2000 illustrations

1. Glasgow's **PRINCIPLES OF RADIO ENGINEERING**
2. Terman's **MEASUREMENTS IN RADIO ENGINEERING**
3. Chaffee's **THEORY OF THERMIONIC VACUUM TUBES**
4. Hund's **PHENOMENA IN HIGH-FREQUENCY SYSTEMS**
5. Henney's **RADIO ENGINEERING HANDBOOK**

Special Low Price and Easy Terms

Bought singly, the five volumes comprising this library would cost you \$25.00. Under this offer you save \$1.50 and, in addition, have the privilege of paying in easy installments beginning with \$2.50, 10 days after receipt of the books, and \$3.00 monthly thereafter. Already these books are recognized as standard works that you are bound to require sooner or later. Take advantage of these convenient terms to add them to your library now.

SEND THIS ON-APPROVAL COUPON

McGraw-Hill Book Co., Inc.
330 W. 42nd St., New York, N. Y.

Send me Radio Engineering Library, 5 vols., for 10 days' examination on approval. In 10 days I will send \$2.50, plus few cents postage, and \$3.00 monthly till \$23.50 is paid, or return books postpaid. (We pay postage on orders accompanied by remittance of first installment.)

Name

Address

City and State

Position

Company QST-4-37

(Books sent on approval in U. S. and Canada only.)

**"In the Public Interest,
Convenience and Necessity"**

(Continued from page #0)

handled largely personal traffic in the Kentucky net, tying in with the A.A.R.S. W9MN also co-operated with the local police.

QH1 was an emergency station flown to Bowman Field, Louisville, from Wright Field, Dayton, to provide communication between the two airports to aid in shipping supplies by air. The operator, Robert J. Neff, being a ham—W8CDR—QH1 was soon in contact with amateur stations and, indeed, handled most of its traffic through them, in the period from 6:00 P.M. to 8:00 A.M. Aided by a locally-recruited stenographic and delivery crew, traffic received on regular schedule with seven amateur stations from January 29th to February 5th.

A goodly number of other Louisville amateurs participated in the emergency work for shorter periods at various stages—their available time in some instances being limited by other emergency duties. One of these was Frank L. Parsons,



KES SCHONERT, W9HQD, HARRISBURG, A KEY STATION IN THE SOUTHERN ILLINOIS EMERGENCY WORK, BASE FOR W9MWC

W9EYW, of the AP, who had to go to another city to help turn out the Louisville *Courier-Journal*. Thereupon W9YQN operated W9EYW until power failed; between them, they handled a quantity of official traffic, especially for the Director of Public Safety, on 4- and 14-Mc. 'phone.

Bernard Holtman, W9VXT, who retained power at all times, worked 4-Mc. 'phone for the Army Engineers, Red Cross and National Guard, aiding in the transportation of food from Knoxville by truck. Darrell V. Downard, W9ARU, relieved by W9HBQ, on Trunk Line "J" and the Kentucky Net, although ill, operated until power went off, then installed an emergency rig at Red Cross Headquarters, Fountaine Ferry Park; however, the National Guard managed to command telephone service at all times. Joseph C. Kuhn, W9HBQ, was also on at his own station, but power and telephone service failed earlier there.



GORDON ISCHE
 one of the outstanding radio dealers of Milwaukee.

"THERE IS ONLY ONE CONTROL - AND THAT'S A Centralab!"

... says **Gordon Ische**

"We do considerable radio repair business with an efficient service department. In many cases it is the Volume Control

that gives trouble ... we replace them with CENTRALABS...the customer is well pleased and we never have a 'kick-back'."

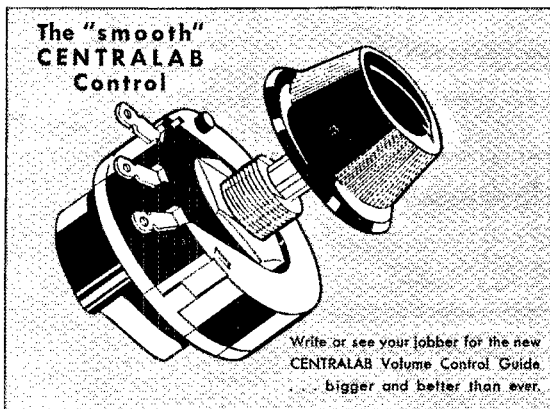

ISCHE BROS. famous store at 5527 W. North Avenue, and famous Electric Neon sign. Headquarters for good radios and good repair service.

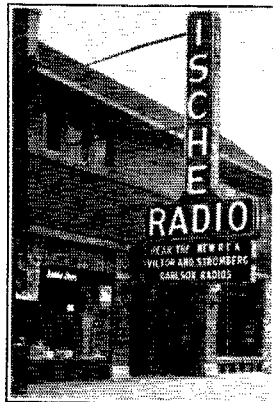

CENTRALAB Division of Globe-Union Inc., Milwaukee
 CANTERBURY ROAD, KILBURN, LONDON N. W. 6, ENGLAND
 118 AVE LEDRU-ROLLIN, PARIS, FRANCE

Centralab *Radiohn*

RADIO SHACK carries a complete stock of the new UTC Beam Power Amplifiers announced in March issue of QST.

Power to spare in the new PAK-6X 250 watt amplifier to modulate a 500 watt transmitter

SPECIFICATIONS: A universal 250 watt output stage. Line to push pull grids input. Varimatch driver transformer . . . Varimatch modulation output to match any RF load . . . Designed for 2-T-203B's driven by 2-6A5G's but will accommodate 42's, 45's, 59's, 2A3's, 6L6's as drivers and 805's, 838's, 203A's, 203H's, 211H's, 830B's, RK31's, 100T's, HF100's, T5's, 822's or similar output tubes at 1250 volt operating condition. Separate power and audio decks. Kit with all accessories less tubes, net price. **\$120**

A REAL HE-MAN BEAM POWER AMPLIFIER

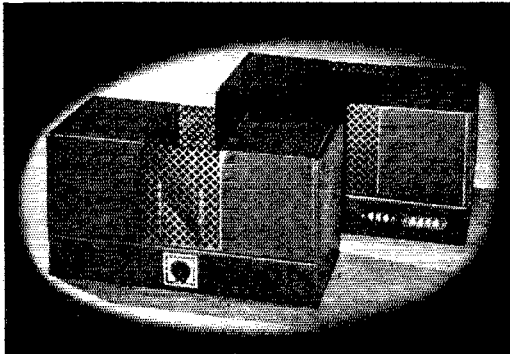

PAK-3X uses four 6L6's . . . 110 watts fixed bias . . . 70 watts self bias. Tubes are 6J7, 6J7, 2-6A5G's, 4-6L6G's, 2-83's . . . Gain 110 DB. Separate chassis for power and audio . . . can be rack mounted. High impedance input, Varimatch modulation output to match any RF load. Kit including all accessories less tubes **\$75**

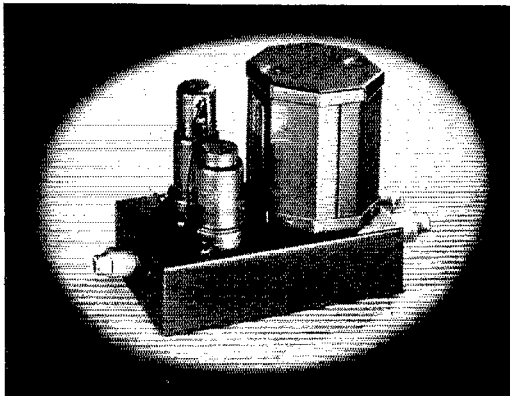

A REMARKABLE VALUE FOR A REAL QUALITY PRE-AMPLIFIER

PAK-7A High gain, well filtered pre-amplifier designed to operate from power supply in main amplifier. High impedance input . . . 6F5 resistance coupled to 6C5 . . . gain 60 DB . . . 50, 200, 500 ohms output-amplifier kit less tubes. Net price **\$9.00**. PAK-7P power supply, if desired, net price. **\$10**

Get our price for the above kits completely wired, laboratory tested and fully calibrated—ready to use

Radio Shack carries the most complete stock of UTC products in New England. It pays to patronize Radio Shack. Along with UTC, the Radio Shack carries authorized electronic and communication apparatus, including Western Electric high frequency tubes, Taylor tubes, Weston meters, Brush devices, I.R.C. resistors . . .

RADIO SHACK
46 BRATTLE STREET . . . BOSTON, MASS.
UNITED TRANSFORMER CORP.

With a 71A on "B" batteries and an O-V-1 with 30's, Louis A. Williams, W9FZV, originated 142, delivered 109, found that inability to make deliveries and overtime as a WHAS operator made it hard to pile up a traffic total! He was one of the 3610 group. Another busy WHAS operator, R. B. Parmenter, W9PLM, at St. Mathews, rigged an emergency transmitter that really got down to elements. It consisted of a Ford spark coil and 6-volt storage battery, circuit *circa* 1907. "The signal was surprisingly sharp," writes a Pittsburgh amateur who took two Red Cross messages. Personal traffic was handled as well, with W9FZV assisting.

W9HXN was constructed in the Armory at Louisville by two commercial operators from New York named Lintz and Petersen. It was built out of an old Army SCR-109 transmitter, with 100 watts to a 211 from dynamotors. Charles J. Elder, W9KBR, at his own station on 3810 until power failure, assisted in operating W9HXN.

Stations active in emergency work in the general vicinity of Louisville include Russell E. Chamberlain, W9KOX/WLHU, of Middletown, Ky. Located on one of the nearest dry spots outside the Louisville city limits, the operators—W9KOX at night, W9SDG during the day—were besieged with traffic, a total of 406 messages being handled on KYN and A.A.R.S. circuits. An emergency battery-powered rig originally prepared to be taken to Carrollton (the job actually handled by W9NKD) found effective use at the outgoing end of cleared telephone lines to the mayor's office and Red Cross in Louisville.

With water three feet deep in their home, husband and wife W9XYW and W9XYN and friends salvaged the radio gear and set it up in the home of a friend. Later, the Kentucky-Tennessee Light & Power Co. offered them facilities at Bloomfield, ten miles from Bardstown, the distributing center for Louisville flood refugees. In these three locations, Betty J. Sams, aided by W9WMH, W9YQO, W9YXW, W9ACD and W9LOL, handled traffic in the Kentucky net and on 7 Mc. for the Red Cross (boats and typhoid vaccine), National Guard and power company. W9MYH was on at Warsaw with four operators, among other things aiding the Michigan State Police planes in flight.

At Fort Knox, Ray B. Gravitt, W9KCZ, held down the Fort on 3992 kc., relieved by W9KYA and W9PVT to the benefit of the Red Cross, Army, National Guard, and C.C.C. The station was operated mainly as a relay point for traffic going up and down the river, notably from Paducah. Also at Fort Knox, Capt. Granville T. Morse, W9THS, operated in conjunction with the Corps Area radio net, handling traffic for the Army post arranging truck detachments, as well as in the A.A.R.S.

The city of Owensboro was mostly high and dry, but it was filled with refugees from nearby points. Active there were W9UKD, the Owensboro Association of Radio Amateurs' station, W9OHH, W9BJW, and W9PKW.

At Henderson, Ky., "the floodless city on the Ohio—high and dry 19 ft. above the 1937 flood,"

RME - 69

Adequate band-spread tuning is essential on crystal controlled receivers. The RME-69 uses electrical means in giving the desired latitude in tuning on our present over-crowded amateur channels.

On the 10, 20, and 40 meter amateur bands, approximately 100 divisions on the scale are normally used. On special order, at no additional cost, this spread may be increased approximately 70%. For all practical purposes, however, the standard spread is entirely adequate.

Good band-spread features are one of the prime essentials to any modern amateur receiver.

Write for Bulletin 69

Radio Mfg. Engineers, Inc.

Peoria, Illinois

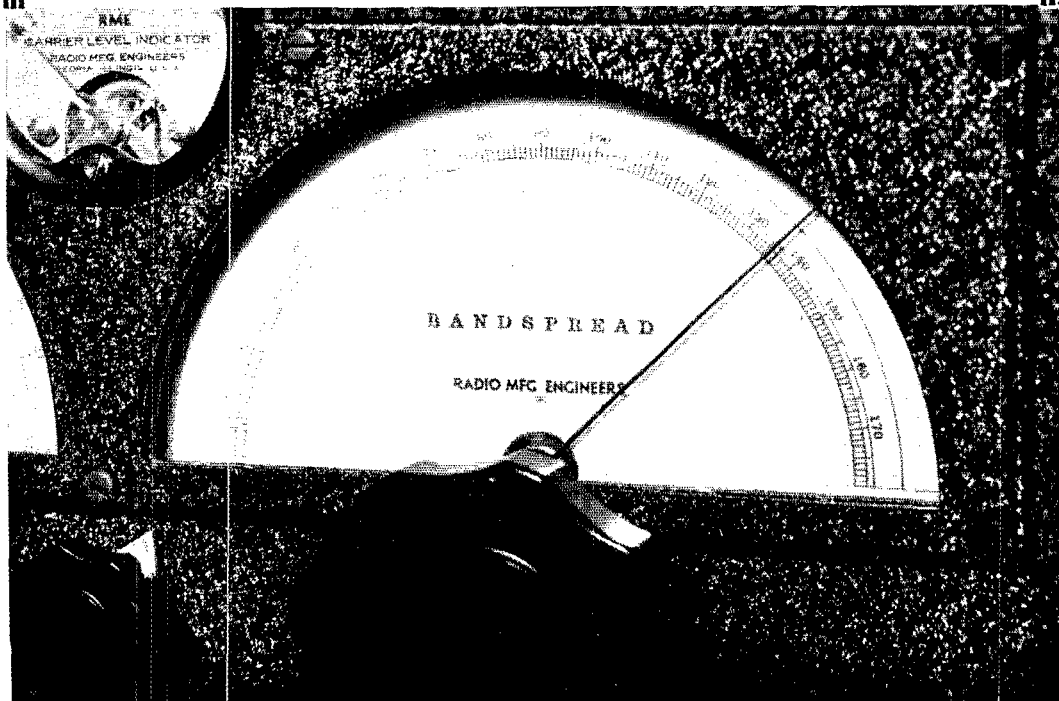

JOHNSON QUALITY ANTENNA ACCESSORIES

Johnson antenna accessories are highly efficient, easier to install, dependable under all weather conditions. And there is a complete line from which to choose—built for engineers, priced for amateur pocketbooks.

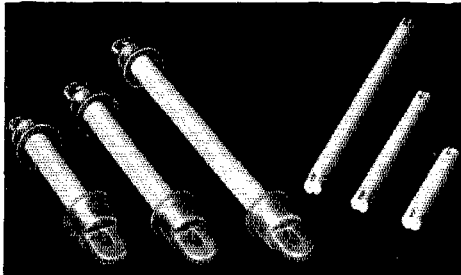

The popular Johnson 1" series antenna insulators (7", 12", and 20" long) are suitable for most amateur transmitting applications. Strong, smoothly glazed, properly designed. For heavy loading, use 1½" Commercial Type individually tested at 1¼ tons.



Three sizes of Feeder Spreaders (2", 4" and 6") and the unique Johnson Transposition Insulator solve your line and feeder insulation problems. For low voltage antenna and guy-wire use, ask for Johnson Airplane "egg" or Cruciform low-capacity insulators.

Don't overlook Johnson Enameled Copperweld Antenna Wire. It is stretch-proof, breakage-proof, corrosion-proof!

Ask your Jobber for free Johnson
Catalog 961-4, or write us now

E·F·JOHNSON·COMPANY 
MANUFACTURERS OF *Radio Transmitting Equipment*
WASECA MINNESOTA U.S.A.
Export Office: 25 Warren St., New York. Cable: "SIMONTRICE"

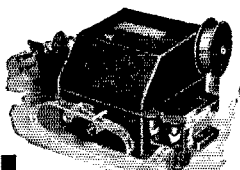

At Last! A Perfected **AUTOMATIC SENDER**

Save your list. Let the Automatic Sender raise your stations for you. Repeats calls or messages indefinitely. Length of messages unlimited. Sends from 2 to 70 words a minute. Motor driven. Entirely automatic. Built-in tape perforator. Absolute uniformity in spacing of characters. Used with buzzer or oscillator, makes excellent code teacher for novice and speed-builder for the advanced amateur. Complete with 4 rolls of tape and full instructions. No extra equipment needed. If your dealer can't supply you, write us.

MONEY-BACK GUARANTEE

Gardiner-Levering Co. Haddon Heights
New Jersey, U. S. A.

only
\$12.50

Postpaid
in U. S. A.

Patent
Pending

Roy S. Quinn, W9DQC, still found plenty of emergency work to do. Aided by ex-W9DDH, he worked in close cooperation with the local Red Cross, handling traffic up and down the river on 3942 kc. with 100-per cent. deliveries.

It was Lyle E. Winn, located at Marion, Ky., W9JEG, whose 160-meter 'phone relayed much of the vital emergency traffic from Paducah and other stricken points. With the aid of W9BOZ a total of 992 messages were handled, Red Cross, police, National Guard and personal. W9JEG was an active element in several 160-meter nets.

Flood waters are like the bacteria they carry—they multiply. The bigger they get, the harder they hit and the longer they stay.

Two weeks after the crest passed in the upper Ohio most business places were cleaned out, power and gas and telephone service were often at least partially restored—normal life was swiftly returning.



W9YJH, 160-METER 'PHONE STATION MANNED BY A CREW OF OPERATORS AT THE HIGHEST POINT IN THE CITY, ONE OF EVANSVILLE'S THREE MAIN RADIO OUTLETS

But on the lower river, in some instances, it will require more nearly two months than two weeks to see the restoration of normalcy. In Paducah, Ky., two weeks after the crest, for instance, it was just beginning to be possible to enter the city from the bridge side without use of a boat. Houses were still wet, undried. Water, power, gas were still days in the offing, telephone service weeks away. . . . Nine-tenths of the city had been flooded.

Many of Paducah's 40,000 inhabitants, it can reasonably be claimed, owe their lives to amateur radio—more specifically to R. O. Moss, W9CHL, who in an initial 120-hour continuous watch without rest was principally instrumental in securing the men and boats who evacuated much of the population after high water had covered the town, a thousand of whom were still trapped in hotels and homes as the crest approached. Working with nine 160-meter amateur stations, the National Guard, Coast Guard, and WPAD (b.c.), W9CHL handled 1552 messages, had a crew of 25 making deliveries by automobile, boat—any way possible. Power failing after 168 hours operation at his home on the Cairo Road, he transferred to the Heath High School for 120 hours more of solo watches. Maintaining the closest cooperation with all local agencies, keeping the 160-meter band humming with traffic to and from Paducah, W9CHL performed one of the

Taylor

HEAVY

CUSTOM
BUILT

DUTY

Tubes

SUPER PERFORMANCE — ECONOMY

"AMATEUR'S POWERHOUSE TUBE"

• T-200 •

**READ THESE
CHARACTERISTICS
— AND COMPARE!**

200 Watts
Plate Dissipation

Fil. Volts.....	10 to 11
Fil. Amps.....	4
Amp. Factor.....	17
Plate to Grid — MMF.....	7

Max. Plate Volts

Unmodulated.....	2500
Modulated.....	2000
Max. Plate M.A.....	350
Max. D. C. Grid M.A.....	80
E G.....	—300

Super Carbon Anode
Size

Length.....	2½ inches
Width.....	1⅞ inches

\$21.50

EASY TO DRIVE

TAYLOR T-200s are ideal for 1 K.W. operation on frequencies ranging from 30 to 1.7 M.C. Good efficiency may be obtained with a kilowatt input at a plate voltage of only 1500. The T-200 type of construction results in as low interelectrode capacities as are consistent with minimum voltage drop across the elements assuring maximum efficiency for a given plate voltage with minimum grid drive requirements. Yet, the interelectrode capacities are low enough for ease of neutralization. 80 watts of driving power under average conditions will furnish ample excitation for 1 K.W. input — plate modulated — any frequency from 30 to 1.7 M.C.

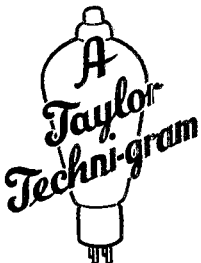

TAYLOR CARBON ANODE TUBES CAN BE RUN AT RED HEAT WITHOUT INJURY TO THE FILAMENT EMISSION

Taylor Tubes are safely rated. At maximum rated inputs the anodes do not show color! All Taylor Tubes are gas-free, and are tested for emission while the plate is white hot. A rough black surface radiates heat four times as fast as a bright metal surface. Hot spots sometimes noticeable in metal anodes are eliminated in carbon anodes which dissipate heat evenly over their entire surface.

TAYLOR TUBES ARE SOLD AND RECOMMENDED BY LEADING RADIO PARTS DISTRIBUTORS

"More Watts Per Dollar"

TAYLOR TUBES, INC., 2341 WABANSIA AVE., CHICAGO, ILLINOIS

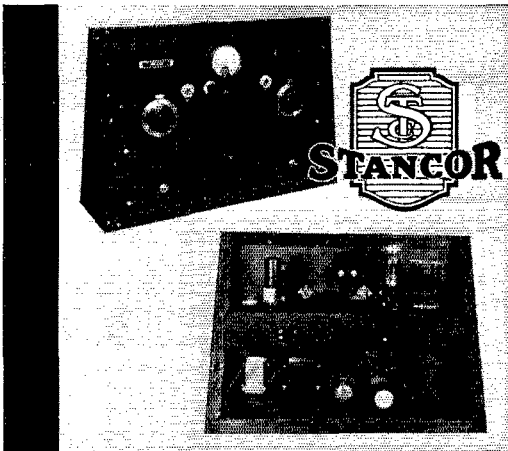

**40 WATTS
OUTPUT FOR
\$40**

A low-cost transmitter that has EVERYTHING! Uses Crystal control . . . 6L6 tube for oscillator . . . Type 10-825 or T-20 amplifier tubes . . . Room for buffer stage or R.F. for phone operation. It's stable . . . efficient . . . compact . . . economical. Build this professional-looking transmitter . . . you'll get perfect performance.

Complete layout template AT-1 with complete operating instructions will be mailed for **25¢**

**STANDARD
TRANSFORMER
CORPORATION**

850 BLACKHAWK ST., CHICAGO

outstanding individual communications jobs of the emergency.

Yet that does not cover all of the debt Paducah owes amateur radio, for there were two amateur stations active in the city.

Some 90 hours after W9CHL's initial QRR transmissions, H. Warren Middleton, W9CXD, a state official, with the aid of John H. Martin, W9NEP, got going on 1900 kc. in the Irvin Cobb Hotel (remember the rotogravure pictures?) at the request of the Red Cross. Working between the Red Cross and WPAD, with the aid of ex-W9APP and Robley Williams, W9CXD operated for 175 hours, handling 560 messages, most of which were then broadcast over WPAD.

At Paducah, as at many points along the river, other services (usually manned by amateur operators!) entered after amateurs had performed the vitally important work of initially restoring broken communications links. On January 28th the TVA steamer *Huvassee* entered the city, with W4CXY operating both under his own call and WWKU. NNP3, a battery-operated portable brought to Paducah by three Marion, Ind., amateurs, made a notable contribution.

Other stations active in Kentucky include: W9CHN* 75, W9CRJ 80, W9EPI (W9PKX, W9OTC, W9NGN)* 75, W9FZL* 75-20, W9KCZ 75, W9SXH* 160, W9SZK 160, W9WNP 80, W9YHK (W9ACD, W9LDL)* 75, and W9YPJ 160.

At Danville, W. C. Alcock, W9CDA, held down the job of N.C.S. of the highly-effective Kentucky net, cooperating with W9EDQ. This 3810 Kentucky net, by the way, deserves some special mention. Springing initially from A.A.R.S. origins, it retained Army efficiency and combined it with amateur informality. To the regular A.R.R.L. Kentucky net members a number of casualties were recruited during the flood emergency, resulting in the following roster of KYN emergency stations: W9AUH, W9AZY, W9BOF, W9BEW (W9CIU), W9CDA/WLHK, W9EDQ/WLHT, W9FQQ, W9FS, W9HAX/WLHD, W9HBQ, W9HXN, W9IFM, W9KOX/WHLU, W9KBR, W9MN/WLHX, W9MWR, W9MYL, W9NAR, W9NEP, W9NKD, W9NWR, W9OMW, W9PXX, W9SDG, W9THS/WLHJ, W9UKD, W9VYY.

Indiana:

On a map the State of Indiana looks like a stubby high-heeled boot with the heel missing. The sole, the last week of January, was mile-wide yellow water outlined by snow-covered bluffs.

Where the heel should have been, at Madison, Ind., the citizens evacuated the mile-and-a-half water front and WPA and C.C.C. workers moved in. During the morning of January 23rd Western Union wires went out and the pre-arranged emergency schedules on 3500 kc. of J. Wright Winn, W9AHA, were put to work. That work continued with 12- to 24-hour daily watches for more than three weeks, with the aid of N.C.R. relief operators W9TYM, W9SUC, and F. F. Smith. In addition to handling much National

OHMITE R. F. CHOKES

Single-layer wound on steelite tubes. Four sizes for use on transmitters in the various amateur bands. Applications fully discussed in FREE descriptive bulletin with diagrams. Write for your copy.

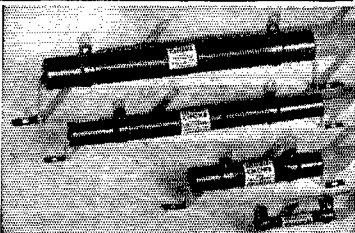

OHMITE MFG. CO. HANDBOOK PAGES 518-519 CATALOG SECTION
Manufacturers of Rheostats, Resistors and Tapwatches
4831 FLOURNOY STREET CHICAGO, ILLINOIS

Reprinted from the **JANUARY 1937**

BOOK REVIEWS

The Radio Amateur's Handbook. Fourteenth (1937) Edition. By the A.R.R.L. Headquarters Staff. 544 pages, 584 illustrations, 74 charts and tables. Published by the A.R.R.L., West Hartford, Conn., U.S.A. Price \$1.00 in U.S.A., \$1.25 elsewhere. Obtainable from R.S.G.B. Sales Dept.

If there is an amateur who has not heard of this Handbook he is probably using a coherer, so it doesn't matter to him; those who possess one or more of the 400,000 copies which have already been issued will want to know in what way the present edition differs from previous ones.

A considerable amount of rewriting has been done, and 200 new illustrations have been included. As would be expected, the new valves necessitate new treatment in the CW and phone designs. Noise silencers are treated more fully and brought up-to-date. Aerials receive more space, especially with regard to directional systems and coupling methods. The most advanced designs in ultra-high frequency equipment are supplied, and this must prove an increasingly attractive section. The charts and tables are even more comprehensive than before, and the seventeen pages of valve data is claimed to be the most complete and detailed tabulation of valve data ever published.

In every way the new Handbook is "bigger and better than ever," and is easily the best value in radio literature that it would be possible to find. The growth and success of the Handbook since its inception has been one of the most marvellous events in the history of amateur radio; not only is it to be found in the shacks of amateurs all over the world, which is natural, but it is used in many schools and technical classes as a text-book, and a first-rate book it is. The writer has found it on an American warship, and the control room of a B.B.C. station, to mention only two.

The amateur who is without a recent copy of this grand book is lacking in something more than money, for its price compared with its value is merely nominal. The A.R.R.L. deserve our heartiest congratulations, but as amateurs we ought to take a pride in the quality of this book, which is so often the ambassador of amateur radio in the courts of the professional. The trouble is that, to read each edition thoroughly as it comes out, one would find little time left for amateur radio.

T. P. A.

\$1 POSTPAID
\$1.25 OUTSIDE
CONTINENTAL
U. S. A.

*Buckram bound — \$2.50
postpaid*

from
AMERICAN RADIO RELAY LEAGUE
West Hartford, Connecticut, U. S. A.

T & R BULLETIN

official organ
of the
RADIO
SOCIETY
of
GREAT
BRITAIN

**Good
Operators
are not
"BORN!"**



**they
are**

**TRAINED
the CANDLER Way**

You can have the same training that made T. R. McElroy, World's Radio Champion. Right now you have the capacity of sending and receiving code as easily as you talk and listen. CANDLER training will develop your *sound consciousness* so that your sending and receiving *sense* will work automatically — without strain or deliberate effort, but with confidence, accuracy and rapidity.

LEARN RIGHT—It's Easy

People who know, agree that CANDLER Training is best. The CANDLER System is taught at Harvard University by Champion McElroy. CANDLER methods are so easy, so interesting, that code skill will just come to you, naturally. You will have more speed after a few days of CANDLER instruction than after months of *undirected* practice. The skilled operators you hear on the air are CANDLER trained. They started by mailing the CANDLER coupon. You have the same opportunity. Mail the coupon today! No obligation.

CANDLER SYSTEM CO.
Dept. Q-4 ASHEVILLE, N. C.

MAIL THIS COUPON TODAY!

■ CANDLER SYSTEM CO. ■
 ■ Dept. Q-4, Asheville, North Carolina ■
 ■ Please send me Free Book of Facts. ■
 ■ Name ■
 ■ Address ■
 ■ City State ■
 ■ Code Speed (if any) WPM ■

Guard, Naval Militia and WPA traffic for local officials, W9AHA also served as an important Evansville-Indianapolis relay point.

At Charlestown the burden of relief communications was borne by Charles M. Jenney, W9KDB, operating portable. In five days continuous one-man watch 603 messages were handled for the Red Cross, State Police and National Guard. North of Charlestown, near Vernon, communications truck WANC from Jamestown, N. Y., was operated by a ten-man American Legion crew including H. H. Willson, W8FYA.

Across from Louisville and just down the river is New Albany, Ind. To this isolated town went Albert E. Fritz, W9USU, after an initial period of emergency operation on 160-meter 'phone at Fort Wayne. At New Albany, with the aid of two relief operators, traffic was handled in the State Police, National Guard, and East Coast Emer-

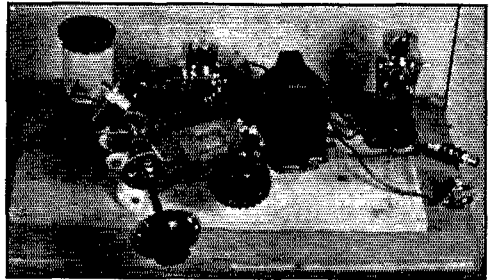

BATTERY-OPERATED RECEIVER ASSEMBLED BY G. W. MOSSBARGER, W9AUH, IN 30 MINUTES AFTER POWER FAILED, BEFORE THE GENERATORS LATER USED ARRIVED FROM CHICAGO

gency nets. The first contact with Jeffersonville, Ind., just up the river from Louisville and also badly hit, was established with W0EG on 7.5 meters. W0EG was one of the General Electric radio sedans, manned by Schenectady amateurs, which had been transferred by the Red Cross from Evansville. Using the call W2ALP/9, one of the trucks scheduled W9KDB at Port Fulton on 160 meters. The other car was operated at New Albany on 30 Mc.

From Evansville to Tell City, entirely isolated, went John McCutchan, W9MOF, as operator of an emergency station rigged by himself and W9GFS, accompanying a National Guard unit. Contact was had with W9GFS as base station; when W9MOF could not receive on the ham frequency broadcast station WGBF provided one side of the circuit.

The city of Evansville is laid out like a crescent, following the rounded outer edge of a hairpin curve in the river with devoted submission. That devotion brought trouble last January, when water backed up through underground water and sewage systems to make the city a muddy lake dotted with three small islands.

But it also brought a distinguished performance by radio amateurs cooperating with a wide variety of official services in a thoroughly successful emergency communications job.

NEW RCA PRODUCTS FOR THE AMATEUR

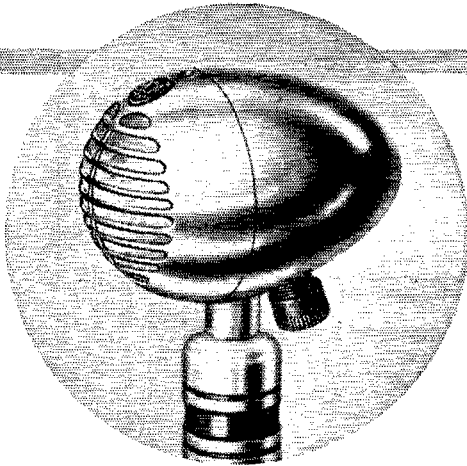

New — Aerodynamic Microphone

This new microphone employs the pressure-operated dynamic principle which gives greater sensitivity, requires no power supply and provides freedom from a-f or r-f field pick-ups. Amateur's net only \$15.90. Attractive stands also available.

Now—RCA V Cut Crystals for 20, 40, 80 and 160 meters at new low prices



RCA V Cut Crystals have won an enviable reputation for reliability, quality, power output and accuracy.

New low prices of \$9.85 (amateur's net) for crystal and ceramic holder for any band mentioned are now in effect. RCA V cuts are ground upon order only. Supplied within 0.1% of frequency specified, calibrated to within 0.005%, and having temperature coefficient of 4 cycles or less per megacycle per degree Centigrade.

ACR-155 Receiver—a better receiver at low cost

The new ACR-155 is winning acclaim for both its striking appearance and brilliant performance. Priced at \$74.50 (amateur's net), it brings within the reach of every amateur the advantages of great sensitivity, good selectivity, and flexibility of operation.

520 to 22,000 kc. frequency range, 9 metal tubes, band change by switch, built-in power supply and speaker, plus the RCA assurance of outstanding performance, are but a few of the many reasons why this is the receiver you should own.

Operating Instructions and Service Notes sent upon receipt of 15 cents in stamps. Descriptive folders free on request.

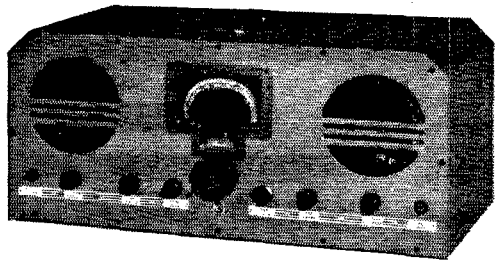

High Quality, Double-Button Carbon Microphone

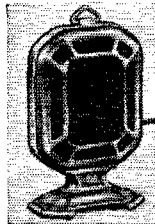

This microphone is outstanding value of its class because of good sensitivity, excellent quality, rugged construction and low-hiss level. Complete with cable and plug for only \$6.90 (amateur's net).

For further information on these and other RCA Products, see your distributor or write to



for Amateur Radio

RCA MANUFACTURING COMPANY, INC. • CAMDEN, N. J.

Say You Saw It in QST — It Identifies You and Helps QST

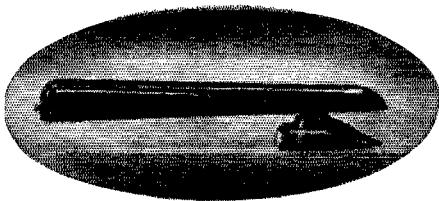

AN ENTIRELY NEW
CRYSTAL RECORD REPRODUCER
SHURE ZEPHYR

A completely new crystal pickup that marks another milestone in pickup progress! Exclusive "needle-tilt" Balanced-Tracking increases record life. Improved wide-range frequency response gives higher fidelity . . . more accurate life-like reproduction. New beautiful streamline design. Plays 10 and 12 inch records. **List Price . . . \$12**

Don't fail to try the ZEPHYR. Let its superior performance prove how much better the ZEPHYR really is!

See your Jobber or write for Bulletin 143Q.

Licensed under patents of the Brush Development Company.
Shure patents pending

SHURE MICROPHONES
SHURE BROTHERS • MICROPHONE HEADQUARTERS
225 WEST HURON STREET • CHICAGO, U. S. A.

THE SUPER SKY RIDER

THE SKY CHALLENGER

THE HIT OF THE YEAR! . . .
The SKY CHALLENGER

We are delighted to recommend this outstanding new receiver to every amateur radio operator. Here's a highly efficient communications receiver, quality-engineered and precision-built, that has the features you need for short wave reception at an amazingly low price. Covers all the active radio bands including the 10 meter band (38 mc. to 535 kc. without gaps). Nine tubes — 5 Band 338° Dial — Iron Core I. F. Transformers — Electrical Band Spread — Continuously Variable Tone Control. — Write today for complete details.

\$69.50

THE ARNOLD CO.
Wholesale Distributors
Amateur and Commercial Radio Supplies
527 WEST BROAD STREET
RICHMOND, VIRGINIA
"THE VIRGINIA HAM HEADQUARTERS"
W3FBFL W3EJHL

the hallicrafters inc.

THE SKY BUDDY THE SKY CHALLENGER THE SKY RIDER COMMERCIAL THE SKY CHALLENGER

Coordination tells the story of the Evansville flood work. With Lieut. Ben J. Biederwolf, N9VAI, organizing the general amateur activity concurrently with watches at his own N.C.R. station and Roy McConnell, W9HBS, in charge of Evansville's police radio, managing local communications generally by authority of the National Guard, each amateur was given a specific sphere of activity in which to perform.

At W9VAI, with five Coast Guard and four N.C.R. operators, approximately 6000 messages were handled in 23 days' continuous operation, mainly for the Red Cross and Coast Guard. This station, a member of the Indiana Naval Militia, was taken over by the Coast Guard, controlling the large mobilization of boats throughout the entire region.

W9HBS, operated on 75-meter 'phone with the aid of W9HFR and W9KVE, was the principal communications center for the National Guard. Considerable traffic was cleared, and direct telephonic communication between Evansville and Indianapolis provided. Later, W9HBS was made LC9E and transferred its activities to 3550 kc., 'phone. The station also tied in with the State Police net. In 408 hours of operation 554 messages were handled.

W9YJH, operated by J. Max Pemberton, W9KVE, W9GZB, W9UMS and W9OMS, being flooded out of its home QRA, was re-located in Reitz High School, a hill-top location, highest in Evansville. Working on 160 in the Northwest net and practically every other, with a b.c.-amateur hookup for the Red Cross, the station handled 417 messages in 17 days, 40% being Red Cross, 40% National Guard and other official, and the rest personal. Franklin Cox, W9RZM acted as alternate to W9YJH, stepping in when the station went off the air briefly and standing by at other times; W9OMS also operated W9RZM and aided at W9GFS.

Philip Hatfield, W9GFS-W9JXB, after aiding the N.C.R. in preliminary hook-ups, served primarily as base station for W9MOK, who accompanied a jointly-created station to Tell City. He handled a quantity of personal traffic in addition.

Although occupied primarily at WGBF-WEOA, of which he is chief engineer, Fay A. Gehres, W9AIN, was on during free moments. The same was true of John Caraway, W9BZF, Richard Seitz, W9VFE, Erwin Schoeny, W9IGT, Hoyt Garner, W9TAJ, who did double duty on their b.c. jobs. Jake H. Heugel, Jr., W9MRR, set up in the Evansville Press Office and tied in with the Red Cross.

Other radio facilities in the Evansville region based on amateur operators included CX9G, operated for the Indianapolis State Militia with S.C.M. Arthur L. Braun, N9TE, in charge, and W9FKI, W9SPB, W9IBA and W9GZE as operators. The General Electric radio sedans, W2XJH-WOEG, and W2XAS-W2XAT, which operated in Evansville until Feb. 1st, were manned by Schenectady amateurs. They provided local mobile service for the National Guard.

As in the other states, throughout Indiana other amateurs, although not actually in the

Precision Instruments for Electronic Testing

— from the complete C-B Line you will be certain to find an instrument to meet nearly every modern testing problem. For a complete description, secure the new catalog.

MODEL 105—1" Oscilloscope

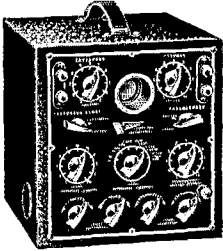

Compact in size, low in cost — yet complete in every way. Has wide range linear sweep, dual high gain amplifiers, and self synchronizing circuit. A necessity for efficient operation of the modern phone station. Net cash \$48.90. Only \$5.50 down.

MODEL 79-B Audio Oscillator

Range 20 to 15,000 cycles with less than 2 db. variation in output voltage and not over 5% distortion content. Highest output, 27 volts or 150 milliwatts. Has 6E5 zero beat indicator and vernier selector dial. Operates from self-contained power supply. Net \$56.50. Only \$6.50 down.

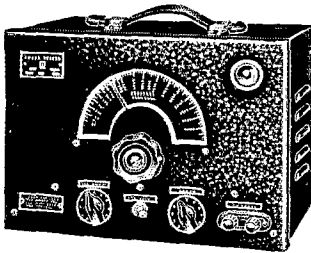

AC-DC Volt-ohmmeter

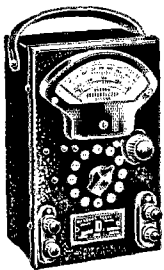

The MODEL 85 Unimeter meets every need for measuring AC voltage, DC voltage and current, ohms, etc. Has a 5-inch fan type meter with large easy-to-read scale. Blocking condenser removes DC potential when measuring receiver output. Furnished complete with battery and test leads. Net \$28.90. Only \$4.00 down.

Write for the complete C-B catalog or advise our application engineering staff of your measuring problem. They will gladly cooperate in determining the best methods and equipment.

The CLOUGH-BREngle CO.

2813-C W. 19th St.

Chicago, U. S. A.

Cable address — CEBECCO, Chicago

emergency zone, operated on about the same basis of long hours of concentrated activity. The following were particularly helpful: W9AAI* 75, W9AB 80, W9ABB/WLHM 80, W9ADX 160, W9ALQ 80, W9AKI/BU4 (W9SDQ, W9LXQ, W9NCI, W9JRK)* 160, W9CFJ 75, W9LTT 75, W9CVN 80, W9DLI 80, W9EGV 80, W9EPT 80, W9FKE* 75, W9FQ 80, W9HLO 80, W9HSF 80, W9HZH 80, W9IU 80, W9JHQ 80, W9JRK/WLHV 80, W9KOB 75, W9LWE 80, W9MFM 160, W9MM 75, W9MTZ 5, W9ODH 80, W9QG/WLHL 80, W9RE/LC9K*, W9SDP 80, W9SGF 75, W9SKE 75, W9SYJ/LC9X* 75, W9TBM 80, W9TGC 80, W9TYF 7, and W9YRR 160.

The following Fort Wayne amateurs operated at various points in the flooded area aiding the State Police: G. H. Graue, W9BKJ; Robert W. Sanders, W9LKI; Gene C. Finn, W9PSY; Paul E. Miller, W9REW; Fred P. Reynolds, W9SKE; and, previously mentioned, W9USU.

Special mention should be made of the Indiana Naval Militia, composed of the state's N.C.R. members. These amateurs went into such towns as West Baden, Bloomington, Evansville, East Enterprise, and New Albany and manned portable or permanent stations 24 hours a day under Naval calls. The participating amateurs: W9AGZ, W9AIY, W9CB, W9CLE, W9DUO, W9DVO, W9EZR, W9FHZ, W9GOS, W9HPQ, W9MU, W9MVS, W9NQD, N9NXN, N9STQ, W9TBS, W9TDX, W9TMF, W9VAI, and W9YZQ.

Illinois:

At many points the flood emergency communications work was compared with that in time of war. In the southern Illinois territory this comparison was surprisingly apt.

For here was no single stricken city, no solitary isolated community along a river front. Here the flood achieved a character not approached at any other point—here, in southeastern Illinois, edge of the region beginning at the junction of the Wabash and the Ohio colloquially termed "Little Egypt," there was no river, but a vast inland sea at maximum fifty miles in width; studded, it is true, with islands as high spots occurred, but shoreless farther by far than eye could see. Here many communities were surrounded with water, isolated, cut off by road and by wire, accessible only by boat—and by radio.

In this territory—not widely publicized in the newspapers, for it happened that mostly small communities and rural districts were affected—operated a most unique and effective amateur communications system, comprised basically of 160-meter 'phone stations located at strategic points throughout the region. These stations, some of them at their permanent locations, others brought in from as far away as Chicago provided a complete and indispensable inter-communicating telephone system for the National Guard and other official agencies which covered every city and village in the area.

At Rosiclare, half-way between Paducah and the Wabash-Ohio junction, Orville Troutman, W9IBS, relieved by W9NBS, handled a thousand messages in 23 days, among other things aiding in

VACUUM **EIMAC** TUBES

*... "When they asked me how I
did it,*

*I gave them the Scripture text:
'You keep your light so shining,
A little in front of the next.' "*

*... "They copied all they could
follow,*

*But they couldn't copy my
mind.*

*So I left them sweating and
stealing*

A year and a half behind."

—KIPLING

EITEL-McCULLOUGH, INC.

San Bruno, California, U. S. A.



IN WORLD-WIDE USE
C-D
DYKANOL
TRANSMITTING
CONDENSERS

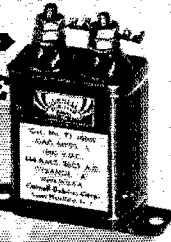

are now in use in more than 50 countries throughout the world. Under every conceivable condition of temperature and climate, these fine capacitors deliver the unflinching, dependable service so vital to commercial and amateur broadcasting. Thousands of letters in our files from hams the world over prove that C-D Dykanols render complete satisfaction. For your condenser requirements . . . standardize on **CORNELL-DUBILIER!**

For complete listing send for FREE catalog No. 133A

MICA • DYKANOL • PAPER-WET & DRY ELECTROLYTIC

CORNELL-DUBILIER
CORNELL-DUBILIER CORP.
 1013 HAMILTON BOULEVARD • SO. PLAINFIELD, NEW JERSEY

SENDING and RECEIVING with the same Antenna

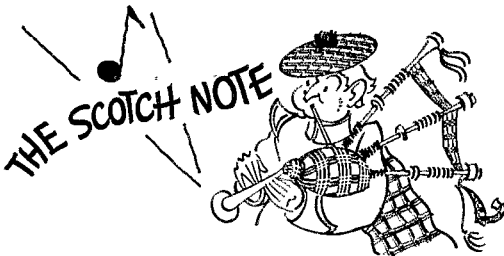

Amateur demand for a *Low Priced* Midget Radio Frequency Relay for low powered transmitters has forced us to bring out a brand new instrument. It is described on the new page 6 of Bulletin 507B. Send for it.

|| WARD LEONARD || RADIO SPECIALTIES ||

WARD LEONARD ELECTRIC COMPANY

41 South Street, Mount Vernon, N. Y.

Please send me page 6 of Bulletin 507B.

Name

Street

City and State

Call Signal

the evacuation of Ullin; a gasoline generator provided emergency power.

Willie L. Watson, W9UWS, at Galatia, handled 650 messages with the aid of a State Police operator from Springfield. In addition to the official traffic, the station effectuated a direct rescue of a family of five, including three children. Operating portable at Vienna with 25 watts input, Glen L. Key, W9BEG, handled 300 messages; together with W9AQY, this station dispatched boats to Ullin, evacuating 300 refugees.

At DuQuoin Albert Eugene Schumaker, W9SLW, relieved by W9RWL, W9WED and W9YHV, handled traffic and worked in close cooperation with WQPD, the State Police station at DuQuoin, as did practically all of the amateurs in the net. W9MOD, Anna, operated by the Rev. Delbert S. Lacquement, assisted by W9GRG and W9CSN, served as key station with two portables which were sent to isolated places without other means of contact. T. B. Thompson and XYL, W9VRC, at Dangola, cooperated with the N.C.R. net, and was instrumental in rescuing marooned people and delivery of chlorine and hospital supplies to Metropolis.

The amateur stations imported by the National Guard for work in the smaller communities in the large flooded region did particularly effective work. These included H. H. Grigsby, W9FEU, and Wm. L. Birren, W9BFD, of Peoria, who set up NDSF (1760-kc. 'phone and 2670 kc. c.w.) at Shawneetown High School, refugee center a mile and a half from the city; J. W. Stanton, W9PSP, of Chicago, who operated 3900-kc. 'phone at Equality; and DG9C/NDS2, 3675 kc. c.w., set up by Elmer Todd, W9PCI, of Centralia, W9NMZ and W9SLU relieving. These stations worked among themselves, with other networks, and with such other stations as Q8K (Coast Guard station at Cairo), NMG (Mobile, Ala.) and NNP (Evansville), broadcasters, etc. They were all on active duty until middle February. When to all the rest of the world the flood had ended, they still sat at their receivers, surrounded by miles-wide stretches of water.

W9UIH, the station of Dr. Otis B. Young of the Southern Ill. State Normal University, Carbondale, operated by Dr. Young, W9UZC, W9VBT, W9THT, W9WSU, W9YIU and W9SNS, handled 283 messages in ten days' continuous operation. Warner Anderson, W9UZL, who also operated at W9UIH, took a 20-watt portable first to Villa Ridge and then to U. S. Dam 53 and, aided by W9NET and Ralph McClusky, handled 200 messages; with but 5 watts available at one stage and serum badly needed, W9RRX was raised, airplane delivery secured, and a dangerous situation saved.

A veritable odyssey was the experience of Martin P. Schroedel, W9RUY, who with Harley Hammack set out from Pinckneyville with a prized 10 watt portable to find some emergency work. Arriving at Harrisburg, National Guard headquarters, Col. Davis (commanding) ordered them at first to Norris City, then New Haven. At that place, completely flooded, they provided all emergency communications for a period of

What's behind the name on **BURGESS BATTERIES?**

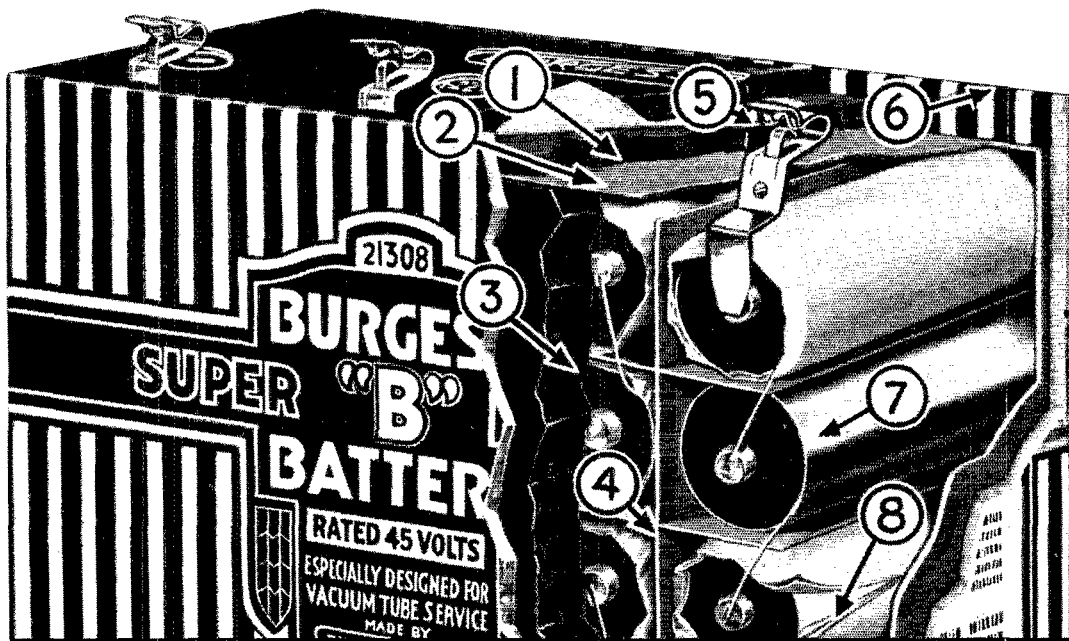

—and what that means to you

- 1—Double strength top seal.
- 2—Moisture-proof inner container.
- 3—Inner seal cementing cells into a solid block.
- 4—Moisture-proof insulating cell partitions.
- 5—Reinforcing strip in top seal.
- 6—Black and white striped water-proof container.
- 7—One-piece, drawn, seamless zinc can.
- 8—Moisture-proof cell wrapper.

There's a reason for every one of these features of Burgess Radio Batteries. Individual cells have moisture-proof coverings. They are rigidly connected together and sealed to insure permanent protection against moisture and other deteriorating agents. Seamless zinc cans are used in all Burgess Cells. Uniform in thickness they greatly increase active cell life.

The plus ingredient — **CHROME**

All Burgess Batteries contain "Chrome," the exclusive Burgess preservative which greatly increases battery life, especially during periods of idleness. Enjoy battery economy and dependability — use Burgess Batteries.

BURGESS BATTERY COMPANY, Freeport, Illinois

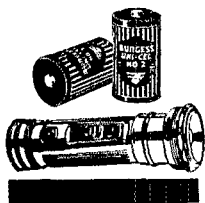

BURGESS



Say You Saw It in *QST* — It Identifies You and Helps *QST*

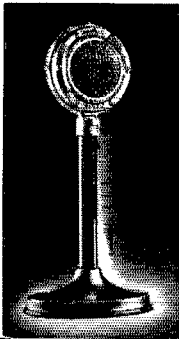

SIMPLICITY EFFICIENCY DEPENDABILITY

You don't need transformers, exciting current batteries or polarizing voltage when you use a Shure 70S "Communications-Type" microphone — simply connect direct to grid of amplifier. No troublesome AC hum — no carbon hiss — no circuit complications.

The carefully engineered special rising response of the 70S *doubles power* on important intelligibility speech frequencies — gives phone signals a real "punch" that cuts right thru QRM and QRN.

For most effective 'phone work, use the microphone that many Police, Radio, Airways, Commercial and advanced Amateur stations depend on — the Shure 70S.

List Price, complete with integral desk mount and cable..... **\$25**

See your Jobber or write for Bulletin 137Q

Licensed under patents of the Brush Development Company. Shure patents pending.

SHURE MICROPHONES
SHURE BROTHERS • MICROPHONE HEADQUARTERS
225 WEST HURON STREET • CHICAGO, U. S. A.

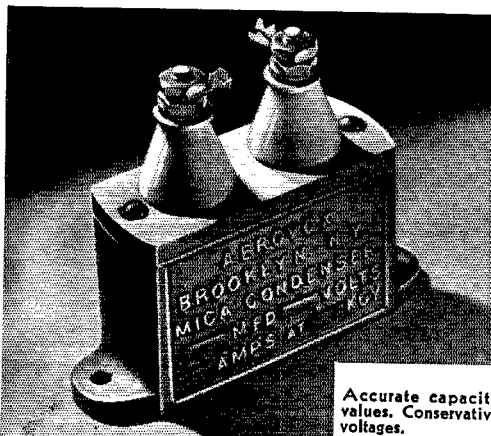

Accurate capacity values. Conservative voltages.

Molded bakelite and metal-case types.

1000 to 7000 v. ratings. .0005 to .1 mfd.

Each unit plainly stamped with values.

Fully impregnated against moisture penetration.



LASTING!

Whether tiny "postage-stamp" molded bakelite unit or the aluminum-case unit here shown, AEROVOX mica capacitors are built to stand the gaff. • Thirteen types to choose from. • Send for latest catalog.



days, then returned to find their home city a refugee center and another job of operating on behalf of Red Cross headquarters awaiting them.

Roy Raybourn, W9JUP, at Marion, found most of his work in establishing contacts on behalf of the U. S. Army station, PB4, located at the Army flood relief base at that point. W9NCK, W9WQZ, W9WPP and W9WPO were also on in Marion.

At Cairo, scene of the dramatic struggle between man and the river, no amateur radio station now exists. To the tense scene, as the citizenry waited with taut, fearful anxiety behind their levees while the mighty "aquatic pincers" tightened their relentless grip, went R. C. Riseling, W9BJE, and M. F. Sawyer, W9UWL. Setting up their stations, they performed until Coast Guard, broadcast pick-up and other official stations had arrived in sufficient numbers (after eleven days) to make their presence no longer essential. During the intervening period, W9BJE, aided by W9CED, W9WSU, Jimmy Sims of WEW and M. McCloughry, handled a total of 350 messages, nearly all official. W9UWL achieved such a reputation during this operation that while going back home he sold his transmitter en route, on the basis of its flood performance! W8KIR, with portable-mobile WGBE operated in the vicinity of Cairo maintaining schedules with army and amateur stations.

The foregoing work, except where otherwise stated, was all on 160 meters, with the exception of one or two stations which handled an occasional message on lower-frequency bands. There was, however, plenty of 3.5-4 Mc. work in the region, as well.

W9HQD, K. E. Schonert, of Harrisburg, was active continuously for two weeks on 3920 kc. Operated by Schonert, W9AZU, W9MWC and Sparkie Mathews of WQPS, the station handled 1800 messages, enabled Governor Horner to talk personally with National Guard officials through the area, broadcast flood warnings (they had a larger audience than the local b.c. station, also operated by W9HQD!), maintained contact with National Guard observation planes (which used 75 meters while surveying the river seeking marooned refugees and dropping supplies), relayed to boats, and provided a variety of other valuable services.

Directly east of Harrisburg, on the river, lies the village of Shawneetown, population about 1400. Recognizing that its people, feeling safe behind a 60-ft. levee, might not realize that backed-up flood waters were cutting them off, Robert T. Anderson, W9MWC, took his exciter unit, an all-wave battery receiver, and, with some batteries, set out for Shawneetown. After a harrowing series of adventures in sleeting 12° weather, including near-capsized boats, and a mile of rowing with one oar, he finally landed on a railroad crossing with a dozen other shivering refugees, six miles from Shawneetown. It was impossible to go further. Setting up in the dark and bitter cold, he tried to work W9HQD, who was constantly listening, but was blotted out by interference. W9ELL and later W8CXR were able to

Multi Match

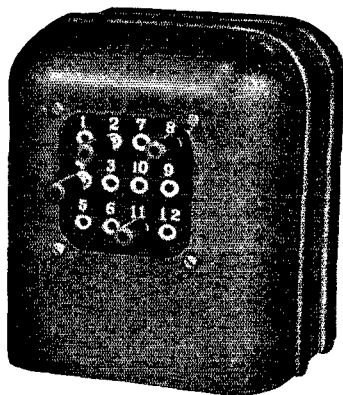

MODULATION

TRANSFORMERS



BY

THORDARSON

WITH THE NEW FEATURE "PLUG-IN-TERMINAL BOARD"

The only Modulation Transformer built with "Plug-in-Jack Terminal Board." Match any tube to any load instantly with simple plug and jack connection. A sensational departure from soldered terminals and connecting posts. New graceful space saving streamline case design. Absolute moisture and humidity proof construction throughout. Will safely withstand tropical climates.

COMPARE THESE FEATURES

1. "Plug in Jack Terminals" for input and output.
2. Complete variable matching.
3. New modernistic case design.
4. Minimum space factor on chassis.
5. Completely compound filled.
6. Double varnished and baked.
7. Moisture proof.
8. Moderate price.

FURNISHED IN FOUR SIZES AS FOLLOWS

	Connected	
	Series	Parallel
T-11M75 For up to 50 watts		
Max. Pri. M.A.D.C.....	100	200
Max. Sec. M.A.D.C.....	80	160
T-11M76 For up to 125 watts		
Max. Pri. M.A.D.C.....	210	420
Max. Sec. M.A.D.C.....	160	320
T-11M77 For up to 250 watts		
Max. Pri. M.A.D.C.....	250	500
Max. Sec. M.A.D.C.....	250	500
T-11M78 For up to 500 watts		
Max. Pri. M.A.D.C.....	320	640
Max. Sec. M.A.D.C.....	320	640

FREE

Send today for Bulletin SD-275 or see your parts distributor.

FREE

THORDARSON ELECTRIC MFG. CO.

500 W. HURON ST., CHICAGO, ILL.

Demand "Power by Thordarson"

"STREAM-LINE" POWER HOUSE

(Patent Applied for)

"A Lap Ahead
o' the Field"



Plate Transformers
Swinging (1st Position)
and Filter (2nd Position)

Chokes and Modulation
Transformers

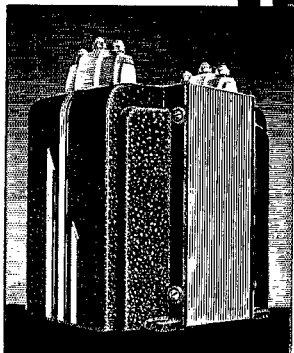

RADICALLY new design gives cool-running efficiency — saves up to 25% in bulk and weight. All-over housing clamps core all-around, preventing lamination hum, shields, protects coils, keeps moisture out. Coils moisture-proofed by GTC "Pull-Push" Process. Ask your jobber or write for Bulletins 35 and 42 with diagrams — **FREE!**

GENERAL TRANSFORMER CORP.
518 Throop St. Chicago, Ill.

LOOK FOR THE NAME BIRNBACH ON INSULATORS THEN YOU ARE SURE YOU HAVE THE BEST!

... and that's because Birnbach are pioneers, creators and manufacturers of the largest and most complete line of reasonably priced insulators in the industry. Notable among Birnbach "firsts" are Feed Thru Insulators with Insulating Bushings, in use throughout the world. Ask for them by name!

Feed Thru Standoff Insulators



An original Birnbach development. Two pieces. Designed and proportioned for maximum strength. Brass nickel plated hardware supplied.

Cat. No.	Height	List Price
No. 453	1/8"	\$0.12
No. 478	1"	.20
No. 478J	1"	.25
No. 4125	1 1/4"	.25
No. 4125J	1 1/4"	.30
No. 4234	2 1/4"	.55
No. 4234J	2 1/4"	.80

Stretchless Copperweld Enamel Antenna Wire

Steel case, copper covered, heavily enameled, low R.F. resistance. Fine for x'mitting doublet and directional antennae.
No. 12 Gauge — 100 ft. List price... \$1.58
No. 14 Gauge — 100 ft. List price... \$1.10
Special lengths to order

EO1 Transmission Cable



No. 956 — 100-ft. spool. List price... \$10.00

BIRNBACH RADIO CO.
145 HUDSON ST. BIRCO NEW YORK, N. Y.

relay, however, and eventually relief arrived at Shawneetown, and the thirteen frozen but jubilant refugees were removed. Anderson went on to Shawneetown, installed his equipment aboard a boat, worked there for several days until the terrific mental and physical strain took its toll. Hospitalized for a brief period, he resumed his trick at W9HQD before the emergency ended—one of the outstanding heroes of the flood emergency.

Norman Ward, W9EWU, assisted by W9KYH and W2GOW, operating in the City Hall at Benton, handled large quantities of traffic on 75-meter 'phone in the N.C.R., A.A.R.S. and A.R.R.L. nets, on behalf of the Benton flood relief committee. Illinois' Lieutenant-Governor and the Speaker of the House of Representatives visited the station and used it for their traffic.

The southern Illinois emergency work was performed by a series of interrelated, loosely-organized networks made up of groups of stations which regularly scheduled each other. Most of these stations operated under the aegis of the Egyptian Amateur Radio Society. One such network was organized by "Radio Ralph" Gasparotti, W9WDZ, of Collinsville, Ill., who, with his XYL, handled 2200 messages on 160-meter 'phone. The net extended to Paducah and Tennessee, and included W9GSS, W9UAK, W9VLS and W9UWL.

The following additional Illinois stations, not located in the emergency zone, were engaged in flood activity: W9AND* 40-75-80-160, W9ANR/WLT (W9KUD, W8PMN/9)* 80, W9BEN 80, W9BPY 80, N9CA 80, W9CJH* 75, W9CZL, W9DLD 75-80, W9EBX 80, W9EQX 80, W9ETI 75-160, W9HPG 80, W9HQH 80, W9ILH* 80, W9JLK 80, W9KJY 80, W9KML, W9LBR 160, W9LIG 160, W9LLX 90, W9LW 80, W9MDO 40-10, W9MWU* 160, W9MZT 160, W9NLP* 75, W9NXE 80, W9NXA, W9PLL 80, W9PNY 80, W9PZ 75, W9RRX, W9RSC* 75, W9RXA 160, W9SII 80, W9SKF, W9SKI, W9SUQ 160, W9TAK, W9TFH, W9TSN, W9UMS 160, N9UZ* 80-40, W9VLS 160, W9VZV 160, W9WC* 75, W9WWI/LC9I* 75, and W9YIH 80-160.

Mississippi Valley:

Most of the people in the Mississippi River Valley had a hard time getting excited about the January flood. In fact, they don't usually get excited about floods at all. They take things as they come, quite matter-of-factly. When the water gets too high for comfort they simply move somewhere else until it goes down; that's all there is to it.

And, of course, the January flood along the Mississippi never did approach the historic records of the past. It looked rather bad between Cairo and Memphis for a time, and the eastern newspapers were filled with gigantic headlines about how the Army was going to evacuate another million people. But the old river folk just looked down their noses in derision. All this flood hysteria was amusing to them—nothing more.

Something of this same realistic attitude prevailed among the radio amateurs of the valley.

Two Champions

Each a Leader in Its Class

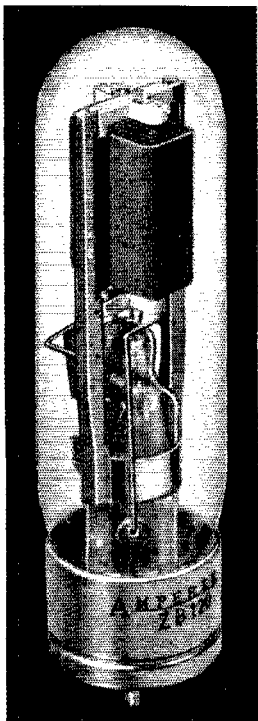

AMPEREX ZB 120

The new amateur CLASS "B" TUBE that is winning instant acceptance from amateurs. It is a practically distortionless Zero Bias Amplifier, a high current low voltage tube that also lends itself readily to all experimental operations. (The Amplification Constant of 90 is sufficiently high to allow practical zero bias operation.) Ideal for use in a Class B Modulator stage, Class B Linear stage, Frequency Multiplier or as a Grid Modulated Power Amplifier.

Amplification Factor.....	90	\$10.00
Grid to Plate Transconductance at 100 ma.....	5,000	
Filament Voltage.....	10 volts	
Filament Current.....	2 amps.	
Maximum Allowable Plate Dissipation.....	75 watts	

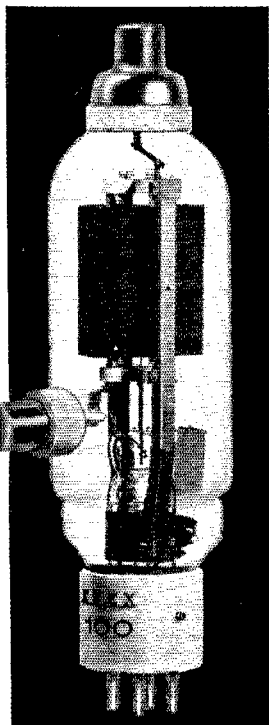

AMPEREX HF 100

Thank you, amateurs . . . for your many letters of praise. In designing this HF 100, we presented you with a tube that we realized would be "Tops." For, even though it has produced amazing results in the ultra high frequency field, its range of operation extends into various stages of R.F. and audio, delivering power outputs usually obtained from tubes selling for almost twice its price.

Filament . . . Voltage 10 volts, Current 2 amps.	\$12.50
Amplification Factor.....	
Grid to Plate Transconductance @ 100 ma.....	4200
Direct Interelectrode Capacitance:	
Grid to Plate.....	4.5 uuf
Grid to Filament.....	3.5 uuf
Plate to Filament.....	1.4 uuf

AMPEREX ELECTRONIC PRODUCTS, Inc.

79 WASHINGTON STREET

BROOKLYN, NEW YORK

NEW FEATURES

OF MODEL D-104

ASTATIC CRYSTAL MICROPHONE



The time-proven D-104 is NOW available in a new, beautifully finished bright chromium case — with a thickness of 13/16" instead of 1" as formerly. It is NOW also equipped with high grade plug and socket, including the Astatic special spring cable protector, which insures freedom from cable breakage at the mounting. At no increase in its famous low price, built rugged for long service, giving quality "speech range" performance under all conditions, the D-104 is more than ever the favorite of amateurs the world over. List Price \$22.50.

LICENSED UNDER BRUSH DEVELOPMENT
CO. PATENTS — ASTATIC PENDING

ASTATIC MICROPHONE LABORATORY, INC.
DEPT. Q — YOUNGSTOWN, OHIO, U. S. A.

WE OFFER —

Specialized personal service of genuine value that is not available from other jobbers.

Time sales of all receivers and transmitters with terms arranged to suit you and 6% finance charge. We finance our own paper. Trade in your equipment for the down payment.

Complete stock of all amateur apparatus at net prices.

TRADE IN YOUR RECEIVER

All receivers shipped on ten day trial. You need send but \$5.00 with order, balance C.O.D. These receivers in stock:

RME-69s Complete	\$151.20
The new 1937 Breting 14s	99.00
The new RCA ACR-155	74.50
RCA ACR-175s	119.50
The new 1937 Super Pro	238.14
The new Hallicrafters Sky Challenger S-15	69.50
Hallicrafters Sky Buddys	29.50
Hallicrafters Sky Chiefs	44.50
Hallicrafters 1937 Super Skyriders S-11	89.50
Hallicrafters Ultra Skyriders S-10	99.50
The new Patterson PR-15 (now ready)	109.50

TRADE IN YOUR TRANSMITTER

All Collins, Harvey, RCA, RME, Temco, Ottawa, All Star transmitters at net prices. Sold on terms to suit you with two years to pay and 6% interest charges.

HENRY RADIO SHOP

211 North Main Street

BUTLER, MISSOURI

To it, however, was added the understanding lent by experience of the horrors of the Ohio Valley disaster. The emergency communications work performed by these amateurs, both in their own behalf and to aid the work on the other river, was tinged with just that mixture of realism and understanding.

Francis Holland, W9OUO/WUCE/WUFJ, was located at the crux of the entire situation—C.C.C. Camp No. 3729, New Madrid, Mo.—where he operated in the A.A.R.S. and C.C.C. networks. Subsequently this station was moved to the eerie parlor of a funeral home in Sikeston, Mo.; in the same city George P. Plattenburg, W9VID, was active on 160-meter 'phone.

Down the river, at Caruthersville, which, although the water was the highest in history and all wires were out, was secure behind its levee, J. J. Gallian, W9JNG, performed a consistent communications job for a variety of agencies on 160- and 75-meter 'phone. A total of 640 messages were handled, many of them of vital importance in providing workers and supplies for the emergency levee construction and repairs.

Up the river at Cape Girardeau, Mo., Glen Keller, W9CZI and XYL, assisted by W9KAL, and Fred Whitson, W9GEF, provided the only communications available to the State Highway Patrol Office at Jefferson City with Sikeston, Mo. From this point F. L. Schneider, W9ECE/9 went to Charleston with a 10-watt 3842 kc. portable which he operated in an automobile in the courthouse yard, working W9PXX at the key of W9ECE's home station, until commercial equipment could be brought down from St. Louis.

Elsewhere in Missouri the following stations participated: W9AIJ 80, W9BGE 75, W9CHE 75, W9CIQ* 80, W9CJR* 80, W9EFC 80, W9FJV 80, W9GCH (W9HVT) 80-40-160, W9KEF* 75, W9OQI 80, W9OUD 80, W9PZV 80, W9RDH 80, W9SGP/WLUK 80, W9YHS 160, W9YMA (W9TA, W9NFA, W9KFL, W9FQY, W9COH, W9HWD, W9CQB, W9GDY, W9NTH, W9BSH, W9GVE, W9CCZ, W9COT, W9NEV, W9FPA, W9NBE, W9BQI)* 80, and W9ZK 75.

On Sunday, the 24th, it was reported that Tiptonville, Tenn., was in a dangerous situation because of the rising waters. D. G. Stewart, N4AFI, loaded his station onto a truck and succeeded in reaching the city despite water over the roads. Working into the Tennessee net, with battery power, communications were provided for the Red Cross, Army Engineers and National Guard. On Friday, the 30th, Stewart was relieved by W4AQV and W. A. McGehee, who operated N4AFI on 3520-kc. 'phone with W4FK, W4AEE and W4ASC, until February 10th.

The Tennessee net, which handled initial emergency communications for the state, consisted of W4DEP, W4LC, W4LQ, W4DDF, W4ALO, W4JU, W4AJJ, W4AYE, W4BM (W4DWS), N4AFI, W4PL, W4CXY, W4RO, W4BQK, W4BOZ, W4LBA, and W4FX.

W4FK was the key station in an important network which included the river boats of the U. S. Engineers and points in the Arkansas and Ten-

KEEP YOUR SCHEDULES

Consistently!

WITH

Utah

**ADD-A-UNIT
AMATEUR
TRANSMITTER
KIT**

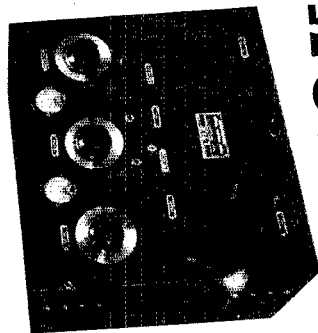
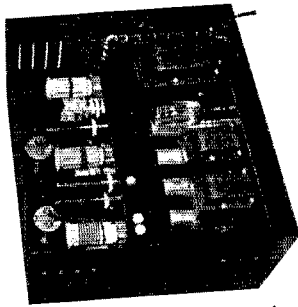

Only

\$49.75

This powerful CW Transmitter can be yours at this amazingly low price. Every part you need — except tubes, meters and crystal, to have a completely self-contained amateur transmitter, is in this one kit. You benefit from UTAH'S 15 years' experience in the design and manufacture of outstanding radio parts.

We show you how to build this transmitter yourself — at a fraction of the cost of a factory assembled job. Later on you can plug in additional units, built from UTAH kits, and have a complete professional style 400 Watt Phone Transmitter.

Start now and start RIGHT, with this UTAH kit. See your UTAH jobber. If he is not listed, write direct to us — TODAY! Address dept. Q-4

THESE UTAH JOBBERS HAVE BEEN SELECTED

because they are capable and willing to serve amateurs with fairness and understanding. See your nearest UTAH jobber. Akron: Brighton Radio Parts Co. Baltimore: D'Ella Electric Co. Bridgeport: Dea Radio Co. Buffalo: Montgomery Ward & Co. Chicago: Allied Radio Corp. Cincinnati: Radio Supply Co., Cleveland: Radio Servicemen's Supply Co. Columbus: Hughes Patent Elec. Corp. Detroit: Standard Radio Parts Distributors Radio Specialties Co. Fort Wayne: Pemberton Electronics Hardware Stern Radio Parts Indianapolis: I. Hunkle Louisville: Harrison Radio Co. New York: Radio & Electric Service Philadelphia: Radio Shack Inc. Rochester: Bancroft, Inc. Toledo: Toledo Radio Specialties Co.

**NO BACK TALK
FROM**

Utah

TRANSFORMERS

The Result of 15 Years' Experience in the Design of Radio Parts

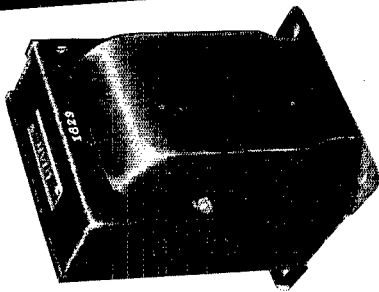

You get no hum or buzz from UTAH Amateur transformers. Perhaps you are accustomed to feed-back from output transformers in a class B circuit. But UTAH has eliminated that, just as UTAH has pioneered so many major improvements.

Like other UTAH parts, these transformers are mechanically sound. Their unusually high safety factor, in both design and insulation assures better performance and longer life. Coils are uniformly wound and carefully and completely impregnated. The larger units are additionally moisture-protected with pitch, and completely enclosed in close-fitting steel boxes.

There's one way to be sure of output transformers that don't talk back. Insist on UTAH. Your jobber has them.

UTAH RADIO PRODUCTS CO.

CHICAGO, ILLINOIS

BUENOS AIRES

(UGOA RADIO PRODUCTS CORP.)

**TORONTO
ONTARIO, CANADA**

15 YEARS OF LEADERSHIP

"AIR INDUCTORS"

Trade Mark

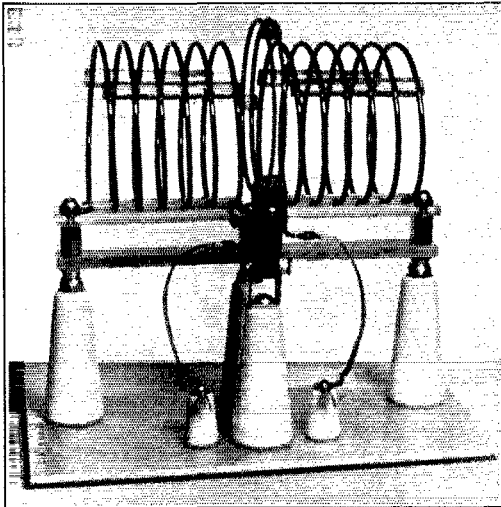

The New B & W SWINGING LINK ASSEMBLY is the practical solution to complete control of loading from the final stage to low impedance feeders. When used with our special antenna impedance matching coil it will work into either high or low impedance lines.

Most complete line of transmitting coils on the market

See them at your local jobber or write direct for catalog

BARKER & WILLIAMSON
RADIO MANUFACTURING ENGINEERS
ARDMORE, PENNA.

DO YOU WANT TO LEARN WIRELESS and TELEGRAPHY?



TWO BOOKS EVERY AMATEUR
SHOULD HAVE —

Send Now!

25¢
COIN, MONEY ORDER
OR STAMPS
Each
POSTPAID

Hundreds of amateurs have learned from these books, so can you.

These books give you the fundamentals of wireless and telegraphy. They contain the codes and how to learn them. Mail your order now to:

SIGNAL ELECTRIC MFG. CO., Menominee, Michigan

ESTABLISHED
1892



nessee bottoms. E. C. Frase, Jr., owner of W4FK was released from duty at WMC on January 20th and, with W4ADT, put the 20-meter 'phone rig on 3550 kc. with special F.C.C. 'phone authority. Hourly schedules were had with the boats U.S.S. *Yocana, Nolty, Stallings and Sequoyah*, on which U. S. Forest Service portables were installed. Schedules were also kept with Memphis amateurs who had carried emergency equipment to flooded regions, including N4AFI and L. N. Stevens, W4DEB, who took his rig to Dyersburg, Tenn., and maintained contact from there.

At Nashville W4CRE, operated by W. C. Montgomery, Jr., Walter Bearden, and L. H. Montgomery, members of the WSM operating crew, did a worthwhile job of relaying on 75-meter 'phone, useful in connection with the WHAS-WSM relay broadcast tie-up. From Chattanooga M. W. Buhrman, W4CBS, aided by Paul C. McCampbell, W4CDC, took a mobile station westward to the river, operating in the TVA-Forest Service net. Also working in Tennessee were W4APC 160, W4AXO 80, W4BLG 80, W4CBU 80, W4CVG 80, W4DIJ 80, W4DUD 80, W4LN 80, W4LU 75, and W4PL 80.

Entering the State of Arkansas, Philip B. Williams, W5EIP, skipped college a week and, aided by W5BKD, operated on 3.5 and 7 Mc. in Blytheville, one of the more critical areas. Somewhat further down, at Osceola, Wm. A. Steed, W4DKK, who had come from Memphis, with B. L. Myers of Mississippi, maintained 24-hour operation on 65-meter 'phone for traffic in that flooded region. R. M. Bailey, W4DOF/5, worked 80 in Osceola, as well. Still further down, at Helena, K. S. Wadlow, W5EKH, was on the job.

Over in Little Rock, S.C.M. Henry E. Velte, W5ABI, lined up a state QRR network. E. F. Henning, W5BMI, not only handled flood traffic but during the same period provided a three-day link between Little Rock and St. Louis for the telephone company when the simultaneous ice and sleet storm took their wires out, contacting W9EFC which was remotely-controlled by W9CMF; his emergency traffic total was 255. Wilfred Menees, W5BKX, participated in this work also. The National Guard station, AK6, of Little Rock, was manned by amateurs. Edward W. Logan, Jr., W5IQ/WLUB, handled much of the traffic coming through Little Rock from river stations. Ivan Wright, W5ENL, was the C.C.C. base station.

Other stations reported active in flooded regions along the river but without details, include T. M. Knight, N5FNT, relieved by W5FJY, who took an 80-meter rig to Wynne; E. L. Brown, W5EHO, who went to Jonesboro; D. J. Stickler, W5DZK, 160, Paragould; and Grady L. Hardin, W5CPV, Camden.

National:

Throughout the nation other radio amateurs served during the emergency period. Some of them served in nets, handling traffic into and out of the critical zones. Others served equally by just standing by, on the job if needed, meanwhile keeping the bands free of needless QRM.

New

CARDWELL DUAL TRIM-AIR LINE OF DOUBLE MIDGET CONDENSERS

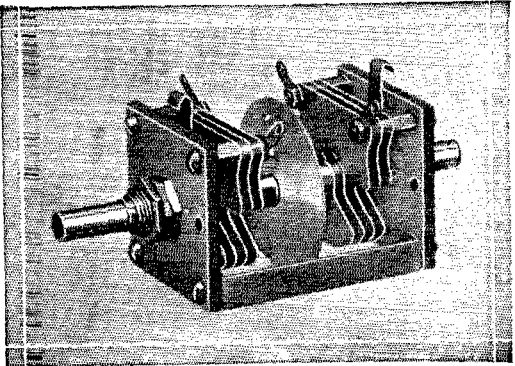
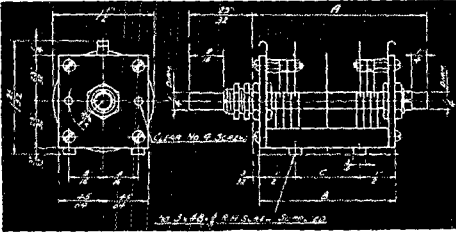

- Isolantite insulation.
- Double end plates.
- Sturdy heavy duty double bearings.
- Solid nickel plated brass shafts.
- New "TYANGLE" tie rods for maximum frame strength, yet simple construction.
- 1/4 inch shaft extended at rear for ganging to other units.
- Four convenient mounting methods:
 - A. Single hole.
 - B. Tapped holes in "Tyangle" rods.
 - C. Regular Trim-air mounting brackets.
 - D. Regular Trim-air mounting posts.
- Plenty of space between sections with shield optional.
- Five compact balancing types, similar except single bearing only.
- All types have exclusive Trim-air cup type blue steel "take up" washers, insuring one hundred percent permanent shoulder bearing tension.
- Light weight and small size makes these units ideal for portable gear.

ER-25-AD For push pull 5 and 10 meter buffer amplifiers, phasing controls on S.S. supers. and for portable gear of any type. Cap. 25-25 Mmids. 1000 volts. Net price **\$1.62**

ET-30-AD

A fine unit for ultra high frequency final amplifiers, filling your insistent demand. Cap. 30-30 Mmids. 2500 volts. Net price **\$2.16**

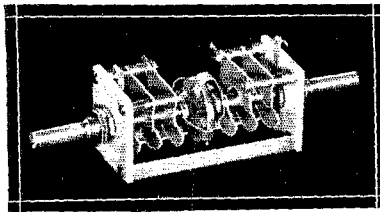
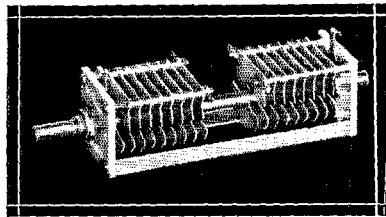

ES-4-SS

Used as shown, with Isolantite coupling, as single control neutralizer for push pull 35-T's etc. Available also with solid shaft. Net price **\$2.46**

NEW DUAL TRIM-AIR MIDGETS

Type	"A" Dim. (Depth Behind Panel)	"B" Dim.	"C" Dim.	Airgap List ins.	Price
ER-10-AD	2 11/16"	2 3/32"	1 3/32"	.030"	\$2.60
ER-15-AD	2 11/16"	2 3/32"	1 3/32"	.030"	2.60
ER-25-AD	2 11/16"	2 3/32"	1 3/32"	.030"	2.70
ER-35-AD	3 17/32"	2 15/16"	1 15/16"	.030"	2.90
ER-50-AD	3 17/32"	2 15/16"	1 15/16"	.030"	3.10
EU-75-AD	3 17/32"	2 15/16"	1 15/16"	.020"	3.30
EU-100-AD	3 17/32"	2 15/16"	1 15/16"	.020"	3.40
EU-140-AD	4 3/16"	3 19/32"	2 19/32"	.020"	6.00
ET-30-AD	5"	4 3/8"	3 3/8"	.070"	3.60
ET-30-AD	5 9/16"	4 3/8"	3 3/8"	.070"	4.10
(with insulated coupling)					
ES-4-SS	3 17/32"	2 15/16"	1 15/16"	.140"	3.60
ES-4-SS	4 3/32"	2 15/16"	1 15/16"	.140"	4.10
(with insulated coupling)					

EU-140-AD

For receivers of high "C" P.P. low voltage tank circuits. Cap. 140-140 Mmids. Net price **\$3.60**

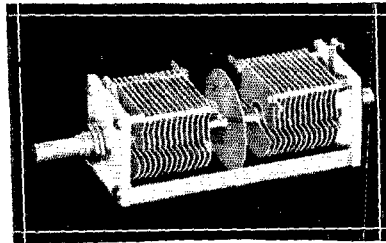

New Balancing Type Trim-Air Midgets

ER-25-AB	1 1/32"			.030"	1.90
ER-50-AB	1 5/16"			.030"	2.30
EU-75-AB	1 5/16"			.020"	2.50
EU-100-AB	1 13/32"			.020"	2.60
EU-140-AB	1 7/8"			.020"	5.30

See this new line at all CARDWELL distributors and get free bulletin.
 40% DISCOUNT on LIST PRICES SHOWN.
 Prices subject to change without notice.

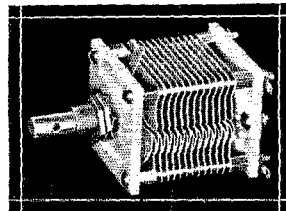

EU-140-AB Illustrates one of five sizes of new balancing capacitors. Very useful in bridge work. Max. Cap. either side, 140 Mmids. Net price **\$3.18**

THE ALLEN D. CARDWELL MFG. CORP.
 83 PROSPECT STREET • BROOKLYN, NEW YORK

Say You Saw It in QST — It Identifies You and Helps QST

Double Your Power!

At the Useful Voice Frequencies

Cut through QRM with a voice that can be understood. You don't need tricky high gain amplifier with this tremendously efficient voice microphone. Eliminates all RF feedback troubles with its "airtight" shielding. Cuts out your hum problems too. You'll get more satisfaction out of the dollars spent on a VT-73.



LIST —

- MIKE
- STAND
- PLUG

\$27.50

Write now for
bulletin 10-C

Model VT-73

THE TURNER COMPANY
CEDAR RAPIDS, IOWA

Licensed under patents of the Brush Development Company

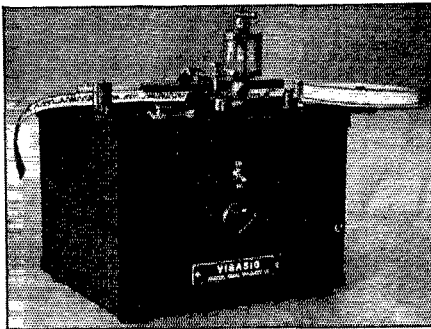

VISA SIG Full Automatic Siphon Tape Recorder

for Amateur and Commercial use

Will record code signals from the air up to and in excess of 100 WPM. Use it to make a record of your own fist or the fellow's you work. Make a permanent record from your receiver of weather reports, press news, speed contests, etc. See how it helps improve your fist!

VISA SIG — With electrically driven tape puller, constant level ink feed and 1500 ft. tape capacity, complete in one unit, \$59.00

PRICES F.O.B. NEW YORK CITY

Commercial Station Managers and Executives write for particulars of professional 200 WPM model

HAMS AND SWL! Write for complete information concerning our new audio oscillator in kit form. Every fellow interested in code speed needs one!

UNIVERSAL SIGNAL APPLIANCES

64 West 92nd Street

New York City

Visasig Blueprints \$1.00

The latter, of course, cannot here be credited; their silence makes them anonymous. Yet the heartfelt feeling of every amateur in the flooded sections is expressed in the statement that to them is owed much of the inspiring success of the present emergency work.

It is much easier to credit and thank those stations which were heard. Of particular value was the work of the monitoring stations or "vigilantes" appointed to disseminate the F.C.C. order and enforce its observance. Approximately 60 appointments were made, with the object of covering the country adequately and yet not introduce additional interference complications. That the selected stations did an efficient job will be attested to by almost any amateur along the Ohio Valley. The stations: W1APK 75, W1AW- INF 80, W1BDI 80, W1BFT 80, W1JFN 80, W1SZ 75, W1ZK-KBT 160, W2BGO 80, W2DC 75, W2DXO 80, W2HFB 160, W2HNP 75, W2HZY 80, W3NF 80, W3QV 75, W4APU, W4BNI 75, W4CQZ 160, W4CXY 80, W4DGS, W4DW 75, W4OG-NC 80, W5BHO 75, W5CEZ 80, W5CGI, W5DEJ 80, W5DXA 80, W5FPO 160, W5ZM, W6BIC, W6ITH, W6IUX, W6JRU 160, W6KFC 80, W6LMD 80, W6LPE 160, W6MQS 160, W7BSU 80, W7DUE 80, W7DXQ 75, W7FHB 160, W7NH 80, W8AOM 75, W8CSX 75, W8DXB 75, W8FIP 75, W8IAI 160, W8JIT 80, W8KWA 80, W9BUH 80, W9ELL 75, W9FA 80, W9IQI 80, W9IU 80, W9JZJ 75, W9KEF 75, W9KJY 80, W9OUD 80, W9SEB 80.

Other stations in the eastern half of the country whose work during the flood emergency has been reported: W1AKS, W1BDI, W1BQS, W1DAV, W1DCC, W1DVO, W1ET, W1GME, W1INF, W1IYG, W1ITX, W1JMJ, W1KBT, W1KHW, W1SZ, W1UE, W1WI, W1ZK, W2ALR, W2AZM, W2BBQ, W2BCX, W2BGO, W2BMG, W2BO, W2BXO, W2CFS, W2CJP, W2CTI, W2DBQ, W2DSH, W2DUP, W2DVP, W2DW, W2ELJ, W2EXR, W2FFT, W2FIJ, W2GGE, W2GSC (W2HAP), W2GSI, W2GZF, W2HZY, W2HGO, W2HMM, W2HMO, W2HSO, W2HUT, W2IAP, W2IJ, W2IJL, W2JNF, W2IOI, W2IRI, W2ISS, W2IUQ, W2IXJ, W2JET, W2JLQ (W2HAP), W2JPN, W2JVZ, W2JXS, W2KAX, W2KOO, W2OQ, W2PF, W2PHF, W2SC, W2ZX, W3AKX, W3BIP, W3BSO, W3BYA/WLQJ, W3CHH, W3CXL, W3DQ, W3DUI, W3ECA, W3EFM, W3EJ, W3EJH, W3EUG, W3FBR, W3FJU, W3FTK, W3FZ, W3FZK, W3GFI, W3GFM, W3GNR, W3GRT, W3SN, W3UA, W3ZN, W3ZY, W4AGS, W4AH, W4ANU, W4APU, W4BAQ, W4BBT/WLRI, W4BBV, W4CH, W4CLO, W4CUI, W4CVS, W4DLP, W4DW, W4DZS, W5ACF, W5ANT, W5BDX, W5BJO, W5BKD, W5BZG, W5CO, W5CRG, W5CYC, W5CWQ, W5DNU, W5DQ, W5EPY, W5FFI, W5FFK, W5FPO (W5DKR, W5AOZ), W8AAU, W8AKU, W8AOM (W8KYR), W8BMU, W8CMF, W8CSE, W8CSX, W8CV, W8FFN, W8FUG, W8GLL, W8GPE, W8GZQ, W8IIP, W8JMI, W8JYJ, W8KML, W8KZZ, W8LMI, W8MMV, W8MQX, W8NGC, W8NZO, W8OCH, W8OSV, W8OXI, W8PAT (W8PEQ,

(Continued on page 108)

BASES and DEMI- BASES

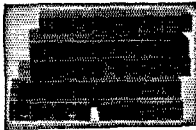

Crystalline finished of 20 gauge steel; each base is finished with bottom cover plate.

8 1/4 x 10 x 2.....	\$.70	10 x 17 x 2.....	\$1.10
8 x 17 x 2.....	.95	10 x 17 x 3.....	1.30
8 x 17 x 3.....	1.15	12 x 17 x 2.....	1.30
4 x 17 x 2.....	.70	12 x 17 x 3.....	1.40



GOING LIKE WILD FIRE

Our NEW LD-5 Mounted Crystals

These low drift plates, in the new LEEDS metal holder are outstanding from the standpoint of stability, accuracy, high output and low cost. Low Drift — 5 cycles per million per degree. Accuracy of calibration — better than .05%.

Orders filled plus or minus two kc. of specified frequency. Last but not least, the price of the mounted crystals, anywhere in the 160, 80 and 40 — \$3.50 meter band is only — \$3.50 Money back guarantee if you are not completely satisfied.

LEEDS type A.L. metal crystal holder, as illustrated above, fits standard 5-prong socket..... \$3.9c

LEEDS

Completely shielded High Voltage.

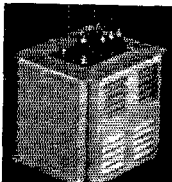

Transformer

Made for us by one of the most reputable manufacturers in this field.

300 MA
750-1000 v. each side..... \$5.70
1000-1250-1500 v. each side..... 7.35
1500-2000-2500 v. each side..... 11.95

Type P — 1200 v. C.T. at 200 ma; 5 v. at 3 amp; 2 1/2 v. at 10 amp; 7 1/2 v. tapped at 6.3 at 2 1/2 v. Special..... \$2.95

Thordarson Cased Transformer, 600 volts each side of C.T. 200 ma 2 1/2 v. 10 amps. C.T. 5 v. 3 amps. 7 1/2 v. \$2.45

Thordarson Choke, 12 H. 250 ma..... \$1.95
We carry the complete Thordarson line at 40% and 2% from list price.

LEEDS CHOKES IN METAL CASE SIMILAR AS ABOVE ILLUSTRATION

20 Henry Smoothing—5-25 H. Swinging
62-F 200 MA... \$1.75... 62-RS... 200 MA
62-G 300 MA... 3.25... 62-CS... 300 MA
62-H 400 MA... 4.00... 62-HS... 400 MA
62-I 550 MA... 5.50... 62-IS... 550 MA

AEROVOX OIL FILLED & IMPREGNATED CONDENSERS

1 mfd. 1000 v.. \$1.59	1 mfd. 1500 v.. \$1.67
2 mfd. 1000 v.. 1.97	2 mfd. 1500 v.. 2.30
4 mfd. 1000 v.. 2.85	4 mfd. 2000 v.. 2.09
	2 mfd. 2000 v.. \$2.79

Electrolytic and tubular condensers in stock

General Radio

Variacs and parts in stock

677-U coil forms, 21 turns, 2 1/4" dia. resonant on 3.5 mc. 100 mfd. cap. 50c
677-V — 30 turns 4" dia. resonant 1.7 mc. 100 mfd. cap. 75c

Wright DeCoster

Mokoil Dynamic Permanent Magnet Reproducers

Complete with Universal transformer, matches all output tubes.

5" Speaker —
No. 482..... \$2.41
6" Speaker —
No. 582..... \$2.91
8" Speaker —
No. 682..... \$3.41
10" Speaker —
No. 782..... \$3.91
12" Speaker —
No. 982..... \$4.91
All other types available. Price on request.



LEADS THE FIELD
World Wide Service to Amateurs

45 Vesey Street
New York City
Tel. Cortlandt 7-2612
Cable Address: "RADLEEDS"

Rack Panels by LEEDS



are furnished with black shrivel finish in the standard 19" length, 1/4" thick. Mounting slots are spaced according to Bureau of Standards specifications, insuring freedom from all trouble in mounting or interchanging panels.

Steel	Price	Width	Aluminum	Price
PS-1.....	\$.52	1 1/2"	PA-1.....	\$.74
PS-2.....	.57	3 1/2"	PA-2.....	1.03
PS-3.....	.68	5 1/4"	PA-3.....	1.30
PS-4.....	.71	7"	PA-4.....	1.55
PS-5.....	.95	8 3/4"	PA-5.....	1.90
PS-6.....	1.15	10 1/2"	PA-6.....	2.45
PS-7.....	1.30	12 1/4"	PA-7.....	2.90
PS-8.....	1.50	14"	PA-8.....	3.35
PS-9.....	1.70	15 1/2"	PA-9.....	3.70
PS-10.....	1.90	17 1/4"	PA-10.....	3.95
PS-11.....	2.05	19 1/4"	PA-11.....	4.45
PS-12.....	2.30	21"	PA-12.....	5.20

Masonite Crystalline finish panels, 3/16" thick, sizes as above, prices slightly lower.

NAVY TELEGRAPH KEY

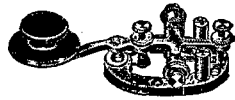

List \$3.60. Navy knob—1/4" Tungsten contacts. While they last.... \$1.15
With regular knob..... .95c

The New Sensational AMPEREX

Class B Tube, Type ZB-120. Completely described Feb. QST, page 77 \$10

HR-100..... \$12.50
HF-200..... \$24.50
HF-300..... \$35.00

NATIONAL CRM Oscilloscope

Employing a 913 RCA tube; net \$11.10 (without tube). RCA 913 tube..... \$5.60

NC 100—NC 100 X and 101 X

Hammarlund "Pro" and "Super-Pro"

Sold on time at cash prices in metropolitan area. No down payment.

Liberal allowance on your old set.

We carry the complete line of NATIONAL HAMMARLUND and GARDWELL.

The BULLET, T.R.-2 electro dynamic Microphone, made by Transducer Corp. Special..... \$23.23

Model T.R.-3. List \$24.50. Special..... \$14.70

Write for folder

TAYLOR Custom Built TRANSMITTING TUBES

T55 — 55 watt plate dissipation..... \$8.00
T155 — 155 watt plate dissipation..... 19.50
T200 — 200 watt plate dissipation..... 21.50
866 Mercury Vapor Rectifying tube..... 1.65
866 Junior..... 1.00

T-20 ceramic base, 20 watt plate dissipation, conservatively rated \$2.45

600 V. 100 mc. All other types in stock

RCA 806 tube — \$24.50. Complete line of RCA tubes in stock. Write for folder.

The record is 100% perfect. Thousands of microfarads of LEEDS OIL FILLED CONDENSERS are in use without one case of failure.

1 M F 1000 volt D.C. working.....	\$1.10
2 M F 1000 volt D.C. working.....	1.45
4 M F 1000 volt D.C. working.....	2.00
1 M F 1500 volt D.C. working.....	1.45
2 M F 1500 volt D.C. working.....	1.95
4 M F 1500 volt D.C. working.....	3.25
1 M F 2000 volt D.C. working.....	1.75
2 M F 2000 volt D.C. working.....	2.45
4 M F 2000 volt D.C. working.....	4.45
1 M F 3000 volt D.C. working.....	2.50
2 M F 3000 volt D.C. working.....	4.95

TRIMM 2000 ohm phones..... \$1.80
4000 ohm..... 2.25
DX 20,000 ohm imp..... 2.65

NOISE SILENCER ADAPTERS are a great help on reducing natural static too. LEEDS "QUIET CAN" and "SILENT CAN" also provide freedom from ignition noises and afford an ideal arrangement for push to talk phone and break-in CW.

LEEDS "QUIET CAN" for receivers with 2 1F stages; less tubes..... \$5.95

3 R.C.A. tubes..... \$2.65

LEEDS "SILENT CAN", for receivers with 1 1F stage; less tubes..... \$7.50
4 R.C.A. tubes..... \$3.35

LEEDS has the most complete line of Antenna Wire any length desired.

LEEDS CASED PLATE TRANSFORMERS

PRIMARY 115 VOLTS A. C. 50/60 CYCLES
LB-10 — 900V.C.T. at 150 MA; 5V-3A; 2 1/2V-10A..... \$3.25
LA-2 — 1000V.C.T. at 200 MA; 2 1/2V.C.T. 14A; 5V.C.T. 3A. 4.00
LA-3 — 1200V.C.T. at 200 MA; 2 1/2V-10A; 7 1/2V-3A; 5V-3A. 5.00
LA-4 — 800 each side of center at 150 MA..... 3.75
LA-5 — 800 each side of center at 250 MA..... 5.50

LEEDS SMOOTHING CHOKES
LB-1 — 12 Henry, 200 MA; D.C. resis. 140 ohms..... \$2.50
LA-30 — 12 Henry, 300 MA; D.C. resis. 105 ohms..... 3.75
LA-50 — 12 Henry, 500 MA; D.C. resis. 70 ohms..... 6.50

LEEDS INPUT SWINGING CHOKES
LB-2 — 5/25 Henry, 200 MA; D.C. resis. 140 ohms..... \$2.50
LA-40 — 5/25 Henry, 300 MA; D.C. resis. 105 ohms..... 3.75
LA-60 — 5/25 Henry, 500 MA; D.C. resis. 70 ohms..... 6.50

Leeds Cased Filament Transformers

PRIMARY 115 VOLTS A. C. 50/60 CYCLES
LA-15 — 2 1/2V.C.T. 12A; 5000 V. insul. 10V.C.T. 6 1/2A..... \$4.00
LA-16 — 5V.C.T. 20A; 7000 V. insulation; LA mtg..... 3.75
LA-17 — 5V.C.T. 20A; 10000 V. insulation; LA mtg..... 5.00
LB-12 — 2 1/2V.C.T. 12A; 7000 V. insulation; LB mtg..... 2.25
LB-13 — 1 1/2V.C.T. 6 1/2A; 5000 V. insulation; LB mtg..... 2.50
LB-14 — 10V.C.T. 6 1/2A; 5000 V. insulation; LB mtg..... 2.50
LB-15 — 5V.C.T. 3A; 5V.C.T. 6A; 5000 V. insul..... 2.50
LB-11 — New heavy duty half shell 950V.C.T. at 250 mils; 5V. at 3 amp; 2 1/2V. at 3 amp; two 6.3V. at 4 amp..... 6.00

Leeds Fully Mounted Channel Frame Chokes

CF-022 — 12 H. 125 mil..... \$1.75
CF-025 — 10 H. 300 mil..... 2.25
CF-026 — swinging 5-20 H. 300 mil..... 2.25
LT-1 Pri. 115 A.C. Secondary 2 1/2 V.C.T. 3 A..... .65
LT-2 Pri. 115 A.C. Secondary 6 1/2 V.C.T. 1.2 A..... .65
LT-3 Pri. 115 A.C. Secondary 2 1/2 V.C.T. 6 A..... .75
LT-4 Pri. 115 A.C. Secondary 6 1/2 V.C.T. 2 A..... .90
LT-5 Pri. 115 A.C. Secondary 2 1/2 V.C.T. 10 A..... .90
LT-6 Pri. 115 A.C. Secondary 5 V. 3 A..... .90
LT-7 Pri. 115 A.C. Secondary 7 1/2 V.C.T. 3 A..... .90

COTO-Coil Low Loss Inductors

We have them for immediate shipment

Raytheon Transmitting Tubes

RK-10.....	\$3.50	RK-28.....	\$38.50
RK-15.....	4.50	RK-30.....	10.00
RK-16.....	4.50	RK-31.....	10.00
RK-17.....	4.50	RK-32.....	12.00
RK-18.....	10.00	RK-34.....	3.50
RK-19.....	7.50	RK-36.....	14.50
RK-20.....	15.00	RK-100.....	7.00
RK-21.....	5.00	841.....	3.25
RK-22.....	7.50	842.....	3.25
RK-23.....	4.50	866A.....	5.00
RK-24.....	2.25	872A.....	18.50
RK-25.....	4.50		

WRITE FOR FOLDER

MR. E. H. RIETZKE



PRESIDENT OF CREI

ARE YOU TRAINING OR WAITING FOR TOMORROW?

**New Equipment . . . New Problems Will
Demand Men with MODERN Training**

There is no mystery as to what "tomorrow will bring." Already we have seen highly complicated receivers. Facsimile transmission is HERE. Television is not far off! Men who want to get ahead in Radio will find that NOW is the time to insure their future by increasing their ability. CREI home study courses are *practical*, and have been thoroughly tested and proved in all branches of Radio.

**Write Today for "A TESTED PLAN
for a Future in Practical Radio Engineering"**

This FREE Informative and illustrated booklet will prove helpful to men not satisfied with their present positions in Radio. Write for your FREE COPY TO-DAY!

**CAPITOL RADIO
ENGINEERING INSTITUTE**

Dept. Q-4

WASHINGTON, D. C.
14th and Park Road

NEW YORK CITY
29 Broadway



How Old Is Your LICENSE MANUAL?

You know that the F. C. C. makes frequent changes in amateur regulations? That many of these changes deal with the rules for getting new licenses and renewals? That when the regs are changed, the appropriate questions are changed in the license examination, and the answers have to be different?

▶▶▶▶ To keep pace with these changes, The Radio Amateur's License Manual is frequently revised. It is now in its seventh edition. Moreover, each copy is, when necessary, accompanied by a change sheet summarizing any changes that have been made since it went to press. ▶ The License Manual is as invaluable to the practising amateur as it is to the aspirant—but only if it is the current edition. **Price 25c postpaid**

**American Radio Relay League
West Hartford, Connecticut**

The Maxim Memorial Relay

(Continued from page 8)

the higher frequency bands, especially 14 and 28 Mc., could not be expected to yield as much coverage as daylight operation on the same frequencies. The coverage reports, when analyzed, show that the listeners responded to the message as sent on the various frequency bands, in the following percentages: Telegraph listeners, 55.6% 3.5 Mc., 42.2%; 7 Mc., 11.2%; 14 Mc., 2%; 28 Mc., .2%. 'Phone, 44.4%: 1.7 Mc., 11%; 3.9 Mc., 14%; 14 Mc., 10.4%; 28 Mc., 1.3%; 56 Mc., 7.7%. The transmission conditions, band occupancy, and the number of transmitting stations in each band, as well as the individual response factors, of course, determine the participation. Since 'phone is ideally adapted for broadcast transmissions, and more 'phone than telegraph operators were given the president's message to transmit, a 'phone response superior to telegraph might have been expected, but the relative numbers of the listeners, of course, comes into the picture too. At any rate the coverage in both groups was highly satisfactory.

Operating on both 'phone and c.w. was "snappy" and well conducted, in general. Some 'phone traffic was started with incomplete preambles or with the form different than standard message form. It strikes us that some organized 'phone nets, with interesting practice in handling of record communications and accurate writing down of messages would be an excellent thing. This can be accomplished through training with A.A.R.S. or right within our own organization, if 'phone operators generally will call upon their P.A.M. or S.C.M.'s (and work with them) to bring about periods of such planned operating. The relay did its part in providing point and incentive to radio operating, and all concerned express interest in having more of the same.

The relay messages were largely received by effort of individual Connecticut operators, that is, there was less work by individual operators outside Connecticut in collecting traffic and passing it along in bunches than in the last relay. Some of this took place, however, but more individuals wanted to send their messages direct to a delivering station than in the past relays. In another relay we believe that we should ask more mid-western stations who transmit to also act as collecting stations.

The results obtained by your Headquarters station, W1AW, in its initial operation under this call, will be of interest. 28% of all listeners acknowledging receipt of the official message, copied one of the three W1AW transmitters, plate inputs to which were (in the temporary location) but 210, 375 and 100 watts respectively for the 3.5-, 7- and 14-Mc. sets. The 181 reports divided 75%, 18.8% and 6.2% respectively for these three bands. The higher frequency brought acknowledgments from Germany (D4TKP via W3CSY) and Barbados (VP6MR via W1AMP) as well as from the west coast, Florida, Minnesota, etc., in this country.

(Continued on page 10E)

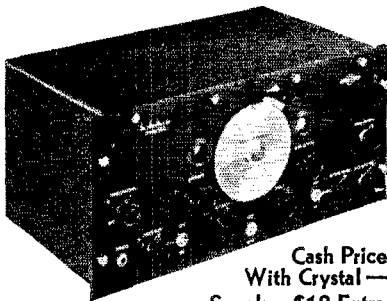

ONLY
\$19.50
DOWN
Balance
\$7.30 Per
Month
1 YEAR
To PAY

Cash Price **\$99.50**
With Crystal —
Speaker \$12 Extra

Hallicrafter New SX11 SUPER SKY RIDER

THE NEW 1937 SUPER SKY RIDER — Now with 11 tubes — even finer performance and added features. A new high fidelity power output (17 Watts Max.). The "perfect" receiver for the amateur.

11 Tubes — 10 of them metal, 40 M. C. to 535 K. C. in 5 Bands, 338 degree main tuning dial, Electro-Mechanical Band Spread, 14 Watts Undistorted output, Direct Calibration Tuning — No Charts or Tables, Field Strength Indicator — Magic Eye, Improved 10 Meter Performance, Single Signal Crystal Action, 465 K. C. Iron Core I. F. for improved selectivity, Ceramic Insulation, Illuminated Dials, Full AVC.

Speaker \$12.00 Extra

NOW! Lower Down Payments Than Ever Before! EASY TERMS

These receivers are among the best values money can buy. Our 6% EASY CREDIT PLAN makes it easy to own one. Compare our rates! Send down payment with your order today. Set will be shipped as soon as credit is O.K.'d. Entire transaction 1 week. Order now!

	Cash Price	Down Payment	6 Months Payments	9 Months Payments	12 Months Payments
HAMMARLUND SUPER PRO speaker	\$255.70	\$35.70	\$38.08	\$25.78	\$19.64
NATIONAL NG-100 complete with tubes and speaker in cabinet.	\$125.10	\$20.10	\$18.58	\$12.50	\$9.47
NATIONAL NG-100X complete with tubes, crystal and speaker in cabinet.	\$142.60	\$27.60	\$21.10	\$14.21	\$10.80
NATIONAL HRO with tubes and coils.	\$129.00	\$24.00	\$18.58	\$12.50	\$9.47
NATIONAL HRO with tubes, coils and power supply.	\$179.70	\$29.70	\$26.14	\$17.67	\$13.45
ACR-155 complete with tubes and built in speaker.	\$195.60	\$35.60	\$27.84	\$18.83	\$14.33
ACR-175 complete with tubes, crystal and separate speaker.	\$74.50	\$14.50	\$11.00	\$7.39	\$5.92
RME-69 complete with tubes, crystal and speaker in cabinet.	\$119.50	\$19.50	\$17.74	\$11.93	\$9.02
HALLICRAFTER SX-11 complete with tubes and crystal. Speaker \$12.00 extra.	\$151.20	\$26.20	\$21.94	\$14.77	\$11.25
HALLICRAFTER ULTRA SKYRIDER with tubes and crystal. Speaker \$12.00 extra.	\$99.50	\$19.50	\$14.36	\$9.66	\$8.59

NEWARK HAM BARGAIN

Newark Ham Bargain in Plate Transformer and Chokes to Match. These Transformers and Chokes are fully enclosed in silver finish. All Guaranteed. You can now build that new Rig at a much lower cost.

Manufactured by UTC

- 20462A — 750-1000 each side of center, AC, at 300 mills. \$5.70
- 20462B — 1000-1250-1500 AC each side of center, 300 ma. \$7.35
- 20462C — 1500-2000-2500 each side of center, AC, at 300 mills. \$11.95
- 20462D — 1000-1250-1500 AC each side of center, at 500 mills. \$11.75
- 20462F — Smoothing choke 20 hy. — 200 MA — Lug terminals. \$1.75
- 20462FS — Swinging choke 5-25 hy. — 200 MA — 2500 volts — Insulation — Lug terminals. \$1.75
- 20462G — Smoothing choke 20 hy. — 300 MA. \$3.25
- 20462GS — Swinging choke 5-25 hy. — 300 MA — 3500 volts — Insulation. \$3.25
- 20462H — Smoothing choke 20 hy. — 400 MA. \$4.00
- 20462HS — Swinging choke 5-25 hy. — 400 MA — 500 volts — Insulation. \$4.00
- 20462I — Smoothing choke 20 hy. — 550 MA. \$5.50
- 20462IS — Swinging choke 5-25 hy. — 550 MA — 600 volts — Insulation. \$5.50

Variatch Modulation Transformers

- VM-1. Will handle any power tubes to modulate a 20 to 60 watt class C stage. Maximum audio output 30 watts. \$4.70
- VM-2. Will handle any power tubes to modulate a 40 to 120 watt class C stage. Maximum audio output 60 watts. \$7.35
- VM-3. Will handle any power tubes to modulate a 100 to 250 watt Class C stage. Maximum audio output 125 watts. \$11.76
- VM-4. Will handle any power tubes to modulate a 200 to 600 watt Class C stage. Maximum audio output 300 watts. \$19.11
- Thordarson No. T6878 Plate and Filament Transformer, 600-0-600 V. at 200 MA, 2 1/2 V. at 10 amp. 5 V. at 3 amp. 7 1/2 V. at 3 amp. \$2.45
- High Voltage Transformer, 1000-750-500-0-500-750-1000-300 MA. 3 1/2 x 4 1/2 x 5 1/2. \$5.95

DON'T WAIT until you can receive cash. Buy now on easy credit, at today's prices. Your saving will more than offset the small cost of our low rate 6% credit plan. Prices have already advanced about 20% during past month and are sure to go much higher! Prices guaranteed for this month only!

VERY SPECIAL OIL FILLED AND OIL IMPREGNATED FILTER CONDENSERS

Lucky Purchase of 10,000, all well known makes, enables us to offer astonishing low prices. All Guaranteed at rated voltages. Already sold down to limited supply and going fast. Order now!

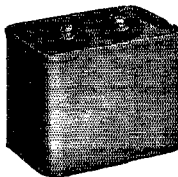

Cap.	Voltage	Size	Weight	Price
1 mfd.	2000 V. DC 5	3 3/4 x 1	1 1/4 lbs.	\$1.25
2 mfd.	2000 V. DC 3 1/2	3 3/4 x 2 3/4	3 lbs.	1.50
8 mfd.	2000 V. DC 5 1/2	3 3/4 x 4	4 lbs.	2.75
9 mfd.	3000 V. DC 5 1/2	3 3/4 x 11	9 lbs.	7.25
(including 2 1/2" bakelite standoffs)				
4.4 mfd.	1500 V. DC 5	3 3/4 x 1 1/4	1 1/4 lbs.	1.75
5 mfd.	1500 V. DC 3 1/2	3 3/4 x 1 1/4	1 1/4 lbs.	1.90
5.2 mfd.	1500 V. DC 5	3 3/4 x 2 1/4	2 1/4 lbs.	2.00

Use the 10 mfd. for perfect filtering in class B modulation Power Supply.

Filament Transformers

If you like to save money on quality merchandise here's some real bargains.

- 2.5 Volts, 10 Amps — 2500 Volts Insulation—No. 2510. \$0.95
- 6.3 Volts, 3 Amps — 1600 Volts Insulation—No. 63S. \$0.95
- 7.5 Volts, 3 Amps — 1600 Volts Insulation—No. 75S. \$0.95

CHOKES

- 18 Henries, 125 M.A., \$1.15
- A real quality choke. Resistance 130 Ohms. No. NS115. \$1.15
- Thordarson No. T6877 Heavy Duty Choke, 15 henries at 250 MA. \$1.95

At Last

Just Released by **TAYLOR!**

Tubes

- T20. \$2.45
- 866 Jr. 1.00
- 866. 1.65
- 756. 4.95
- 203B. 7.50
- 203A. 12.50
- 817. 18.50
- 822. 18.50
- T200. 21.50
- T55. 8.00
- T155. 19.50

Complete Stock RCA Transmitting Tubes in Stock

- New 806 \$24.50
- 807 2.90
- 913 5.60

Bliley Crystals

- BC3. \$3.95
- LD2. 4.80
- HF2. 6.50

EIMAC

- 35T. \$8.00
- 50T. 11.50
- 100T. 13.50
- 150T. 20.50
- 250T. 24.50

Added To Our Technical Staff
Hany Harrison W9LLX
Leo B. Wilcox W9BHM
Write to them about your problems.

NEW
Time Payments on parts and tubes totalling **\$60.00** or more.
WRITE FOR DETAILS

ORDER DIRECT FROM THIS AD—NOW

Receivers listed in this ad are best values anywhere. Order today on EASY TERMS. Send your down payment with order. Set will be shipped immediately upon approval of your credit. Entire transaction in 1 week. No red tape. Full details of any item, with complete NEW CATALOG FREE upon request.

FREE!
Write TODAY for New Bulletin of parts, tubes, and accessories. Just off Press.

NEWARK ELECTRIC COMPANY

226 W. MADISON ST. Dept. Q CHICAGO, ILL.

Station Activities

(Continued from page 64)

NEW ENGLAND DIVISION

CONNECTICUT—SCM, Frederick Ellis, Jr., W1CTI—INF leads the field this month with UE a close second. INF now signs AW. JXP, member of the Humdinger Net, says his net is now interlocked with the Haywire Net. HSX is the most active traffic man in New Haven. R.M. AFB keeps Trunk "C" traffic moving. ITI had his rig on exhibition at the Hartford Public High School Physics Exhibition, where it was one of the main attractions. IMV is looking for 1.75-Mc. 'phone men to join A.A.R.S. Net on that band and applies for O.P.S. IKE says, "Sure like the N.C.R.—and also the Nutmeg Net—it fills a big gap." CTI has been sick (more or less) and is still under doctor's orders. GME is an active member of the Nutmeg Net. GVV schedules 3FTK and 11OR. GKM was visited by VE2BU. GTX had to QRT radio and plug at studies. APW holds down the Bridgeport Section for the Nutmeg Net. INP is N.C.S. of the Saturday night Nutmeg Net and has a nice bunch there. Why not join in with them Saturday nights and increase the Saturday Net's roll call? HPI wants to buy a Dural rod or pipe about 70 feet long; there is a nice one at the Darien Police Station, but guess it isn't for sale. Hi, JLL expects to give 14 Mc. a whirl with a flock of 6L6's. HYF gives code practice to some of the gang at C.B.A. Keep it up, Rog. GC would like to use 'phone, but gets out better on c.w., so sticks to c.w. KFN says 21YH/1 is in town and will be with us in the net soon. BDI has an all-band 'phone-c.w. emergency rig using an 89 and 807. BIH does good work in the net. KED has been picking up stray traffic on 7 Mc. and schedules JXP. HXZ keeps Danbury on the map and in the net. Old reliable TD never fails to send in a report. DOW is working nights, 4 p.m.—12 mid., so nothing doing on net. After a couple of years CUH breaks down and buys a penny post card and sends in a report. Keep it up, Mel. AFG has 6L6 on 14 Mc. with 6 watts input; best DX HB9. DWP is our most active O.P.S. and reports every month. BNB says his 8-tube receiver works and hopes for traffic. EAO was first station to contact the new 1AW. You may all congratulate yourselves for your fine work in the Feb. 17th—18th relay. All Connecticut stations did a fine job. Many thanks, gang. We will have a QSO party soon just for ourselves to celebrate. BGC is back on 7 Mc. after being inactive for several years!

Traffic: W1INF 356 UE 331 JXP 299 KV 226 (WLG1 35) HSX 196 AJB 194 (WLG 77) AFB 178 ITI 166 IMV 126 DMP 126 JMY 118 IKE 116 FAJ 94 APZ 65 CTI 64 GME 51 GVV 45 YU/FRK 38 GKM 35 GTX 29 APW 28 FE 27 INP 25 DLX 22 HPI-JJL 17 HYF-GC 16 KFN 15 BDI 14 BIH-KED 11 HXZ-TD 9 DOW-CUH 3 AFG 2 DWP-BNB-JUD-JTD 1. W1ES 20.

MAINE—SCM, John W. Singleton, W1CDX—1ST leads the list this month with fine total. GOJ is keeping his Section humming in fine style. INW is right up among the leaders as usual. HSD has fine new rig. IBR reports new ham, IUM in Bridgewater. IVV is about ready to go with new antenna. IKC has worked 11 countries and 35 states. KLQ is new ham in Wilton. KKB is new ham in Belfast. CRU, CBU, GQ and HWX are active on 56 Mc. ASG and BJV have combined, and put a 1.75-Mc. 'phone on the air. BX is building a '10 job for every band. The S.C.M. has moved to Peaks Island, Portland, Maine, so send your reports to the new QTH in the future. The totals this month represent the standing at the end of the first month of the Section Traffic contest. Be sure your report is in on time in order to count.

Traffic: W1IST 236 GOJ 161 INW 136 HSD 34 CDX 30 IBR 18 IVV 7 IKC 3 DHH 2.

EASTERN MASSACHUSETTS—SCM, Albert N. Giddis, W1ABG—AKS handled a bunch of flood traffic on 7 Mc. IWC keeps Section Net moving. BEF is worrying over 28-Mc. 'phone. KH likes the National small oscilloscope. BFR worked FA8IH on 3.5 Mc. HXE sends code practice every night at 7 p.m. on 56 Mc. HKK works some 28-Mc. 'phone. KBQ is building mobile apparatus. JZU has 100 watts on all bands. FDB comes back on 3.5-Mc. c.w. IVX has a T-20 in final. JXO works 56-Mc. portable. JAS got a call from MacKay Radio although his transmitter was dismantled at the time! Guess these Commercial ops aren't so hot copying thru ham QRM! AKE is on 4-Mc. 'phone. IIM is busy with N.E. Council organization. IQH has new NC101X. JJY is enjoying 1.75-Mc. 'phone. WV had visit from D4BIU. JMW is new 56-Mc. station in No.

Chelmsford. ANM is "on the beach" again. DYC has beam on 56 Mc. DFF is on second trip to Mediterranean. QW and HCH contacted K5AC and G2TM on 3.5 Mc. HXE and JED are trying 3.5 Mc. ASE, ALP and KBO are engaged in the great ham activity-rebuilding. DSO is changing over SW4 for a.c. operation. JZN asks how to make crystals oscillate! DMF says QST shouldn't show such good-looking rigs which give him the rebuilding bug right in the middle of the traffic season! Amen.

Traffic: W1AKS 739 IWC 376 HWE 298 FRO 275 AGX 246 DDE 235 QA 230 ABG 200 FMG 122 EPE 112 BEF 111 KH 90 BMW 68 JNU 65 ILN 49 QW 43 EPZ 41 BFR 36 HXE-HKK 33 ZQ 34 (WLMQ 73) KBQ 28 RE 24 IIC 18 JZU 16 HCH 14 FDB 18 IYT 10 IVX-JXO 6 JAS-ASI 5 HWZ 4 HKY 3 ALP-LJ 2 JXU-EVE 1. W1DDE (WLG 70).

WESTERN MASSACHUSETTS—SCM, William J. Barrett, W1JAH—IOR reports IOC and KAW as moving to Chicopee Falls. Welcome to West. Mass. IOT and IOR make B.P.L. on deliveries. Nice going. IDG is prospective O.R.S. IZW comes through again. ZB raised DX total to 92 countries, and handles traffic with K5AG and WCFT. BKG is building a 6L6-ten rig for 14 and 28 Mc. JAH tries 3.9-Mc. 'phone between traffic schedules. BVR attended P.R.A. banquet at Providence, Feb. 13th. Perce is considering a portable rig for 1.75-Mc. 'phone. HSK is interested in 1-watt 'phone rigs. EOB lost an RK-20 but still has that '04 on shelf. GUO confines activities to A.A.R.S. drill and ragchews. HJR reports very regularly from Indiana; he has suitcase portable 14-Mc. 'phone perking and keeps schedules with the folks at home. IIP wants schedules. COI observes you can't run a 'phone and rebuild it at same time, so for a change he is running it. BNL has 7-Mc. ant. perking at new QTH. Our Section still needs plenty of reliable traffic handlers, and more activity out of those we have. Hi. How about some of you 'phones lining up with O.P.S.? For details write the S.C.M. or QSO GZL on 1.75-Mc. 'phone, or COI and JAH on 3.9 Mc. Let's get going. 73.

Traffic: W1IOR 290 IOT 230 IDG 209 IZW 195 ZB 29 BKG 47 (WLG 6) JAH 32 BVR 26 (WLG 175) AJD 84 HSK 22 EOB-GUO 20 ARH 19 IJR 11 HJR-1SN 6 JOP 3 IIP 1.

NEW HAMPSHIRE—SCM, Carl B. Evans, W1BFT—The NHEN drill on 3840 kc. this month worked out nicely for a starter using the new net procedure. There is quite a demand to have it more often, so we probably will increase drill to bi-monthly, on the first and third Sundays of each month. You fellows not on spot frequencies who want to get in on this, look for IP on 3812 kc. who will contact all those not on the regular nets. CEA has three crystals with QRM on them all. ANS is back on 3.5-Mc. c.w. for a change. JEH is still on 7 Mc. trying for W.A.S. EAL sent lots of news this month. CBJ is coming back on the air after a year's lay-off. ADR is still on 28 Mc. JNC is moving to Concord. CPM is rebuilding. IMB needs only six more states for W.A.S. EDN has a new rig with 59 e.c. oscillator. DUK now has a single ten on 3.5 Mc. JCA won a crystal at the last meeting of the M.V.A.R.A. for his code-copying ability. BFT has completed W.A.S. on 7 Mc. AVL has a new 101X. AVG is building a new receiver and is open for suggestions. AVJ threw (actually!) out his 6L6G exciter unit and is now using an RK39. HJI is back on the air and worked ZB1P on 7 Mc. HJM is attending radio school in Boston. IDY is on both 56 and 28 Mc. JSL's high power is a little too much for the local power company's hook-up to his house. GKE is planning to put in push-pull parallel '52's now to boost Concord's first real "California Kilowatt."

Traffic: W1WFL 770 (W1GB 37) IP 343 BFT 185 GMM 74 IDY 73 ITF 47 EAL 30 CEA 20 JDP 17 HJI 4.

RHODE ISLAND—SCM, Clayton C. Gordon, W1HRC—The P.R.A. had its annual dinner and get-together at the Port Arthur Restaurant in Providence at 8 p.m., February 13th; it was the most successful in years, from the point of satisfaction to those attending. Hamdom's old reliable friend, John Reinartz, W1QP, was the principal speaker, and, with the aid of Mrs. Reinartz to tell him geographical locations, he entertained the ladies as well as the dial-twisters with his stories of the trips across the Continent on his vacations. Percy Noble, W1BVR and our Director was there, as our other guest of honor, and spoke briefly regarding the affairs of the League, proving that he can recognize the time to talk and the time to let the other fellow do the talking. W1HRZ represented W1AQ's gang at the party. W1IEG (W1GK) has been nominated from Rhode Island for the Maxim Award for 1936. GTN has started construc-

tion of a second 50-watt transmitter to stand side by side with present one. QR-(WLGW) is busy with A.A.R.S. work. INU offered a prize of an overnight case, fitted with toilet articles, for the A.A.R.S. member in N.E. originating the most traffic during January—won by JEZ, of the 56-Mc. Net. KCS is now known to his friends as "The Baron." JYF has gone off 56 Mc.—antenna trouble—his mother decided to put the curtains back on the rods. The Westerly gang is composed of BOS, IEJ, BDS, IJK, AGJ, KGC and INN. BOS and IJK are on 1.75-Mc. 'phone. IEJ is on 7 Mc. with '03A. AGJ is having tough time with a 14-Mc. crystal. INN is trying to get 1.75-Mc. 'phone going. Woonsocket is in midst of conflagration—ESZ burnt out an '04A; LOL burnt out two '66A's and an '03A; JFK burnt out ten 280's and two 81's, and IHW burnt out 83 and Triplet meter. IYL and CDI now live in Woonsocket. BLV is at sea as radio op. JYT has new freq. meter. News from Newport finds HJ made W.A.C. after 13 years trying and then, inside of a month, W.A.C.'d seven times; his DX for January included U9AF, U9MI, U9ML, U9AW, JBCX; with the help of JNO his "super-crystal" 807 P.P. T-55 transmitter now goes FB on 7, 14 and 28 Mc., and they hope it will soon give 250 watts crystal-controlled on 56 Mc. BVI gets out better on 1.75 than on 3.9 Mc. JNO is getting out FB on 14- and 3.9-Mc. 'phone and is now a member of the R.C.C. HPE is still on 28 Mc. JFF has new FB7A and 89-802 transmitter. JNO reports U9AW as 14,330 kc. with T9 sig. and to be heard around 6 p.m. E.S.T. JAR and HRZ are prominent on 28 Mc. HRC on Feb. 14th received W5's and W6's on 28 Mc. on an S.R.R. on horizontal 8-foot rod, total height above ground 1 foot, with exceptional loud-speaker volume all afternoon and part of evening. JUG on 14-Mc. 'phone is employed at Rhode Island State Institutions in Howard (very appropriate call). IPU is on 56 Mc. again from new location in Cumberland, R. I. HEH has HF-100 on 28 Mc. with 100 watts, and believes from his tests that a 28-Mc. antenna ought to be vertical with the bottom exactly 1/2 wave above ground. DTZ has new band-switching rig with 4 bands available. HJB has the 56-Mc. Army Net under control. IZO built QP's crystal substitute, but had job hitting the band with it. The 56-Mc. bootleg situation has been getting rather bad again, but GTN is out after them and "it won't be long now." Tolerance towards bootleggers by hams is decreasing around here, and we are glad to see the hams taking this new attitude. See you all at the Convention at the Biltmore in May.

Traffic: W1IEG 262 (WLGK 30) GTN 164 QR 83 (WLGW 21) IQF JNO 1.

VERMONT—SCM, Alvin H. Battison, W1GNF—C.R.M.: 1FSV. R.M.: 1EZ. P.A.M.: 1A VP. FSV, IRO and GAN visited 8NSO at Fort Edward, N. Y. AHN and GNF visited the new airport radio installation at White River Jet. GAN is using two T55's. AAK's 28-Mc. signal is very consistent in Hawaii and Europe. EZ reports conditions on 7 Mc. very unusual. GVJ spoke on amateur radio at the Arlington Men's Brotherhood. JRU and IQG have new SW3's. GAE applied for membership in the A.E.C. BD is constructing an emergency-powered portable transmitter. JVT joined the A.A.R.S. HEV is a new amateur in Windsor. ERJ is making 16-mm. movies. KJG, ex-CBT, wrote a fine amateur radio article for the Morrisville paper. BJP has worked 72 countries; he visited DQK and JZF, had visits from JZF, IQG, KJG, CGW, TJ, JRU and 2EA. DQK worked his first DX on 28-Mc. 'phone. BLC is contemplating adding a new receiver. JZF is having trouble with his transmitter. ELR added a 35T buffer. FPS and GAE are now members of the R.C.C. ATF is again keeping A.A.R.S. schedules.

Traffic: W1FSV 239 GNF 48 AVP 33 GAE 18 GVJ-AHN 1.

HUDSON DIVISION

EASTERN NEW YORK—SCM, Robert E. Haight, W2LU—ISQ worked his first W6 on 3.5 Mc. LU is on 3530 kc. 9 p.m. daily. HYC was set up for O.R.S. party with e.c. osc. JKT on 14 Mc. worked "G," "CM" and lots of W9's. HAN wants interested hams for 56- and 3.5-Mc. Traffic Net. JWT reports Traffic Net working from 7 to 7:15 p.m. with JWT, HAN, JAN, JRG, IMY. HVR is trying for W.A.S. CC worked 5 continents in 3 hours, Feb. 12th. The E.N.Y. Section extends sympathy to UL upon the passing of his father. CJP guarded 8KYR's freq. during flood QRT. JAX is still on 56 Mc. HNH has 10 A.M. schedule, Sundays, with 1JMH. JSL, new O.R.S., is on 3.5-Mc. c.w. and 56-Mc. 'phone. CYW holds car license 1A-73-88; he is erecting directional 56-Mc. ant. ALP-9 used equip-

ment as listed in A.R.R.L. Emergency Corp for flood work (Red Cross, Military and State Police, refugees) in Evansville and Jefferson, Ind.; ACB was also with ALP. Congrats on arrival of new baby at ACB's shack. IUR has FB new rig 1/4-kw. input. BDB worked HUM portable in Florida on 7 Mc. KFB reports with FB letter. KGD is new ham at Larchmont, KFA new man in Port Chester. KFB raised skywire to 75 ft. for DX contest. HON visited G.E. factory and looked up the S.C.M. AZX is working for Arcturus Tubes and is in business with Burns-Hausser Lab. HON was elected Mayor of Y.M.C.A. Dormitory. JJS (not JSS) bats for ISQ at times. BJX sends the following news from the Mid-Hudson Amateur Radio Club: GWY and GFD are building 56-Mc. transmitters and receivers galore. DOS uses P.P. '10's in the final on 3.5 Mc. DWO works 3.5 Mc. with a pair of '45's in T.P.T.G. circuit. KGU, brand-new license just received by Gerry Livingston, will use pair of '46's in last stage on 3560 kc. JKT uses 70 watts in final 6L6—on 7 Mc. all day long, every day. CVT has 150 watts in final P.P. '10's on 7 Mc. EOD, formerly of Brooklyn, is now living and working in Poughkeepsie; he works 3.9-Mc. 'phone and 3.5-Mc. c.w. consistently. JSL received commendatory letter from Secretary of the Navy on recent Navy Day broadcast copy. BJX QSY'd to 7120 kc. to try a "hill" DX. CGT is on the air with a whole new transmitter, with T-200 in final. CDM, local high-power man, works the world on 7 and 14 Mc. with 750 watts punishing T-155 in last stage.

Traffic: W2ISQ 154 LU 153 HYC 125 JKT 23 HAN 20 JWT 15 HVR 14 CC 11 UL 9 CJP 5 JAX 3 HNH 2.

NEW YORK CITY AND LONG ISLAND—SCM, E. L. Baunach, W2AZV—Congratulatory to BGO, DBQ, PF and the rest of the A.A.R.S. boys who did such good work in the Midwest floods; DBQ was the clearing station for the Brooklyn Chapter of the American Red Cross; almost every paper in N.Y.C. had his photo published. IEB is out for O.R.S. JYL is out for O.O. appointment. DXO, with the aid of several of the local boys, erected a new 75-foot pole; it was a beauty for one day, came the dawn and it was gone with the wind. JFP got his Class "A" ticket. Due to flood silence, FLD got around to winding his 14- and 7-Mc. coils. JLW's Johnson "Q" blew down in the wind. HSV was appointed to a Teaching Fellowship at Washington Square College of N.Y.U. IHT is doing a lot of experimenting. DX reception is good at GDF's on 7 Mc. Off the air for two years, EIC managed to get on in time to help with some flood traffic. KBO has a new HRO and Collins transmitter on 1.75-Mc. 'phone. EAR is getting out with a pair of '52's. AOP is now living in Los Angeles. HQZ moved to Cleveland. HLL put in a quarter kw. for the DX contest. DOG is busy in his cellar making a new work bench. BSR is catching DX as usual. CHK is getting on 3.5 Mc. with new rack and panel job. BMG has HYA and IPX new net members. ELK hooked quite a few of his old gang on 3.5 Mc. IOW is using '47, '46, '10 rig. JEQ has O.R.S. prospects JFM and JFU. AHC says that N.N.W.A. will hold low-power contest. AYJ is erecting beam antenna. HWS' rig now uses 42 crystal, 6L6G buffer, pair 6L6G's final. JEB has a Comet Pro. JGC has '47-6L6 on 14 and 7 Mc. HGO can be heard on 56 Mc. JTP is on 28 Mc. with 6L6 crystal, 6L6 doubler, 6L6 doubler-final. Tu-Boro Radio Club is now affiliated with A.R.R.L. 1937 officers of Sunrise Radio Club are: pres., CJY; vice-pres., AHZ; treas., GNS; secy., DGJ. Unit 3 of Section 6, N.C.R., has meetings every Tuesday and Friday night at its headquarters in the Hempstead Post Office at 8:00 p.m.; any of the gang are welcome to attend. AZV is getting out FB with his indoor antenna. DW cleared plenty of flood traffic. KI schedules 3BWT daily. Regular operating frequencies: DQW 3511; EYS 3640; EXR 3830. BDN spends 50% of his time experimenting. The Section is still operating on 3710 kc. every night at 8 p.m.

Traffic: W2BGO 386 KI 192 PF 182 BMG 122 JBL 110 DBQ 110 (WLNB 130) DXO 59 GDF 42 DW 41 HGO 37 AZV 35 EXR 31 EIC 26 HXT-HBO 20 FF 19 JEQ 18 EYS 15 DQW 12 FLD 14 HAK 10 AA-ADW 8 CIT 7 DLR 6 US 5 CP-BKP-ENS-HJT 4 JGC-JLG-JFP 5 BDN-AHC 4 JHB-IOW 3 HWS-JTP 1 EFM 2.

NORTHERN NEW JERSEY—SCM, Charles J. Hammersen, W2FOP—HZY has made the B.P.L. every month since September. GWW has new job. BZJ bought a new mill. HQL is still going strong at Ft. Monmouth. GVZ won letter in Navy Day contest. IAP visited some hams while in Melrose, Mass. HXI has been building portable 6L6 job. APU is back in the game after an absence of five years.

(Continued on page 104)

BRUSH Headphones

● Meet every headphone requirement. They bring in weak signals strong and clear and will handle excessive volume without overloading. Response 60 to 10,000 cycles. No magnets to cause diaphragm chatter. Specially designed cases minimize breakage. Light in weight. Only 6 oz., complete with headband and cords. A quality product at a low price. Details, Data Sheet No. 10. Copies on request. Send for one.

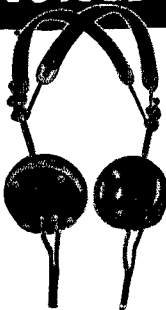

The **BRUSH** DEVELOPMENT COMPANY
1111 EAST 40 ST. CLEVELAND, O.
PIEZO ELECTRIC

MICROPHONES • MIKE STANDS • TWEETERS • HEAD PHONES • LOUD SPEAKERS

LOW PRICED! EASY TO ERECT! STEEL ANTENNA TOWER

HAMS!—Here's the ideal antenna tower—can also be used as a vertical radiator. Strong! Light weight! Extremely rigid! Comes in 20 ft. sections, with 5 ft. tip, knocked down, for building towers 25, 45, 65, 85, or 105 ft. high, as you wish. Easy to erect. Easy to climb.

50^c
FT.

t. o. b. Sioux City, Iowa

Tower Legs— $\frac{1}{2}$ " x $1\frac{1}{2}$ " x $1\frac{1}{2}$ " x 20 ft. Low carbon rail steel angle. Galvanized after fabrication.
Cross Bars— $\frac{1}{2}$ " x $\frac{3}{4}$ " x $12\frac{1}{2}$ " mild steel, spot welded to form X brace. Baked black enamel.
Bolts— $\frac{1}{2}$ " USS x $\frac{3}{4}$ "—1035 steel, cadmium plated. **Guy Wire**—300 ft. No. 9 galvanized with each 20 ft. section. Tower weighs $4\frac{1}{2}$ lbs. per foot when assembled.

Order Direct From
WINCHARGER CORPORATION
Dept. QST-4 Sioux City, Iowa

Position Vacant

Well-known transmitter parts manufacturer wants Sales and Advertising Manager. ■ Should have some experience with magazine and catalogue advertising and intimate knowledge of amateur parts distribution. ■ The man we want may now be in similar work elsewhere or a successful jobber's salesman or manufacturer's representative desiring advancement.

State experience in detail; present and expected salary; and date available. Reply to

Box J, Adv. Dept., QST, West Hartford, Conn.

RADIO ENGINEERING



RCA Institutes offer an intensive course of high standard embracing all phases of Radio. Practical training with modern equipment at New York and Chicago schools. Also specialized courses and Home Study Courses under "No obligation" plan.

Illustrated Catalog on request

RCA INSTITUTES, INC. Dept. ST-37
75 Varick St., New York 1154 Merchandise Mart, Chicago
Recognized Standard in Radio Instruction Since 1909

The Maxim Memorial Relay

(Continued from page 98)

The leading transmitting stations on telegraph (after W1AW) were W8AQ (3.5 Mc.), W8OFN (7 Mc.) and W9CWW (14 Mc.) while on 'phone W8IAI distinguished himself on 1.7 Mc., with W1SZ in the lead on 3.9 Mc., W4DLH on 14 Mc., W9GBQ on 28 Mc., and W1KH on 56 Mc. Our genial vice-president (W1KH) transmitted the message on both "five and ten" and received two score individual 56-Mc. replies which he sent in one group message through W1BHM. Messages were received from scores of League officials and members. Members in Peru (OA4N and OA4K) replied via W6AM. Word was received from K5AC via W1AW and K5AG via W1NI. It was a great relay!

—F. E. H.

Standard Frequency Transmission

Date	Schedule	Station	Date	Schedule	Station
April 2	B	W9XAN	April 30	B	W9XAN
	B	W6XX		B	W6XX
April 7	C	W9XAN	May 5	C	W9XAN
April 9	B	W9XAN	May 7	B	W9XAN
	A	W6XX		A	W6XX
April 14	BB	W9XAN	May 12	BB	W9XAN
April 16	BB	W6XX	May 14	BB	W6XX
	A	W9XAN		A	W9XAN
April 17	BX	W6XX	May 15	BX	W6XX
April 18	C	W6XX	May 16	C	W6XX
April 23	A	W6XX	May 21	A	W6XX
			May 28	B	W9XAN
				B	W6XX

Time (p.m.)	Sched. and Freq. (kc.)		Time (p.m.)	Sched. and Freq. (kc.)	
	A	B		BB	C
8:00	3500	7000	4:00	7000	14,000
8:08	3600	7100	4:08	7100	14,100
8:16	3700	7200	4:16	7200	14,200
8:24	3800	7300	4:24	7300	14,300
8:32	3900		4:32		14,400
8:40	4000				
Time (a.m.)	Sched. and Freq. (kc.)				
6:00				7000	
6:08				7100	
6:16				7200	
6:24				7300	

The time specified in the schedules is local standard time at the transmitting station. W9XAN uses Central Standard Time, and W6XX, Pacific Standard Time.

TRANSMITTING PROCEDURE

The time allotted to each transmission is 8 minutes divided as follows:

- 2 minutes—QST QST QST de (station call letters).
 - 3 minutes—Characteristic letter of station followed by call letters and statement of frequency. The characteristic letter of W9XAN is "O"; and that of W6XX is "M."
 - 1 minute—Statement of frequency in kilocycles and announcement of next frequency.
 - 2 minutes—Time allowed to change to next frequency.
- W9XAN: Elgin Observatory, Elgin National Watch Company, Elgin, Ill., Frank D. Urie in charge.
W6XX: Don Lee Broadcasting System, Los Angeles Calif., Harold Perry in charge.

Schedules for WWV

EACH Tuesday, Wednesday and Friday (except legal holidays), the National Bureau of Standards station WWV will transmit on three frequencies as follows: noon to 1:00 p.m. E.S.T., 15,000 kc.; 1:15 to 2:15 p.m., 10,000 kc.; 2:30 to 3:30 p.m., 5000 kc. On each Tuesday and Friday the emissions are continuous unmodulated waves (c.w.); and on each Wednesday they are modulated by an audio frequency. The audio frequency is in general 1000 cycles per second.

KENYONIZE TO MODERNIZE AND ECONOMIZE

Kenyon Transformer Co., Inc., is pleased to announce 38 additions to the "T" line which are designed to take care of newer tubes and circuit developments

KEN-O-TAP

The Universal Modulation Transformer

KEN-O-TAP IS THE PRACTICAL SOLUTION TO THE MODULATION PROBLEM

This new low cost universal modulation transformer may be used with any type of tube or tube combinations in transmitters. The multi-taps provide impedances to match any combination of modulator and class "C" conditions encountered in amateur transmitter applications. Will never become obsolete. Secondary designed to carry the full class "C" load.

Type T-493. Audio Level 40 watts — will modulate 80 watts. Net Price \$4.20
 Type T-494. Audio Level 75 watts — will modulate 150 watts. Net Price \$6.00
 Type T-495. Audio Level 125 watts — will modulate 250 watts. Net Price \$12.00
 Type T-496. Audio Level 300 watts — will modulate 600 watts. Net Price \$18.00

KEN-O-DRIVE

The Universal Driver Transformer

KEN-O-DRIVE IS THE MODERN ANSWER TO CRITICAL DRIVER OPERATION. Will match a 500 ohm line or any driver plate or plates to class "AB" or "B" grids.

Type T-264. Level 7 watts. Net Price..... \$4.20 Type T-263. Level 18 watts. Net Price..... \$5.40

RK39 MODULATION OUTPUT TRANSFORMER

Our Type T-462 is especially designed for RK39 beam power tubes in class "AB". The secondary winding of this transformer will carry the class "C" load and is tapped to match many of the popular 250 watt tubes.

Secondary impedances are 4,000, 6,000 and 8,000 ohms. Net Price **\$9.90**
 Secondary maximum D. C. 300, 250 and 200 MA.

For full information on these units ask your dealer for the new catalog describing our complete line of amateur and P. A. audio and power components

Chief Engineer — Amateur Section

KENYON TRANSFORMER CO., INC., 840 Barry Street, New York, N. Y.

Export Dept.: 25 Warren St., New York, N. Y.

Cable Address: SIMONTRICE — NEW YORK

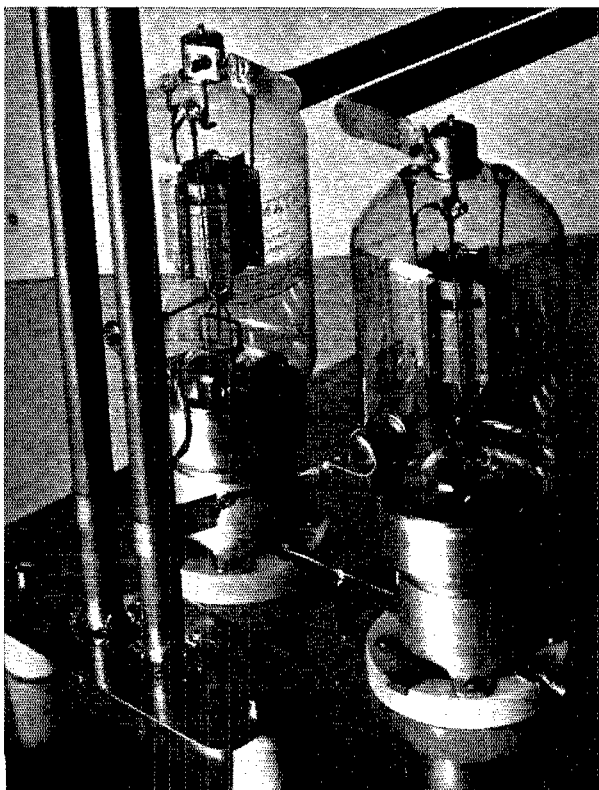

Heintz and Kaufman, Ltd.

ANNOUNCE!

THE 354-C GAMMATRON

Improved ULTRA-HIGH Frequency Operation. Same electrical characteristics as the "354" GAMMATRON — PLUS:

- Increased filament to grid insulation.
- Input capacity reduced to one-half.
- Extremely short grid lead.
- New grid and plate cap that can't come loose.

Same GAMMATRON FEATURES of superiority. Same price.. \$24.50



(Continued from page 101)

HTX has his rig at college. BPY is getting back in traffic work. HFT has new rig with 2A5. HFB's brother is getting ticket. HOZ, CMC and JUC are prospective O.R.S. BPK has '03A final. AOG is on 28 Mc. HLC moved to North Caldwell. IHK needs Asia for W.A.C. on 14 Mc. HRN is going strong with his new bug. W2FOP wishes to take this opportunity to congratulate the new N.N.J. S.C.M., W2GMN. I want to thank the members of the Section for their fine support while I was S.C.M. Without your help the N.N.J. Section could never have attained the place we hold at present in organization and traffic work. My thanks to the various R.M.'s and to P.A.M. W2GYY for their splendid cooperation. It is my earnest hope that all of you will continue your good work under our new S.C.M. GYY reports the following news: IMB is using "series modulation" again on 1.75 Mc. IBZ has suppressor grid-modulated 59 on 1.75 Mc. as "stand by" transmitter. KFH (ex-IGL) has difficulties from his 28-Mc. 'phone. GZG, GYY, JAB and 3FBG are thinking of forming "The Kilowatt Club"—they each use 1 kw., 2400-volt transformers as plate supplies! DJB is working DX by the bushel on 14-Mc. 'phone and c.w. IHD is back on 1.75-Mc. 'phone after a long time on 7 Mc. GON is putting '10 on 14-Mc. 'phone. HZR and EKU celebrated O.O. and O.P.S. appointments by running bootlegger signing "W6ERT" on 56-Mc. 'phone to earth in Newark area. AHN sounded "assembly" for his A.A.R.S. 'Phone Net during the flood period and was much pleased to note the turn-out. Even the Reserve Stations appeared on the net's frequencies each night for a week.

Traffic: W2HZY 899 BCX 519 (WLNF 555) GGE 233 CGW 145 BZJ 112 HQL 92 GVZ 79 HOZ 68 IAP 65 CGG 62 FOP 39 GMN 36 CMC 32 HBQ 19 HXI-APU 18 ECO-IQM 14 ICJ 9 IZV 16 CIZ 11 HTX-CJX 6 BPY 5 EKU 4 HFT-BFB 2.

ATLANTIC DIVISION

EASTERN PENNSYLVANIA—SCM, James M. Brun- ing, W3EZ—P.A.M.: 3EOZ, R.M.'s: 3AKB, 3AQN, 3EOP, 8ASW, 3GDI handled a nice amount of flood traffic. 3GHP has been installing 'phone. 3CGM is all set to come back on the air with high-power 'phone. 3BRO is another prodigal son returning to the air via 14-Mc. 'phone. 3AQN is now employed by the Certain-teed Products Co. in their electrical department. 8PCL has been working on 56- and 1.75-Mc. 'phone with assistance of 8EBF. 8FLA recommends 8OML and 3FXZ for O.R.S. 3CHH handles a little traffic in addition to DX. 3EJW worked a G6 on 3.5 Mc. 3EOP says the flood cut down a lot of his traffic, but still he managed to make the B.P.L. SEU attended a refrigeration school at Indianapolis. 3BBV has his equipment working fine at new QTH. 3CZS is enjoying a new RME69. 3CEQ is to be married on Easter Monday. 3FBJ has been operating 1.9-Mc. 'phone with very good results. 3EDC gets considerable enjoyment thru traffic work. 3AGK has been making some improvements in his station. 3QP relayed 8 flood messages while sick in bed; Jack is now running a full k.w. to a pair of color-less '50T's. 3GMK went from 3.5 to 7 Mc. and couldn't work anything; he lowered the south end of his 7-Mc. zepp about three feet and now works almost anything on the air. 3ADE reports quite a number of Harrisburg hams now active on 28 Mc. 3ETA worked a few Z's on 'phone. 3EUP has everything working OK now on 14 and 7 Mc. 3BRZ has been working his usual DX range; "Denny" is now erecting a 14-Mc. "Vee" antenna. 3BGD worked Roumania and Yugoslavia on 'phone for nearly an hour. 8OML is still working on B.C.L. trouble. 3FXZ runs 400 watts on 7 Mc. and receives regular 88 to 89 reports from her K6NXD schedule; "Mary" will be glad to QSP traffic to Hawaii for any of the gang needing a quick route. 3BES was visited by 6CUH. Stations reporting as "active": 3DXC, 3EZ, 3FIG, 3GJY, 3GLQ, 8ASW, 8EKG, 8HKS and 8NNC. The Electric City Radio Club of Scranton will hold its first Annual Hamfest in May; dandy prizes are being provided. The York Road Radio Club was host to visiting clubs and, as usual, provided an enjoyable and instructive evening; 6CUH was the main speaker and gave a most interesting talk. The Beacon Radio Amateurs Club in Phila. is progressing nicely. 8MZF rebuilt. 8BEV, 8NMA and 8MZC are on 28-Mc. 'phone. Shamokin Radio Club. 8MRH, bought new receiver and invites all hams to meetings held every Wednesday evening.

Traffic: W3EOP 568 (WLQB 122) QP 446 AKB 217 BES 149 FXZ 120 GJY 84 EWI 77 GDI 66 AQN 55 ETM 40 (WLQF 14) EDC 27 ADE 22 EZ 21 AGK 17 GLQ 14 FBJ 12 GMK-GHP 8 BGD 7 CHH 5 DXC-FIG 4 CZS 2 BRO-

FGN 1. W8EKG 88 FLA 72 (WLQC 47) NNC 31 HKS 24 OML 14 PCL 9 ASW 4.

MARYLAND-DELAWARE-DISTRICT OF COLUM- BLA—SCM, Edgar L. Hudson, W3BAK—3FDJ, secretary of the "Mike and Key" Club of Baltimore, sends the following notes: The "Mike and Key" Club will hold its Spring Hamfest on April 10th at the Hotel Emerson in Baltimore; price \$2.50, with a Maryland chicken dinner and plenty of it; Super Skyrider and probably an NC100 receiver for first prizes, besides many others. GRT, one of Baltimore's newest stations, is working 1.75-Mc. 'phone. The 56-Mc. gang is constantly growing, and Washington and Wilmington are being worked quite consistently. HG and HI are using superhets for receivers and a number of the stations are crystal controlled—WA, AUC, FDJ, HI and several others. DWC is becoming famous as the only super hi-fidelity station west of the Fallaway. GR has been changing QTH so much that the F.C.C. had to put on an extra girl to handle his license changes. FAM is W.A.C. on 14-Mc. 'phone, and needs only Arizona for W.A.S. on 1.75-Mc. 'phone. FTD has left 1.75 Mc. to go on 56 Mc. EPR has given up his '03A for a T55. EVK jacked up his power to about 300 watts on 3.9 and 1.75 Mc. Following from the Washington Radio Club, via 3EZN: ADQ is experimenting on 112 Mc. and reports S9 signals across the city, using 6A6, 2DXX, Cary Sweeney, N.B.C. engineer, gave a mighty interesting talk to the club on a recent visit. 3EHE is changing QTH to Phila. A committee from the Washn. Radio Club met with representatives of: F.C.C., Army, Navy, Western Union, Postal Telegraph, Red Cross, American Tel. and Telegraph. The main topic of discussion was to coordinate amateur and emergency communications with Army and Navy emergency communications and the general activities of the Red Cross. They met twice; the summary of the meetings was condensed in a short letter to President Roosevelt. ELN handled flood messages. FII blew plate transformer. A. L. Bud-long addressed the club. SN is building new rig with 150T final. BWT handled some flood traffic; was key station for "G.P.R." BKZ won handsome globe for shack in A.A.R.S. 3rd C.A. Speed Contest; Red Cross traffic was handled during flood. CIZ measured 9642 miles on trip to West Coast. GFF handled one flood message, and is trying for W.A.S. CAB handled some emergency traffic. FSP received four messages in "G.P.R." CQS' traffic was all flood traffic. PNG handled flood traffic. CDG is having trouble with rig on 14 Mc. FIU is experimenting with beam antennae. CDQ took first "G.P.R." message, then promptly took tonsillitis! BAK handled "G.P.R." message from Delaware. GAD has new 266-ft. antenna. Following Wilmington, Del., stations are active on 56 Mc.: BTQ, FFF, EGN, HC, DQZ, DUK, CGV, FNI, AIS, DTK, EPP, DRD, FGD is hearing lots of European DX on 3.5 Mc. Reports received from the following: DML, EHW, CWE, who reports from Michigan College. EYX, former 2CYA, is scheduling 2JFP so he can get all the gossip from where he went to School at Stony Brook, L. I.; he handled several emergency messages during the flood. 3DQN/WLMC has been sick with flu; he kept consistent schedules with flood area, and handled lots of emergency traffic thru DQN/WLMC as well as CXL/WLM.

Traffic: W3CXL 279 (WLM 2722) SN 531 BWT 525 DQN 15 (WLMC 176) BKZ 137 CIZ 54 EZN 34 FPQ 47 GFF 13 CAB 20 FFF 19 FSP-CQS 17 GKZ 16 FNG 9 FQB 7 CDG 6 FIU 5 CDQ 1 BAK 1 GAD 14.

SOUTHERN NEW JERSEY—SCM, Carroll D. Kent- ner, W3ZX—The South Jersey Radio Ass'n officers for 1937: BEI, pres.; KW, v.-pres.; BWR, secy.; J. Burch, treas. The club celebrates the 20th anniversary of its founding this year. A recent notable action was to incorporate the club under the laws of the State of New Jersey. GRM is a new reporter—he received his ticket on Christmas eve. GMY of Vineland and FTX of Millville are traffic-minded and are out for O.R.S. tickets. GPR, using 15 watts, reports flea power QSO with BNSE who was using 6 watts. DQO is busy organizing new N.C.R. Net in Millville. DNU QSO'd HB9AD and F8IIB on 3.5 Mc., and has 45 states toward W.A.S. on 3.5. BIR has 801's now in place of '10, and reports the Trenton Radio Society doing much to suppress boot- legging and B.C.L. interference. ZI put the New Jersey "G.P.R." message direct into Washington, and assisted in the QSP of the Alaskan "G.P.R." FTX again tops the Section with a grand total, 50 of which were flood messages. BEI was on duty during the whole emergency, doing in- telligent listening and handling 35 emergency messages. FMR, of Zarephath, has recently moved to this Section from Washington, D. C. The Greater Camden Amateur

Radio Ass'n elected following officers for 1937: AYZ, pres.; DAJ, v.-pres.; BYK, treas.; EHU, cor. secy.; DJR sgt.-at-arms.

Traffic: W3FTX 2 AEJ 8 BO 22 VE 105 EFM 62 DQO 5 DNU 74 EEQ-BIR 4 ZI 138 FTK 1883 BEL 49 QL 15 FBM 32 ZX 22 BYR 67.

WESTERN NEW YORK—SCM, Charles F. Smith, W8DS—C.R.M.'s: W8JTT. R.M.'s: BJO, AQE, CSE: L.O. Two of the boys make the B.P.L. and our new YL O.R.S., KYR, sends in the third largest report. JTT again leads followed closely by JQE, who is becoming one of the most consistent traffic handlers in our Section. KYR did a very creditable job at the Buffalo Scoutorama Radio booth. CSE is still hopping from one frequency to another keeping his many schedules perking. BJO had some more tough luck with his "skywire" during the recent ice storm. PLA reports his T55 has gone with the wind. FCG is busy with A.A.R.S. and O.R.S. activities. AQE carries some nice schedules. GWY is doing good work as "O.O." and also reports into the W.N.Y. Net daily. FUG is still handling most of the traffic in and out of Rochester. NWZ and JMI are reporting regularly into the net. GWT reports AVF the official rack-builder for the Penn Yan gang. EBR is back on the air with 250 watts, an FB7 receiver, a new antenna and a nice traffic total. DHU reports Ex-2ETF is now 8QIO in Elizabethtown and 8EIJ active in Ticonderoga. OXI is looking for reliable schedules west and south. OCH is in Florida for the winter. LUQ is the only O.P.S. to report this month! AOR needs Africa and S.A. for W.A.C. QGL makes first report; he is building 50-watt job and reports FHO working nice DX on 7 Mc. MQX is now on with 300 watts and expects to lead the Section in traffic. PBO is on 14, JHI on 28 and OES on 3.5 Mc. HHL likes his new "Sky-Chief." IBU, KDL, OMJ and MBW have been recommended for O.P.S. KJW is attending school at Troy, N. Y. OAG has moved to New Jersey for a short time. QGS, AXW and BFG are working DX on 28 and 14 Mc. CYT has new 101-X receiver. BHK and DHQ are building a real portable job for emergency work. The two W.N.Y. traffic nets are still operating FB and adding new members continually. If you are interested, write the S.C.M. or any of the W.N.Y. Route Managers listed at the top of this column. 73.

Traffic: W8JTT 517 JQE 57 KYR 270 CSE 167 BJO 162 PLA 129 DSS 103 FCG 66 AQE 65 FUG 64 GWY 62 NWZ 44 JMI 41 GWT-EBR 35 PCW 33 DGL 26 OXI 22 KXA 20 HTT 16 QHX 12 LUQ 7 AOR 5 QHU 3. (Nov.-Dec., W8FUG 51).

WESTERN PENNSYLVANIA—SCM, Kendall Speer, Jr., W8OFO—R.M.'s: 8KWA, 8KUN, 8MOT. Reports indicate splendid work done in the Ohio Valley flood by the following Western Penna. amateurs: BBV, GJM, GUB, FIP, INE, JZN, KUN, KWA, OFO, PX and QAN. Traffic reports and news items for this column are invited from all amateurs in West Penna. whether you are O.R.S./O.P.S. or not. Write to the S.C.M. at Lowber, Pa. New R.M.'s: 8KUN. Prospective O.R.S.: JSU. Prospective O.P.S.: OIZ. B.P.L.'s this month: KUN and MOT. KUN is high man. PX has nice traffic total with his flood work. NDE says KUN is now a member of the Haywire Net. UK and CUG demonstrated how the W. Pa. O.R.S. Net operates at the recent A.T.A. meeting in Pittsburgh. YA has 3NF back taking post-grad and operating the station; George has been at the U. of Mich. but will be at Penn State until June at least. GJM says OUT moved his 28-Mc. rig to his dental office. FIP has formed an amateur radio club at the Penna. Association for the Blind and is now building a transmitter there. IOH says conditions on 3.5 Mc. are FB. DDC is rebuilding. LGD says LBS gave a talk on amateur radio at the West Newton Kiwanis and relayed a message from the club rooms for the P.I. IYQ is out of the hospital after a major operation. KNB is back on the air. OIZ rebuilt using '47-'46-'841-pair 830's Class B modulated on 14-, 3.9- and 1.75-Mc. 'phone. MIW announces a Jr. op. Congrats, Zip. FCO is back on 1.75-Mc. 'phone. OVT now has a Class A ticket. FXK is on 56 Mc. AWW is building e.c. BVP is on 28-Mc. 'phone. New hams: Charleroi, QOD; Belle Vernon, QNW. The Valley Key and Mike Club at Sharon held its first anniversary party with a nice turnout; they were given a swell write-up with photos in the local newspaper. JSY arrived at Miami, Fla., with his radio-equipped trailer; he writes that he is working for Eastern Airlines there and will go in as radio operator as soon as he gets his commercial ticket. 80YK reports very interesting and instructive speakers at meetings of the Emporium (Pa.) Section, Institute of Radio Engineers. Recent speakers have included H. H. Beverage,

R.C.A. Communications, and Prof. F. E. Terman, Leland Stanford University. Anyone interested in being put on the mailing list to receive notices of these I.R.E. meetings should write R. N. Palmer, W8OYK, Secy-Treas., of the Emporium Section, 36 West Fourth St., Emporium, Pa.

Traffic: W8KUN 749 MOT 518 KWA 213 PX 210 NDE 166 OFO 149 CKO 88 UK 85 QAN 64 KOB 61 YA 47 (WLMA 139) ADY 42 GJM 34 CMP 33 CUG 26 AXD 18 FIP 15 IOH 11 MWV 10 DDC 8 DGL-LGD 7 RG 5 EBJ-IYQ 1 JSU 343.

ROANOKE DIVISION

NORTH CAROLINA—SCM, H. S. Carter, W4OG—Raleigh: DW leads the State in traffic total. EG worked his 80th country; he is buying modulation equipment. Greensboro: MR has new lattice work tower up; he worked his 84th country. Wilmington: FT is doing very good work on 28 Mc. BQZ is building a low-powered rig for portable use in case of emergency. EEL is experimenting with an RK-20. BRK is handling traffic on N.C.R. CPT has a new receiver. Winston-Salem: 4NC had as visitors during the month, A. L. Budlong, from A.R.R.L. HQ's, 2HVN from New York City, 8AIE, Syracuse, N. Y., and 1KKR, Providence, R. I. DWB had a good score in the O.R.S. Party. DCQ came home from school long enough to work the O.P.S. Party. ABT has a new NC100X receiver. CFR is on again in his new location, as well as OG, who has moved after being in one place for 12 years. With the 'phones: DIS blew a 211 in his final. DSY is running a kw. on 14 Mc.; he keeps a daily schedule with South Africa. BFB has a new power transformer. BFX is back on the air working 3.5-Mc. c.w. and 3.9-Mc. 'phone. ALD has his rig working FB. QI is working DX on 14 Mc. DKF is erecting a 75-foot pole for 1.75-Mc. antenna.

Traffic: W4DW 166 ABT 42 DWB 14 CJN 12 ECK 11 BRT 10 CX-CYY-BHR-NC 4 OG 3 BVD 2 DCQ-DGU 1.

VIRGINIA—SCM, Charles M. Waff, Jr., W3UVA—FKD is on 14-Mc. 'phone and expects to QRO soon; he needs Nevada for W.A.S. (so do a lot of us!). DBI has new 66-foot tower. RL is now on 28-Mc. 'phone and c.w. UVA has a new HRO receiver. EXW has worked 59 countries. GJP is new member of Rag Chewers Club. AVR has new RME-69 receiver. GJP has gone to Seattle, Wash., for some time. GBC is working some DX these days with a '10 final. EMA has a new HRO receiver. BFW is on week-ends, but expects to move his shack to Richmond soon so he can be on more. BGS pounds brass for a railroad all day. FKD is a new O.P.S. AIJ has a new Sky Rider receiver and likes it FB. GPC is a member of the Rag Chewers Club. FFD works W6's on 3.5 Mc. with his '10. CGB is on 4-Mc. 'phone. BIW has two new Johnson Q antennas. CHE is new O.P.S. The VIRGINIA FLOATING RADIO CLUB will meet in Roanoke on Sunday, April 18th. Plan now to attend this first meeting of 1937. Write W3CA for information.

Traffic: W8GJP 5 RL 4 FKD 3.

Briefs

1.75-Mc. 'Phone

W5FPO, station of the Short Wave Amateur Club of America at New Orleans, La., has been stepping out in fine shape on "160 meter" 'phone. Some of the stations worked during December and January: W1BWN JHW W2AST LX JWX JZR IWQ HWZ W3FGE AFH FAM FPK GCQ GFI W6KOH NLS FMO NCR MFS KOA W7FLO ENX VE5OT VESAIHV MZ AHD K6NJV K4EBX. . . . W4, W5, W8 and W9 contacts are too numerous to mention. Heard cards have been received from Germany and Ireland. George F. Norton, W4EEE, Athens, Ga., has received his W.A.S. certificate on the strength of contacts with all states on "160 'phone"—he is the first to qualify for W.A.S. with "160 'phone" exclusively. Who will be next?

W3GRM took a message from W2JBG addressed to W3FVC, Philadelphia. He called "CQ Phila" and raised—guess who . . . none other than W3FVC! Total elapsed time from taking message until sending it direct to W3FVC was 15 minutes. Snappy work.

A 7-Mc. club is being organized in California to be known as the "Sunshine Club." Meetings will be held Sunday afternoons. The only requirement is receiving and sending ability of 15 w.p.m. or higher. Crystals will be available to members of the club at a very nominal cost. For further details communicate with W6LHW, 5336 Stratford Road, Los Angeles, or W6KNO, Clearlake Highlands, Calif.

Makes Sending EASY Cuts Effort in Half

Insist on The Genuine Martin VIBROPLEX SEMI-AUTOMATIC KEY

Simply press lever—
machine does the rest

**JUNIOR
ONLY
\$12.50**

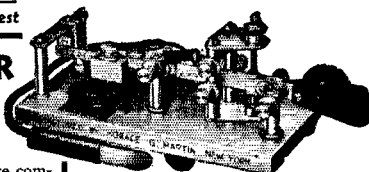

Smaller and more compact. Large contact points. Black japanned base. A low priced key with world famous Vibroplex quality.

Vibroplex's speed, clarity of signal and ease of operation assures the user the fastest, best and easiest way to send. Experienced operators everywhere know this—that's why over 100,000 use only the Vibroplex. Easy to learn.

Easy to use. Easy to own. Liberal allowance on old Vibroplex. So if you want the best, insist on the Genuine Martin Vibroplex key. Accept no substitute. Place order TO-DAY! Money order or registered mail. Other models \$17.00 and \$19.00.

FREE

Illustrated
Catalog
Write for It!



THE VIBROPLEX CO. Inc.

832 Broadway

New York, N. Y.

LEARN CODE RIGHT

Tapes for Every Need—Even Airways
— Send You Typical Messages by
Instructograph.

It's easy and practical to learn or improve your Radio or Morse code. With an INSTRUCTOGRAPH you may practice at your convenience at any speed. Buy or Rent, at low cost. Send for full information to-day to—

Instructograph Co., Dept. Q-4
912 Lakeside Place Chicago, Illinois
Representative for Canada
Radio College of Canada
853 Bay St., Toronto

WE ALSO HANDLE: HALLICRAFTER SHORT WAVE RECEIVERS — MICROPHONES — VIBROPLEXES — TAYLOR TUBES . . . CASH OR TERMS



Mims SIGNAL SQUIRTERS

ROTARY BEAM ANTENNAS

20 and 10 METERS ONLY

Full descriptive information and details of our kits making it easy for you to "PUT YOUR SIGNAL WHERE YOU WANT IT—WHEN YOU WANT IT THERE." Send 5c for your copy.

Mims Radio Co.

[M. P. Mims, W5BDB]

P. O. Box 504

Texarkana, Ark.

LEARN RADIO

New Classes Now
Forming! Send for 48-
page catalog, explains

fully. 500 licensed graduates placed in past 6 years in broadcasting, shipping, police radio, aviation, etc. We teach all branches. Oldest, largest and best equipped school in New England. Equipped with Western Electric sound and broadcasting equipment and RCA marine transmitter. Course prepares for all United States Government telegraph or telephone licenses.

MASS. RADIO SCHOOL, 18 Boylston Street, BOSTON

Correspondence

(Continued from page 70)

with this traffic business. Yes, and I'll go better than that and say that this little tale I am going to relate will be of benefit to any one who keeps appointments of any kind, and that would include us all, ham or not.

Now, to start with, I keep a schedule every morning with W4PL and W3CIZ, a three-way arrangement for the purpose of handling traffic. This is at 5:30 A.M. E.S.T., or 4:30 W4PL's time. It so happened this morning that I had a slew of messages for W4PL and W3CIZ had a lot for me. Well, I managed to clear W3CIZ with only enough time left to arrange a sked this evening with W4PL to move my traffic.

A few minutes ago my 'phone rang here at the office and I was informed that a party was calling me long distance from Cambridge, Ohio, fifty miles away. I soon found that W8VP was on the other end with the information that he had W4PL QRX and W4PL wanted me to know that he was unable to keep the sked with me that night but would be on a half hour earlier the next morning and would that be all right with me. . . .

Most of us, if we found that we would be unable to keep a schedule would just simply forget about the sked and then explain later. But not of "Pop". He sits down and gets contact with a station as close to me as possible and then gets a 'phone call through to me with the advice that he can't be on. . . .

That 'phone call is going to stick in my head for a long time and it's going to do me a lot of good. And I think maybe there are others of us whom it might help if you'd put a little item in QST. When one stops and reflects a bit he realizes the importance of being dependable, and then he sees that dependable stations who are always on the dot when expected make the backbone of the A.R.R.L. traffic system, and a weak vertebrae in a thing like a backbone is not so simple. That's a thought for the Trunk Liners.

From now on I'm going to be awful touchy about breaking skeds.

—Chas. N. Moore, W8HMF

Delta Air Lines, Candler Field, Hapeville, Ga.

Editor, QST:

I am writing you with the hope that you will find room in QST to caution the 160-meter amateurs to check up very carefully on third harmonic emission, especially those near the high-frequency end of this band. For the past two or three weeks, we have had very serious interference from amateur 'phone stations operating in this band, and have had to telegraph two of them because of this QR.M.

At this time of the year, radio conditions are very tricky, as you well know, and harmonic emission that would not be heard during other times of the year, gets out with amazing strength. Our day operating frequency is 5707.5 kc., and several times during the day, for the past week or two, our entire radio system between Atlanta and Dallas has been completely blanketed by two W5—stations and very serious interference from two other stations experienced.

When we have such conditions as the above, the safety of life and property is greatly endangered, especially so during adverse weather conditions. This is not for the purpose of criticizing the amateurs, but is to caution them to check up on harmonic emission, and take steps to prevent it. The Handbook is full of ways and means of doing this.

I am an active amateur myself, and have been for the past 16 years.

—J. W. Spralrin, W4KV, WLR

A Survey of Crystal Oscillator Tubes

(Continued from page 38)

always should be operated with cathode-resistor bias in addition to grid-leak bias.

7. There is an optimum value of cathode inductance for each tube in the Tri-tet circuit, and this value should be used.

8. Beam-type tubes are not especially capable of greater output than the pentode-type tubes in crystal oscillator circuits if they are operated within safe ratings. Approximately 15-watt fundamental output is safely obtainable with any of the tubes in the group tested.

DON'T SHORT CHANGE YOUR POWER SUPPLY

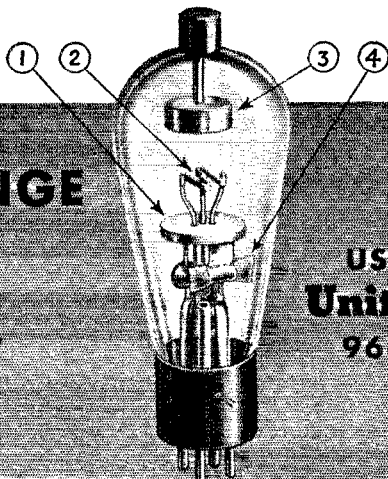

USE
United
966

1. Large Svea metal baffle to deflect heat from bottom of bulb keeping condensed mercury temperature in proper relation to ambient temperature.
2. Ideal tube temperature conditions and radiation protect filament life.
3. Deep cup anode of processed Svea metal, free from occluded gases.
4. Measured mercury pellet controls mercury volume. ABSENCE OF EXCESS MERCURY PREVENTS AMALGAMATION ON ELEMENTS AND GETTER. RESULTS: CLEAR BULB FOR RADIATION, LESS HEATING TIME DELAY.
5. All UNITED 966 rectifiers are pre-shipment tested at 3200 volts DC to assure that they are *Built to Take It*.

\$1.75

UNITED ELECTRONICS COMPANY — 42 SPRING ST., NEWARK, N. J.

Futuristic

Type HFM

Mobile Crystal Control

for 5- and 10-Meter

PHONE — CW — ICW

and 20-40 Meter CW

- Single 40 meter crystal for all bands
- 10 Watts Carrier on 5 and 10 Meters
15 watts on 20 and 40 meters
- Micalex insulated plug-in coils

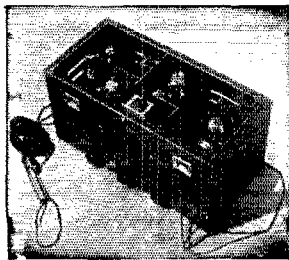
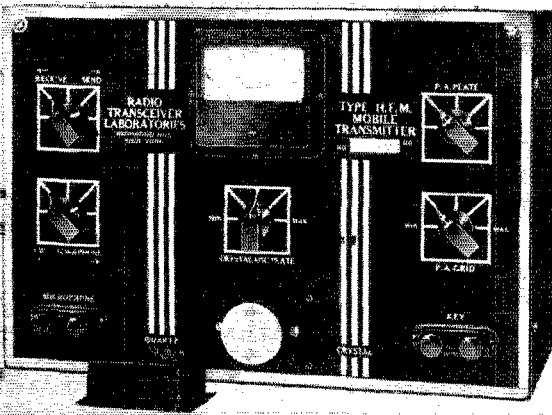

TYPE TR-6A6
DUPEX
TRANSMITTER
RECEIVER

\$39.75

SPECIAL EQUIP-
MENT for ALL RE-
QUIREMENTS.
Bulletin 37 will in-
terest you. Write
for it—it's FREE.

Type HFM CRYSTAL CONTROLLED MOBILE or FIXED
TRANSMITTER. Complete with all coils \$48 net F.O.B.

Bliley LD2 Mounted Xtal \$4.80 extra

RADIO TRANSCEIVER LABORATORIES

8627 115th Street, Richmond Hill, N. Y.

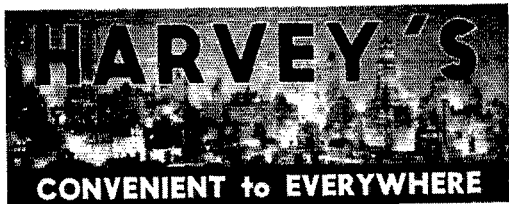

Due to popular demand Harvey Radio Co. is again offering the

89-807 TRANSMITTER

This transmitter is completely described in December 1936 QST page 28. This kit is complete in every detail, all that is needed is a soldering iron and elbow grease. Parts include RCA tubes, Bliley xtal, Bud dried and punched chassis, Cornell-Dubilier condensers, **\$18.95** and Coto coil. Complete at the sensationally low price of **\$7.95**. Power supply for the above rig is composed of UTC and Cornell-Dubilier parts and costs

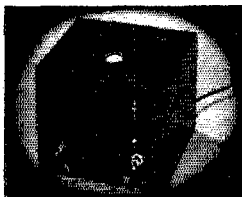

BLILEY UNMOUNTED CRYSTALS

80 and 160 meters..... \$1.50
Large selection of new and used WESTON Meters at bargain prices.
New JOHNSON "Q" with improved straight tubing IN STOCK.

SPECIAL POWER SUPPLIES
500 Volts to 400 Volts —
225 MA — D.C. \$8.49
600 Volts — 200 Ma. D.C. 8.75
Highest quality parts; UTC — Cornell-Dubilier — RCA — Bud ... Completely mounted but unwired.

HARVEY TRANSFORMERS
TYPE I. 750/1000 V.A.C. — Each Side — 300 Ma. \$5.79
TYPE II. 1000/1250/1500 V.A.C. — 300 Ma. 7.39
TYPE III. 1500/2000/2500 V.A.C. — 300 Ma. 11.98
TYPE IV. 1000/1250/1500 V.A.C. — 500 Ma. 11.79
TYPE V. 600 V — Each side — 200 Ma. 2.98
TYPE VI. 500/425 V.A.C. 225 Ma. 2.98

NEW UTC PA 913 OSCILLOSCOPE

A really stable oscilloscope. Complete kit using new UTC transformer and Cornell-Dubilier condensers, IRC resistors, in black crackle can. Price, less tubes. **\$11.95**

NEW RK 20A

Heavy duty RK20..... **\$17.50**

BLILEY RUBBER XTAL
VF 1..... **\$8.00**

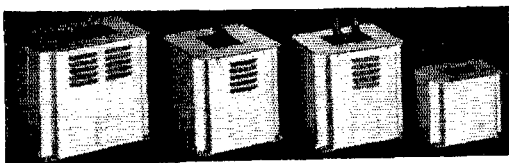

NEW HARVEY CHOKES

20 hy 200 ma. Smoothing
5-25 hy 200 ma. Swinging. **\$1.70**
20 hy 300 ma. Smoothing
5-25 hy 300 ma. Swinging. **\$3.20**
20 hy 400 ma. Smoothing
5-25 hy 400 ma. Swinging. **\$3.98**

20 hy 550 ma. Smoothing
5-25 hy 550 ma. Swinging. **\$5.59**
Cased, can be mounted in any position. Ceramic insulators, high voltage insulation. Guaranteed 3 months.

The *Value* of the Month

HARVEY TWIN 20 KIT

100 watts input on high frequencies . . . Less than 30¢ per watt . . . Uses pair of new Taylor T 20 in P.P. with highest quality components. Complete kit with tubes, drilled and punched crackle chassis, Cardwell condensers, Coto coils, etc.

RF KIT..... **\$19.95** POWER SUPPLY.. **\$9.95**

OUR *Best* VALUE IS OUR RECORD OF LOYAL SERVICE

HARVEY

Radio Company of New York

103 WEST 43rd STREET • NEW YORK, N. Y.

CABLE ADDRESS: HARADIO

9. A medium-C plate tank circuit is preferable for 3.5-Mc. fundamental Tri-tet operation (C_p , 100- μ fd. or more). The same coil can then be tuned to the second harmonic for Tri-tet doubling.

10. The grid and plate circuits should be isolated from each other, and glass tubes should have an external shield to avoid stray feedback coupling and erratic operation.

"In the Public Interest, Convenience and Necessity"

(Continued from page 86)

W8OHG, W8ICM, W8KMZ), W8PFJ, W8RR, W9AKT, W9BNT, W9DOP, W9JLM.

POST-MORTEM AUTOPSY

Sober reflection on the amateur emergency work during the Ohio River Valley flood, viewed from the organizational standpoint, shows that work to have had three noteworthy characteristics.

First is an obvious indication of progress in preparedness and technique. This is, paradoxically, proved by the fact that a few "glaring" errors have been pointed out in specific cases, by the feeling that these errors were disastrous, alarming. Analyzed, this attitude means that, in previous large-scale emergency work, there has been so much imperfection, so little occurring according to definite plan, that individual errors blended readily into the maze of the whole. This time it was different. Despite the confusion resulting from so many different services operating simultaneously, from the amateur standpoint there was preparedness, planning; there was organization—organization of the type that makes accidents the exception, rather than the rule. In consequence, such mistakes as did occur stood out in bold relief. The general quality of the amateur work was on such a high plane that errors and fumbings—although fewer in both numbers and percentages than ever before—jutted sharply above the common level of splendid performance.

Second is the spectacularly effective work of the 'phone stations. Even the most seasoned partisan is, in this instance, if he is honest with himself, constrained to admit that amateur radiotelephony during the January-February flood proved a worth so indisputable that it can never again be successfully questioned. In the first place, the number of 'phone stations active was tremendous. Yet so well was the work organized that after January 26th they operated in limited territory with practically no serious mutual interference. Incredible quantities of traffic were pushed through in rapid-fire fashion, with a surprising degree of accuracy. For certain types of emergency traffic-handling, especially that not involving record communication, it was clearly demonstrated that 'phone has no peer. One noteworthy facet of this situation is the fact that a given stretch of territory can be monitored ten times more rapidly and easily when listening to 'phone than with c.w.

Third is the almost complete absence of personal traffic. In past emergencies the bulk of ama-

NEWS! NEW SIX BAND TRANSMITTER—RANGE 1500-60,000Kc.

A real transmitter for portable or mobile use. The new UHX-10 uses crystal control for 10-20-40-80-160 operation and EC on 5 meters. Real DX worked on first 10 meter fone test. Switch for phone — MCW-CW. Dimensions 12" wide, 8" high, 6" deep. Net price only \$62.00.

A.C. Power supply delivering 300 v. @ 150 Ma. Net \$26.00

NEW RCA ACT-20 — Immediate delivery — Down payment. \$14.50
SPECIAL TERMS ON THE NEW TEMCO TRANSMITTERS

OUR NEW PAYMENT PLAN MAKES IT EASY FOR YOU TO OWN ONE OF THE LATEST RECEIVERS OR TRANSMITTERS. BE WISE — COMPARE OUR TERMS WITH OTHERS.

DOWN PAYMENT AND MONTHLY PAYMENTS AS FOLLOWS:—

NC-101X	\$14.75	New ACR-155	\$ 8.25
NC-100	13.75	RCA 151 Oscilloscope	5.50
NC-100X	16.25	Ottawa OR-5	11.00
HRO	19.75	Harvey 60X	7.75
New Super Pro	26.75	Harvey 80T	15.50
RME 69	14.75	Harvey UHX-10	7.00
Breting 14	11.50	Harvey 700R	61.60
Super Skyrider	10.25	Pair of 250 TH or TL	10.50
Skyrider Challenger	7.75	Pair of 806	10.50
ACR-175	13.15	Pair of Taylor T-200s	9.25
Patterson PR-15	12.50		

(ABOVE PRICES ARE ON 10 PAYMENT PLAN)

(TUBES AND PARTS ON 5 PAYMENT PLAN)

OUR PRICES ON 1937 HOME RADIOS AND AUTO RADIOS WILL INTEREST YOU.

DELAWARE RADIO SALES COMPANY

WILLARD S. WILSON—W3DQ

405 DELAWARE AVENUE

ESTABLISHED 1920

WILMINGTON, DELAWARE

DIVIDENDS

from your "Junk-Box"

by applying the money-saving ideas in

HINTS & KINKS

(VOLUME TWO)

For the—

WORKSHOP

KEYING SYSTEMS

POWER SUPPLY

RECEIVER

FREQ. METERS &

ANTENNA SYSTEMS

TRANSMITTER

MEASUREMENTS

ULTRA-HIGH FREQ.

PHONE WORK

128 pages of dope — GOOD DOPE

Price 50¢ postpaid from A.R.R.L., West Hartford, Connecticut

PRECISION CRYSTALS

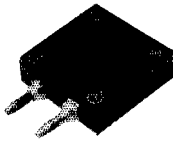

Crystal Holder

Highest quality crystals one-inch square, carefully ground for frequency stability and maximum output. Be sure of your transmitter frequency — use PRECISION CRYSTALS.

'X' cut PRECISION Crystals carefully ground for maximum power supplied within 0.1% of your specified frequency and calibrated to within 0.03% are priced as follows: 1750, 3500 and 7000 kc. bands —

\$3.00 each. Add \$1.00 to above price if plug-in, dustproof holder is desired. (Holder as illustrated to fit G.R. jacks or round holder to plug into a tube socket can be furnished.) G.R. jacks to plug illustrated holder into — \$1.15 pair.

Low frequency drift crystals (Type LTC) having a drift of less than 5 cycles per million per degree C. are supplied at the following prices: 1750 and 3500 kc. bands — \$3.50 each; 7000 kc. band — \$4.00 each. Holder \$1.00.

'AT' cut crystals for commercial use quoted on at your request. When ordering our product you are assured of the finest obtainable. Now in our seventh year of business.

PRECISION PIEZO SERVICE

427 Asia Street Baton Rouge, La.

UNIVERSAL PORTABLE Recording Machine

A precision machined compact outfit that positively eliminates all waver — Records in either direction at 33 $\frac{1}{3}$ or 78 r.p.m. — 90, 110 or 130 lines per inch — 110 volt AC 100% synchronous motor — Solid 16 inch turntable — Constant speed rim belt drive — Also stationary machines, amplifiers, cutting heads, special acetate pickup, etc.

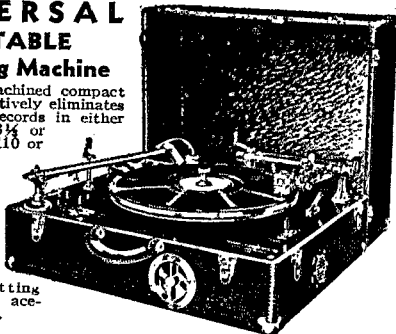

UNIVERSAL MICROPHONE CO., LTD.

424 Warren Lane Inglewood, California.

Epco STORAGE BATTERY ELIMINATOR

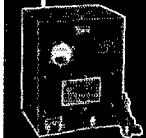

Supplies filtered D.C. suitable for operating auto radios, public address systems. Voltage adjustable from 4 $\frac{1}{2}$ to 9 volts at 10 amps. Write for detailed information.

\$19.75 As Illustrated Variable Voltage \$15.75 Model B 6 volts—5 amps. Fixed Voltage

ELECTROPAK

Supplies rectified D.C. for operating relays, solenoids and remote controls. Voltage ranges from 6 to 24 volts, rated at 2 to 15 amps. Operates on 110 volt A.C.

ADAPTOPAK

Operates A.C. radios in D.C. districts and 110 volt A.C. radios in autos and trailers.

ELECTRICAL PRODUCTS CO. 6539 RUSSELL ST. DETROIT, MICH.

GULF RADIO SCHOOL

Radiotelegraphy Radiotelephony
Radio Servicing

SECOND PORT } 1007 Carondelet Street
U. S. A. } NEW ORLEANS, LA.

teur traffic totals has always been made up of personals; yet in this flood official traffic predominated to the extent of 75 or 80 per cent. This was due to three factors: (1) The fact that so much official traffic existed all facilities were crowded with it alone. (2) A misapprehension in some quarters that the language of the F.C.C. ban forbade handling of personal traffic; actually, the Commission ruled just the opposite. (3) The League's policy of discouraging personal traffic going into the emergency zone, as a futile and wasteful gesture. This tied in with Number 1, in that the stations in the emergency zone were generally too busy with official business to accept outgoing personals. This whole question of personal emergency traffic is one requiring future attention, for such work is a highly useful element of amateur service.

Many valuable lessons were learned from the work as a whole. It is perhaps worthwhile to point out that two sets of benefits flow from amateur emergency work: the direct public service at the time, and the knowledge and experience and practice gained for use in the future. The major needs demonstrated by the present emergency were these: (1) The absolute necessity of preparedness in terms of the availability of emergency gear, especially self-sufficient power supply equipment. E.c. oscillators, "rubber crystals," etc., were found invaluable. (2) The need for better organization, not necessarily in terms of networks, nor based on individuals—disasters are too unpredictable for rigid, formal organization to be always effective—but in terms of modes and methods which every amateur can know and utilize when need arises. (3) The indispensable utility of working through clearing and coordinating centers, not only in networks but in casual operation as well; plans for this, as well as Number 2, are now in process of being worked out. (4) The vital importance of preliminary arrangements between individual amateurs and local relief agencies, especially the local Red Cross chapter and municipal authorities, so that when disaster strikes valuable time need not be wasted explaining and selling amateur service.

Silent Keys

It is with deep regret that we record the passing of these amateurs:

Dr. George L. Bidwell, Washington, D. C.
John E. Boddeker, Jr., W5ETD, Galveston, Texas

M. Valverde Gazan, HI2K, Ciudad Trujillo, Dominican Republic

Noble C. Lippincott, W9DLQ, Hartford, Wis.

Buckner A. McKinney, Jr., W5ATF, Dallas, Texas

Richard F. Snyder, W3FEJ, Philadelphia, Pa.

Clarence Van der Brook, W8FWG, Kalamazoo, Mich.

NEUTRALIZING CONDENSERS

National pioneered the unusual design of these neutralizing condensers. Widespread use has proved the soundness of their principle and the honest quality of their construction. All sizes have both plates insulated by Isolantite, and have heavy aluminum plates machined to a smooth rounded edge.

Three sizes are offered. The smallest (Type NC-800, Net Price \$1.80) is suitable for the RCA-800, EIMAC 35T, 50T and similar tubes. The next larger size (Type NC-150, Net Price \$3.90) is for tubes like the HK-345, RK-36, 150-T, 300-T and '852. The largest size (Type NC-500, Net Price \$7.50) is suitable for the WE 251A and similar tubes.

The chart at the left shows the capacity in mmf. for various settings of the spacing between the plates.

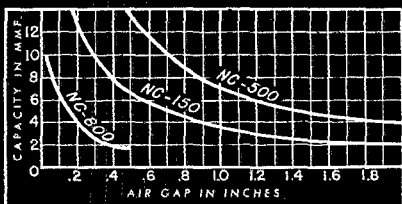

NATIONAL COMPANY, INC.

For your transmitter!

NEW IMPROVED R.F. METERS

HOT WIRE TYPE

All bakelite cases, longer scales for visibility, more rugged movements, these are the features of the new HOYT antenna meters. Used for measuring transmitter output these instruments are unaffected by frequency changes. Built for real service, these good looking meters are offered at a price that will please your pocket book.

The round style No. 576 comes in a 3 1/4" flush all bakelite case and the square model No. 577 in a semi-flush all bakelite case 4 1/4" square. Ranges are: 0/1.5, 0/3, 0/5 amps. Milliammeters to match, both square and round types are available. Ask your jobber to show you these instruments or send the convenient coupon below.

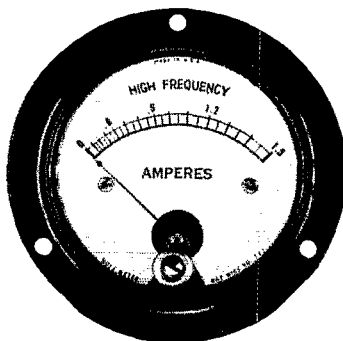
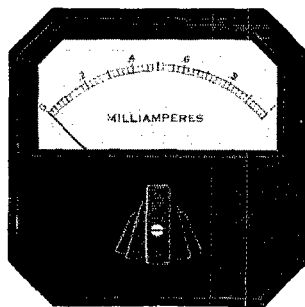

THE BURTON-ROGERS CO.

755 BOYLSTON ST.
BOSTON, MASS.

SALES DIVISION OF THE HOYT ELECTRICAL INSTRUMENT WORKS

Gentlemen:— Send me full information about Hoyt Meters

NAME..... STREET.....

CITY..... STATE.....

M&H SPECIALS

FOR *April*

Sylvania 211C Carbon Plate, Brand New. Net.....	\$6.00
50 Watt Vitrolex Sockets.....	.50
Triad 866 Tubes. Each.....	.99
Crackle 10 x 17 x 3 Finish Chassis Bases.....	.85
Chassis Bases 10 x 12 x 3.....	.75
Telegraph Keys High Grade Stamped Brass.....	.65
Masonite Panels. Per sq. ft.....	.25
2 Mfd. 1000 Volt Oil Filled Transmitting Condensers.....	.98
Kenyon 1000 Volt (through rectifier) 200 M.A. Transformers.....	3.95
Kenyon 10 Volt 6½ Amps Filament Transformers.....	1.58
Same as above with Terminal Board . . .	1.78
Kenyon 7½ Volt 6½ Amps Filament Transformers.....	1.38
Same as above with Terminal Board	1.58
Thordarson T-6877 Filter Choke 12Hy. 250 M.A.....	2.25
Thordarson Ham Special T-6878, 600 Volts each side C.T. 200 M.A. 7½ Volts 3 Amps; 2½ Volts 10 Amps; 5 Volts 3 Amps.....	2.95

National NC101X Receivers..... 129.00
 RCA ACT-20 Transmitters..... 129.50

Complete Stock of the New Kenyon "T" Line of Amateur Transformers

TRANSMITTERS — RECEIVERS — TUBES and PARTS sold on the *Budget Plan* — **No Down Payment** — Enjoy your radio while paying for it — write for details.

Our 1937 RADIO CATALOG is now ready for distribution — Send for your copy.

Write for Radio and Photographic Catalogs

M & H

SPORTING GOODS COMPANY

512 Market St. Philadelphia, Pa.

Should You Choose Radio Engineering?

(Continued from page 53)

late apparatus, make observations, and then record your data and conclusions in writing in a notebook. This kind of work much more closely resembles what you will meet later on in college and out in the research laboratories. If you like this phase of your school studies it is a favorable indication.

An important factor in radio engineering, and one not often mentioned in elementary studies, is the power of visualization. In fiction writing we might use the term "imagination." In engineering we mean "the power to see objects in space." High school subjects requiring the use of this faculty are advanced mechanical drawing and solid geometry. If you are presented with three different views of a mechanical object—let us say (1) a front view, (2) a side view, and (3) a view looking down—and you are able to construct in your mind just what the object looks like in space (three dimensions), then you possess and are using the power of visualization. In solid geometry quite a bit of this faculty is required or may be developed in you. Descriptive geometry is a continuation in this same direction later on in college. If you will take all the mechanical drawing it is possible for you to get in during high school, the chances are that your early training will be a fine preparation for the college work. If you dislike this subject and cannot do good work in it (that is, cannot visualize easily), then it is doubtful whether you will ever make a first-class engineer. In your later work in industry you will have either to build apparatus, tell someone else how to do the building, work out circuits, or read blueprints. Somewhere this peculiar faculty will be required, and sad will it be if you cannot exercise this power. Seeing an object in space and working with a radio circuit may not seem anything alike; but the same kind of brain power is required.

A somewhat different kind of analytical power is introduced in the solution of new exercises or problems in plane and solid geometry. I am not referring now to visualization but ability to unravel the tangled threads of data (which are given) and then to wind up a neatly coiled ball which we may call the solution. A great deal of an engineer's work consists in solving a problem from a huge mass of facts (many of which have no part in the solution and may be entirely irrelevant). Usually in high school the student is treated more kindly since he is only given the necessary data (and no more than are necessary) to solve a problem. The type of algebra exercises which I have in mind as bringing this faculty into play are those requiring the setting up of equations of the unknowns and not the mechanical solution of equations. The second would be a memory process while the first takes original thinking. If this type of analytical thinking comes easily it is a favorable indication.

Having finished the technical subjects we next inquire whether our scholastic standing in English or other cultural subjects has a meaning in the

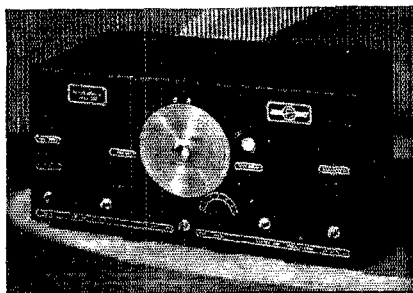

RECEIVERS • PARTS

SKY CHALLENGER..... \$69.50

ALL Receivers in Stock

Hallicrafters ■ National
Hammarlund ■ RME ■ RCA

Trade in your old receiver—Liberal allowance!

LOOK AT THESE VALUES!

TUBES . . . all guaranteed

Sylvania 211C.....	\$6.75
RCA 808.....	10.00
Amperex ZB-120.....	10.00
Amperex HF-100.....	12.50
Elmac 35T.....	8.00
Raytheon RK90A.....	17.50
Raytheon 6L6G, isolantite base.....	1.73

Tubes for all requirements in stock

PARTS . . . SPECIALS!

Bliley crystal holder.....	\$1.00
Volt-Ohmmeter 0-5, 250, 750 volts	
0-200,000 ohms, complete with test leads.....	5.95
Filament transformer for 866's.....	1.06
Bud 50 watt sockets.....	.59
Birmbach 50 watt sockets.....	.73
Meissner R.F. chokes, 1 amp.....	.88

Mail orders promptly filled

STANCOR TRANSFORMER VALUES!

750 volts each side of C.T. — 200 ma.....	\$2.88
1000-750-500 each side of C.T. — 300 ma.....	5.75

Sun Radio Co. is the exclusive distributor of Stancor products to the amateurs of the metropolitan area.

FREE TRANSMITTER HANDBOOK!

Mail this coupon today for your copy of the new Stancor BOOK OF TRANSMITTER CIRCUITS. Complete with data for R.F. and modulator stages. 5 and 10 meter rigs — peg-wee power to a kilowatt — all included in this large book of amateur transmitter circuits. IT'S FREE!

SUN RADIO COMPANY
227 FULTON STREET NEW YORK CITY

Sun Radio Co., Dept B, 227 Fulton Street, N. Y. C.
Please send me my copy of the Stancor transmitter handbook.

Name.....
Address.....
City..... State.....

Read this last
Then get your
copy and
read the
whole story
price \$1.
postpaid
A. R. K. L.
W. Hart-
ford,
Conn.

free page from
the Saga of Amateur
Radio.

HUNDRED METERS AND DOWN

Henry A. Kaupen, 2516 G, of Dulwich, Aulander, South Carolina, who on December 30th communicated with Kaupen, 2516 G, using an input of only 2577 watts to a UV-129 receiving tube with the distance given as 10,247 miles, this figured out to be 17,820 miles per watt. On January 2, 1928, contact was established with Major J. G. Swain, 6MAY, worked George H. Stratton, 2224A, in Wellington, New Zealand, a distance of 8,900 miles, with 6475 watts input, giving 17,250 miles per watt. A distance and power potential of a yacht was input, giving 17,250 miles per watt. An ordinary flashlight bulb — still stand unbroken.

before these last records were made, however, there was held the Fourth and last — National Radio Conference, which met in Washington from November 9 to 13, 1928, under the chairmanship of Secretary of Commerce Hoover. A more or less determined and concerted drive on the part of the broadcast stations to secure more territory at the expense of the amateur's 150-200 meter band had occurred prior to the opening of the conference, an address which the Secretary of Commerce, strongly advised against in his opening address. Signed against the broadcast groups, which was led by A. H. Grebe and E. J. Sigmon, were such leading engineers as Dr. A. N. Goldsmith, J. V. L. Higin, C. W. Hays and the U. S. Navy's representative, Lieut. Commander T. A. M. Craven.

The conference decided against making any changes in the amateur assignment, but Committee No. 6 on amateur matters did make the following proposals:

1. That the following minor modifications be made in the present regulations:

2. That the Department of Commerce, in its report to the House of Representatives, should state that the Department of Commerce has made a careful study of matters affecting amateur operation. Committee No. 1 on Allocation has suggested for consideration during the past year under existing regulations a year ago. Amateur operators should be permitted to use the 150-200 meter band for experimental work, to depart as they see fit, from the Department of Commerce regulations, provided the Department of Commerce is notified in advance of such departure. The Department of Commerce should be notified in advance of such departure.

3. That the Department of Commerce should be notified in advance of such departure.

4. That the Department of Commerce should be notified in advance of such departure.

5. That the Department of Commerce should be notified in advance of such departure.

6. That the Department of Commerce should be notified in advance of such departure.

7. That the Department of Commerce should be notified in advance of such departure.

8. That the Department of Commerce should be notified in advance of such departure.

9. That the Department of Commerce should be notified in advance of such departure.

10. That the Department of Commerce should be notified in advance of such departure.

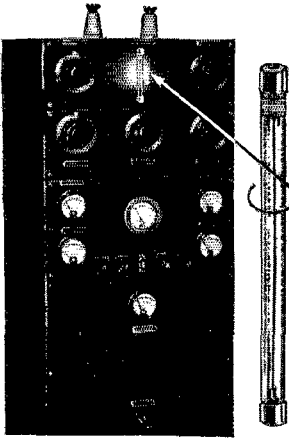

SUNCO NEON TUNING WAND

More D.X. from your
present Xmitter

With it you'll get more watts output from your rig. Indicates current in radio frequency circuits without any direct connection to the circuit. On all transmitters from 1 to 1,000 watts install as illustrated.



Uses practically no power. Will not burn out. Used for antenna meter, resonance, neutralizing, tracing R.F. in power supply and modulation meter.

A low-cost, high quality instrument for increasing transmitter efficiency.

\$1.50 EACH. Sent post paid anywhere in U. S. A. Send for yours now

(New Improved Model No. 5146)

Clear glass tube 8" x 1/4" dia. Contains highly purified neon. Red glow creeps up 6" electrode and indicates strength of current. Super-sensitive to R.F.

SUNDT ENGINEERING COMPANY

(Affiliate Littelfuse Labs)

4246 Lincoln Avenue

Chicago, Illinois

RADIO

ENGINEERING, broadcasting, aviation and police radio, servicing, marine radio telegraphy and telephony, Morse telegraphy and railway accounting taught thoroughly. Engineering course of nine months duration equivalent to three years of college radio work. School established 1874. All expenses low. Catalog free. **DODGE'S INSTITUTE,** Day Street, Valparaiso, Indiana



**NEW
HOLDER
DESIGN**
15 SECONDS
TO INSTALL
CRYSTAL

For All Bands

**GREATER
STABILITY**

Plugs in 5 prong
tube socket

Beautiful
Appearance

MODEL AH HOLDER \$1.00

At your dealer or direct

HIPOWER LOW DRIFT CRYSTALS:
within 10 kc. or Choice of stock

AH-10, 1700-3500 Kc. bands \$2.35

AH-10, 7000-7300 " band 3.90

write for new Literature

Hipower "Low Drift" Broadcast and Commercial
Crystals Are Approved by F.C.C.

Hipower Crystal Co., 2035 Charleston St., Chicago

T. R. McELROY

WORLD'S CHAMPION RADIO TELEGRAPHER

23 Bayside Street, Boston, Mass.

MAC KEY @ \$7.95 a real speed key.

MAC KEY DELUXE @ \$15.00.

MAC CORD @ \$1.00 speed key cord.

MAC CASE @ \$3.95 speed key case.

MAC OSC @ \$3.95 ac/dc oscillator. Tone control.

If u hv Mae Key wri me fo xmy ipt & dsrb lfn.

All my stuff emcy gad best pduts obl. 73 Mac.

likelihood for success in engineering. It may seem futile to argue that ability to get good marks in these cultural subjects indicates very much. While observations indicate that many very successful radio engineers were extremely poor English students, it might well be that if their positions had required very much writing they would not have been successful. On the other hand, good all-round students were found to have received excellent English marks and in addition were fine engineers so that we see there are the two cases of (1) those who can be successful at engineering and that alone; and (2) those who could be successful at many things but who chose engineering by preference. Let us put this in another way: Some of us will only be successful in a certain few vocations and we are trying here to bring together what some of these requirements are in radio engineering. If you find it perfectly enjoyable to substitute a major interest in English or history for one or all of the sciences, then your true interest in technical subjects may well be questioned.

YOUR DAILY LIFE AS A CRITERION

Perhaps there are some indications in your daily living which will show more truly where your interests lie than your mere indulgence in the hobby of radio. When there is an absorbing interest in politics or social questions this may not be a favorable sign. Especially unfavorable would be the trait of preferring to sit down and read good literature (history or fiction) rather than building objects with your hands or working repairing a car or around machinery. This does not mean that I say to shun doing any of these things which may be mentioned as unfavorable indications of success in engineering; but rather that if your mind naturally runs to technical things you find most of your time taken up with technical or mechanical things. To prevent being one-sided it is necessary to read the informative parts of the daily newspaper as well as good literature. Nevertheless, it is an excellent indication if you can quickly and easily build things with your hands (such as lathe work, if one is available) as well as understand verbal descriptions of mechanical objects.

No discussion would be complete without a reference to health, optimism, and personality. No vocation is worth the price of sacrificing one's health, and the demands made on this resource are tremendous in four years of intensive engineering study in college.

A SELF-EXAMINATION

It seems that the best way to summarize all the previous material would be to give an opportunity for each interested reader to take a self-examination on his fitness to prepare for the vocation of radio engineering through four years of collegiate training. I again caution against the impossibility of making a sure-fire vocational success prediction, but believe the test given below will help indicate where you stand. Inability even to answer some of the questions will indicate the need for

ANNOUNCING - UHX-10 TRANSMITTER

Fixed - Portable - Mobile

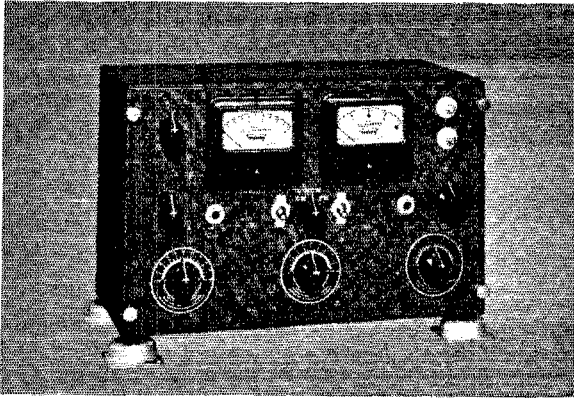

FOR
AMATEUR, COMMERCIAL, EMERGENCY
SERVICE

1500 — 60,000 KC. COVERAGE
CRYSTAL OR ELECTRON COUPLED
CONTROL
A.C. OR BATTERY OPERATION
PHONE — MCW — CW OPERATION
NOMINAL RATING 10 WATTS OUTPUT
COMPACT — LIGHT — RUGGED

WRITE FOR FULL DETAILS

HARVEY RADIO LABORATORIES, INC.

12 Boylston St., Brookline, Mass.

Export: 25 Warren Street, New York City.

Cable: "Simonrice"



NO. X-187

7 1/2 volt "A" Battery

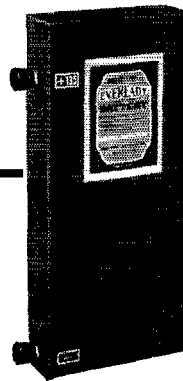

NO. X-188

135 volt "B" Battery

THESE ARE THE BATTERIES used in National Broadcasting Company's Microwave Transmitters:*

No. X-187 is an "A" Battery for use with acorn tubes. 2 25/32" long, 2 3/16" wide, 3 7/8" high. Weight, 1 lb. 3 oz.

No. X-188 is a "B" Battery for use with acorn tubes. 8 9/16" long, 1 1/4" wide, 3 7/8" high. Weight, 2 lb. 3 oz.

NATIONAL CARBON COMPANY, INC.

General Offices: New York, N. Y. Branches: San Francisco, Chicago.

Unit of Union Carbide  and Carbon Corporation

*See QST, August, 1936, page 66.

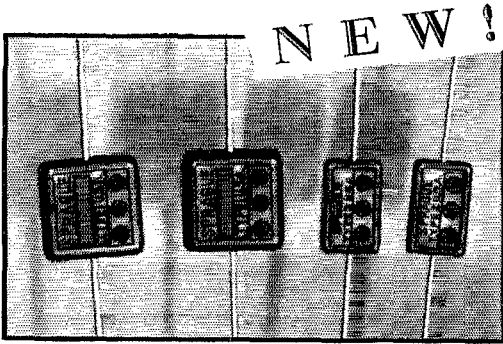

SPRAGUE MICA CONDENSERS

● STAMPED WITH CAPACITY RATINGS

Now you can buy molded Mica Condensers made and guaranteed by the world's largest manufacturer of quality condensers — Mica Condensers that have the highest resistance to moisture — Mica Condensers with voltage ratings you can rely upon and with an exceptionally low and stable power factor. Note the heavy, flexible wire leads that can be looped for "eyelet" mounting where desired.

*** **FREE** Let us send you the new Sprague catalog, just printed, containing full details on these new Mica units, new Sprague Trimmers, rectangular transmitting condensers, etc., etc. ALSO condenser facts and buying information that will prove invaluable. A COMPLETE Condenser Manual in the handiest possible form. Write today!

SPRAGUE PRODUCTS CO.

North Adams, Mass.

USE SPRAGUES and Note the Difference

NEW

Mounted 20 Meter Crystal

The new type LW20 mounted crystal has been developed for direct crystal control in the twenty meter band, employing an entirely new crystal and mounting. The crystal is highly active and may be used with all conventional circuits with resultant high power output and stability.

The New LW20 Mounting is moulded from a high quality low loss bakelite, employs tube prong pins for tube socket mounting, is modernistic in design and beautiful in appearance. Supplied within 20kc's of your specified frequency **\$5.90** from 14 to 15 Mc.

Purchase this new unit at your dealer after April 15th, or order direct

THE VALPEY CRYSTALS
377 Summer Street Medway, Mass.

beginning to think along these lines. Make an estimate of your standing in the following:

1. Do you read, re-read, study and endeavor to understand the technical articles of *QST*, the *A.R.R.L. Handbook*, radio textbooks, etc.? (Give yourself not more than 10 points on this question.)
2. Do you keep some form of laboratory notebook in which you record the experiments, apparatus circuits you try out, results, remarks, etc., for your radio hobby? (Give yourself not more than 5 points on this question.)
3. Do you perform real technical work with your station? (Not more than 10 points. To get *any* points on this question you must have a Class-B license at least.)
Remarks: The emphasis here is not so much on how expensive apparatus you have but rather on what use is made of what you have. Even a simple one-tube receiver has at least five possible variables (plate, grid and filament voltages, inductance, capacity) whose effects in changing magnitudes are sufficient to give several long experiments, and plenty of notebook writing.
4. Estimate your ability as a school student (10 possible points).
Remarks: If fast to learn and slow to forget, give 10 points. If you learn fast and forget quickly, 5 points. If slow to learn yet slow to forget, 4 points. Give no points if you do not stand in the upper third of your class scholastically.
5. The standing of the particular school you are attending as a preparatory place for college (10 possible points).
6. Degree of participation in school activities (5 possible points). This refers to non-radio, non-technical interests, such as school paper editorial board, drama, etc.
7. The accuracy, skill, speed, and notebook report in the school physics and chemistry laboratory (5 possible points).
8. Power to visualize (10 possible points).
9. Power to analyze (10 possible points).
10. Knowledge of how to take lecture notes, organize and distribute your time in preparing homework, study effectively, etc. (5 possible points).
11. Health (5 possible points, deduct for glasses.)
12. Perseverance (5 possible points).

Remarks: This means, can you stick to a thing and see it through in the face of adversity?

13. Skill in using your hands to build things (10 possible points). If you rarely make or repair things, zero credit.

The passing grade for this examination has been arbitrarily set at 70 points.

An important factor left out, on account of inability to devise a suitable standard for rating, is that of common sense, although this may be considered to come under some of the previous traits.

You should be very critical of your abilities in answering this questionnaire, since the purpose of

Announcing—"Bridge-type" construction at a fraction of former price!

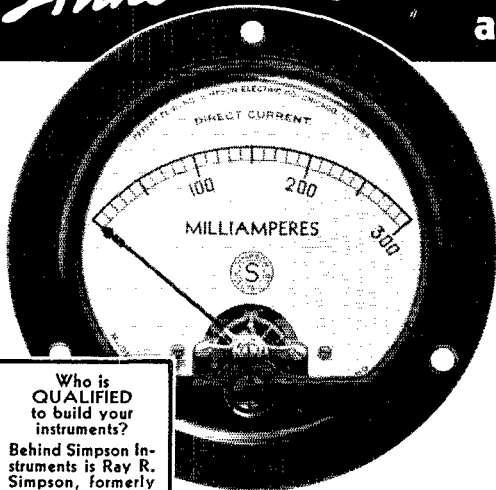

HERE is the answer to one of your toughest questions: "Shall I sacrifice quality and accuracy in panel instruments to hold down costs?—or shall I pay the premium for instruments of lasting quality?"

No longer is it necessary to do either! At prices no higher than you have been paying for the ordinary run of panel instruments you can now have the bridge-type construction and soft iron pole pieces that have been used only in instruments priced 50% to 100% higher.

Modern production methods have made this almost incredible value possible—instruments that will stay accurate year after year—built by an instrument manufacturer of highest reputation—yet priced within the reach of any amateur.

Net price on most A.C. and D.C. ranges **\$3.75** to amateurs

Thermo-Couple types at the new low price of...\$6.55
 SIMPSON ELECTRIC CO., 5216 W. Kinzie St., Chicago, Ill.

Who is QUALIFIED to build your instruments?
 Behind Simpson Instruments is Ray R. Simpson, formerly president of Jewell Electrical Instrument Co., and collaborating with him are many of the men who once helped to build the Jewell reputation for unmatched precision and ruggedness. Who could be better qualified?

SIMPSON

Instruments that STAY accurate

MAIL THIS COUPON FOR FACTS
 Simpson Electric Co., 5216 W. Kinzie St., Chicago
 Send Facts About Simpson Instruments—

Name _____ Call _____
 Address _____

Everything in Radio FOR THE AMATEUR

TERMINAL RADIO CORP.

80 CORTLANDT STREET, N. Y. C.
 BILL FILLER ■ ADOLPH GROSS

NATIONAL RADIO PRODUCTS

OHMITE

BLILEY

EIMAC

the hallicrafters Inc.

T. R. McELROY

SHURE

AMPEREX

KENYON TRANSFORMER

BIRNBACH

BRUSH

WESTON

TURNER

Hammarlund

RCA

IBC

MAGIC SPEAKER

TRIMM RADIO MFG. CO.

TRIPLET

RME

CARDWELL

AEROVOX

SPEED-X

COTO-COIL

AMPHENOL

ASTATIC

THORARSON

E. F. JOHNSON

W.D.

CD

SIMPSON ELECTRIC CO.

VIBROPLEX

STROMBERG-CARLSON

MAZDA

JAYCO

HEAT

TRIMM

TRIPLET

TRIPLET

TRIPLET

Bruno's NEW LOW COST

WIDE RANGE
HIGH OUTPUT
HUMLESS MICROPHONE

Not just another Mike!

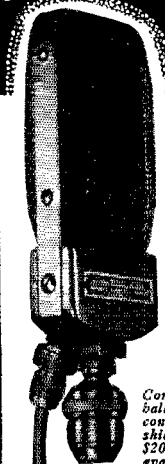

Based on an exclusive Bruno construction feature, the rugged Velotron embodies the high fidelity characteristics of the velocity, surpasses the output of the diaphragm type crystal and is as low priced as the best carbon. The Velotron is a true velocity microphone utilizing a static, instead of the customary magnetic field.

Check these outstanding characteristics found only in the

BRUNO VELOTRON

- ☆ Highly directional
- ☆ Low feedback level
- ☆ Variable Frequency response (30 to 14,000 cycles)
- ☆ Output level — 50 db. (Zero level 6 milliwatts)
- ☆ Absolutely humless
- ☆ Thoroughly shielded
- ☆ Not affected by varying temperatures or changing atmospheric conditions.

Complete with shock absorber, ball swivel, detachable cable connector, and 8 feet of single shielded cable. Model A only \$20.00 list. Model H also available for portable use.

Get your jobber to demonstrate the New Velotron to you! . . . or write direct for complete descriptive catalog.

ONLY \$20 LIST



it is to show up your weaknesses. Not many can get a perfect scoring; but those who do fail need not abandon hope in choosing radio engineering as a profession. Perhaps up to now you have been traveling up a blind alley and this material will help set you back on the right road, and assist you in making a success of what might have been a failure. If you do decide that radio engineering is not the vocation for you to follow, you can still go into other phases of the same general field, such as commercial operating, radio sales and service, the business end of broadcasting, etc. There need be no feeling of inferiority in making such a choice. All types of workers are equally necessary in making the wheels of this world go round. After all, success in living consists in bringing to your life the richest experiences possible to you — which means developing your latent abilities and aptitudes to their utmost. Everyone has this duty of service to society. Success is never measured in terms of salary or prestige. Your best is the most you can do; and with that you must be content, for that is your success.

MISCELLANEOUS SUGGESTIONS

Now we go back again to those bent on preparing for college, to give a few miscellaneous suggestions that may prove helpful. If you are going to study any foreign language I am quite sure that technical German will be found more useful than any other, including French. The reason for this statement is that the German library of technical books, especially in the various electrical engineering and physics fields, is one of the most comprehensive in the world.

Learning to typewrite by the touch system, and the eventual ownership of a portable typewriter, will be found worth all the effort needed and can often be taken up in high school. Most graduates of colleges these days have to find their own jobs and often this is accomplished by writing effective letters to industrial firms.

There would be a real advantage in knowing how to take notes in shorthand were it not such a long, tedious job to get up speed. The reason for this statement is that advanced subjects in college are often given in lecture form from a variety of sources not available to the student. This will be clearer if you are reminded that the latest material on a subject found in a textbook is at least two years behind the most recent developments; and in the case of periodicals the time lag may be anywhere from three months to a year and a half. This is caused by the time needed to write up the important results of a research project for publication, acceptance for publication, and still later finding room in the technical periodical for actual appearance of the article. Through various kinds of technical meetings the college professor has access to all this material much sooner than periodical readers (if it ever does reach printed form) so that the use of shorthand would enable you to get a much better set of notes. However, not many of us can find time to learn shorthand.

Now, do you still think you should be a radio engineer?

THE SUPER SKY RIDER

WE HAVE THE NEW SKY CHALLENGER

and we're proud to recommend this sensational new communications receiver to every amateur as the greatest value we've ever had! It has the features you want and need, performance equal or better than many higher priced receivers. This 9-Tube Super covers all the active amateur bands including the 10 meter band. Electrical Band Spread. Iron Core I. F. Transformers. Crystal and Speaker extra. Write today for complete specifications.

\$69.50

Now, more favorable Time Payment Plan

E. E. FORBES AND SONS
PIANO COMPANY
403 No. 20th St. Birmingham, Ala.
EVERYTHING IN RADIO PARTS AND SUPPLIES

the haitcrafters inc.

THE SKY CHALLENGER

THE SKY CHALLENGER

THE SKY CHIEF

THE SKY CHIEF

THE SKY BUDDY

THE SKY BUDDY

Building a New Transmitter? . . .

USE G-E PYRANOL CAPACITORS

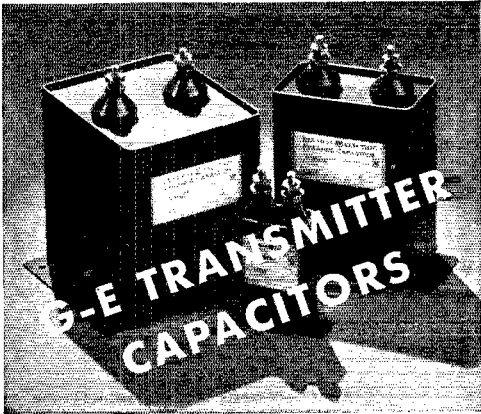

Be sure that your new rig contains G-E capacitors —because they will stand the gaff of hard service through long periods of use. G-E capacitors have these outstanding advantages.

1. They are all treated with Pyranol—a new General Electric synthetic material that assures permanence of their high dielectric strength and operating characteristics.
2. Every unit must pass a high-voltage test of double rated voltage. You can operate them continuously at 10 per cent above rated voltage.
3. They are hermetically sealed and leak-tested under vacuum.
4. They are very small in size, and fireproof.

You can get these Pyranol capacitors from your nearest dealer. For more information, write for Bulletin GEA-2021, Radio Dept., General Electric, Schenectady, N. Y.

360-120

GENERAL ELECTRIC

Radio Operator's
Course

Complete in
Telegraphy—
Telephony

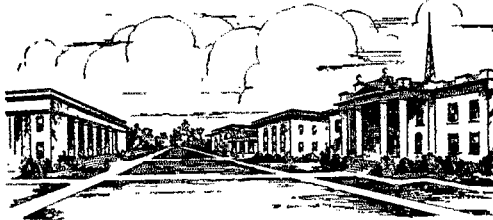

Practical
Experience
Studio—
Transmitter—
Announcing

AVIATION RADIO A new complete training embracing advanced work for amateurs, or operators—twelve months' study required for the average amateur to graduate—excellent opportunity for men interested in commercial airlines. Applicant for enrollment must be high school graduate, or college student. We confer degree—Science of Radio—to graduates of this course. If interested, write for aviation radio details.

P. A. C. is an endowed, educational institution — not privately owned, not operated for profit, college rank maintained. Course consists of maximum knowledge necessary to secure Commercial Telegraph Second-class, and Radio-telephone First-class government licenses. Course includes Wireless Code, Radiophone, Announcing, Microphone-Studio Technique, Service, Television, Police, and Aeronautical Radio. We are authorized to teach RCA texts. At the completion of course you receive practical studio technique experience in our commercial broadcast studios located in the administration building, and experience as an operator on K P A C (500-Watt Commercial transmitter located on the campus, owned and operated by the college), and inter-departmental marine communication experience.

If interested, write for Bulletin R

PORT ARTHUR COLLEGE ■ **PORT ARTHUR (World-known port) TEXAS**

Power
X cut

**O. C. L.
Control Crystals**

High
Output

Unconditionally Guaranteed

7000 KC = KC. . \$1.85 3500 or 1750 = 5 KC \$1.50
ATCUT—40-80-160 = 5 KC. 2.25

OMAHA CRYSTAL LABORATORIES

Jobbers write: W9JRY, NORTH PLATTE, NEBR. W9CPM

SICKLES COILS

ALL TYPES OF RF AND IF WINDINGS

Manufactured by

F. W. SICKLES COMPANY

300 Main Street

Springfield, Mass.

Where to buy it

A directory of suppliers who carry in stock the products of these dependable manufacturers.



ALBANY, N. Y. Uncle Dave's Radio Shack 356 Broadway

BALTIMORE, MD. 3 North Howard St.
Radio Electric Service Company

BOSTON, MASS. Radio Shack 46 Brattle Street

HARTFORD, CONN. 227 Asylum Street
Radio Inspection Service Co.

NEWARK, N. J. 219 Central Ave.
Wholesale Radio Service Co., Inc.

NEW YORK, N. Y. 51 Vesey St.
Gross Radio, Inc.

NEW YORK, N. Y. 12 West Broadway
Harrison Radio Co.

NEW YORK, N. Y. 103 W. 43rd St.
Harvey's Radio Shop

NEW YORK, N. Y. 100 Sixth Ave.
Wholesale Radio Service Co., Inc.

READING, PENN. 404 Walnut St.
George D. Barbey Company

SPRINGFIELD, MASS. T. F. Cushing 349 Worthington St.



ALBANY, N. Y. Uncle Dave's Radio Shack 356 Broadway

BALTIMORE, MD. 3 North Howard St.
Radio Electric Service Company

BOSTON, MASS. H. Jappe Company 46 Cornhill

BOSTON, MASS. Radio Shack 46 Brattle Street

BURLINGTON, VERMONT
Vermont Hardware Co., Inc.

CAMDEN, NEW JERSEY 811 Federal Street
Radio Electric Service Company

GREENWICH, CONN. 252 Greenwich Ave.
Mead Stationery Company

HARTFORD, CONN. 227 Asylum Street
Radio Inspection Service Co.

MONTREAL, CANADA 285 Craig Street, West
Canadian Electrical Supply Co., Ltd.

NEWARK, N. J. 219 Central Avenue
Wholesale Radio Service Co.

NEW YORK, N. Y. 460 W. 34th St.
Bruno-New York, Inc.

NEW YORK, N. Y. 136 Liberty St.
Sanford Samuel Corp.

NEW YORK, N. Y. 100 Sixth Avenue
Wholesale Radio Service Co.

NEW YORK, NEW YORK 12 West Broadway
Harrison Radio Company

NEW YORK, NEW YORK 124 E. 44th Street
Grand Central Radio, Inc.

PHILADELPHIA, PENN. 10 S. 10th Street
Eugene G. Wile

PHILADELPHIA, PENN. 117 North 7th St.
Raymond Rosen & Company

PHILADELPHIA, PENN. 512 Market Street
M & H Sporting Goods Company

PHILADELPHIA, PENN. 3125 N. Broad Street
Radio Electric Service Company

PHILADELPHIA, PENN. N.E. Corner 7th & Arch Streets
Radio Electric Service Company

PITTSBURGH, PENN. 603 Grant Street
Cameradio Company

READING, PENN. 8th & Elm Streets
Bright & Company

SPRINGFIELD, MASS. 349 Worthington Street
T. F. Cushing

Where to buy it

A directory of suppliers who carry in stock the products of these dependable manufacturers.

SPRINGFIELD, MASS. 1540 Main Street
S. S. Kresge Radio Department

WASHINGTON, D. C. 938 F Street, N. W.
Sun Radio & Service Supply Co.

RME
RECEIVERS -- PRE SELECTORS
AMATEUR RADIO EQUIPMENT
RADIO MFG. ENGINEERS, Inc.
PEORIA, ILLINOIS

ALBANY, NEW YORK 356 Broadway
Uncle Dave's Radio Shack

BINGHAMTON, NEW YORK 25-27 Sturges Street
Radio Testing Station

BUFFALO, NEW YORK 216 E. Genessee Street
Dymac Radio

HARTFORD, CONNECTICUT 210 Chapel Street
Stern Wholesale Parts Company

NEW YORK, NEW YORK 12 West Broadway
Harrison Radio Company

PITTSBURGH, PENNSYLVANIA 603 Grant Street
Cameradio

ROCHESTER, NEW YORK 244 Clinton Ave., N.
Radio Service Shop

RAYTHEON
TRADE MARK
AMATEUR TUBES

ALBANY, NEW YORK 356 Broadway
Uncle Dave's Radio Shack

BOSTON, MASS. The Radio Shack 46 Brattle Street

BOSTON, MASS. Selden Radio Company 28 Brattle Street

BUFFALO, NEW YORK 326 Elm Street
Radio Equipment Corp.

CONCORD, NEW HAMPSHIRE 80 N. State Street
Carl B. Evans

NEWARK, NEW JERSEY 219 Central Street
Wholesale Radio Service Co.

NEW YORK, N. Y. 12 West Broadway
Harrison Radio Company

NEW YORK, N. Y. 103 W. 43rd St.
Harvey's Radio Shop

NEW YORK, N. Y. 100 Sixth Avenue
Wholesale Radio Service Co.

TRIPLET
INSTRUMENTS

ALBANY, N. Y. 356 Broadway
Uncle Dave's Radio Shack

BOSTON, MASS. Radio Shack 46 Brattle Street

BOSTON, MASS. Selden Radio Company 28 Brattle St.

MONTREAL, CANADA 285 Craig Street, West
Canadian Electrical Supply Co., Ltd.

NEWARK, N. J. 219 Central Ave.
Wholesale Radio Service Company

NEW YORK, N. Y. 100 Sixth Avenue
Wholesale Radio Service Company

PITTSBURGH, PENN. 603 Grant Street
Cameradio Company

READING, PENN. 404 Walnut Street
George D. Barbey Company

Want a sky-hook? The Westinghouse company has them—and for only two bucks. If you don't believe it, they're listed in the current catalog. W3VG sent us page 377 to prove it.

New Receiving Tubes

(Continued from page 56)

The above ratings apply to condenser-input filters. Octal base, 5 pins.

6A5G

This tube is a triode power amplifier with indirectly-heated cathode. Characteristics are identical with those of the 6A3 and 6B4G (given in the *Handbook*) except for the single-tube Class-A power output rating, which is 3.75 watts in the case of the 6A5G. Octal base.

6C8G

The 6C8G is a dual triode made particularly for phase-inverter service. Separate cathodes are provided for each triode section. This tube looks as though it might be useful in speech-amplifier applications. Tentative ratings and characteristics are:

Heater voltage.....	6.3 volts
Heater current.....	0.3 amp.
Plate voltage.....	250 volts max.
Grid voltage.....	-4.5 volts
Plate current.....	3.1 ma.
Plate resistance.....	26,000 ohms
Mutual conductance.....	1450 micromhos
Amplification factor.....	38

Octal base, eight pins.

6U7G

The 6U7G is identical with the 6D6 in characteristics, differing only in having an octal base.

6V7G

Another octal-based equivalent. The 6V7G duplicates the present type 85.

6Y7G

Still another equivalent, this time of the present type 79. Octal base.

25A7G

The 25A7G is a combination rectifier and pentode power amplifier for a.c.-d.c. sets. It is similar to the 12A7 but with higher ratings. Following are tentative characteristics and ratings:

Heater voltage.....	25 volts
Heater current.....	0.3 amp.

Rectifier section.

Max. a.c. plate voltage.....	125 volts
Max. d.c. output current.....	75 ma.

Pentode section; Class-A amplifier:

Plate voltage.....	100 volts
Screen voltage.....	100 volts
Grid voltage.....	-15 volts
Grid current.....	20.5 ma.
Screen current.....	4 ma.
Load resistance.....	4500 ohms
Power output.....	0.77 watts
Total harmonics.....	9 percent

Octal base, 8 pins.

25L6G

The 25L6G is an octal-based duplicate of the 25L6, described in January, 1937, *QST*.

THE RADIO AMATEUR'S *Library*

For some time our advertising in *QST* has carried a by-line reading "Number..... in the series entitled Radio Amateur's Library." Many requests have been received for copies of this list and now we present it in *QST* in its complete form — to give a comprehensive picture of our publishing services to the amateur.

No.	Title	Price
1.	<i>QST</i>	\$2.50 per year*
2.	List of Stations	Pre-war <i>Out of Print</i>
3.	Map of Member Stations	Pre-war <i>Out of Print</i>
4.	Operating an Amateur Radio Station (Formerly called Rules & Regulations of Communications Dept.)	Free to members; to other 10c
5.	The Story of The A.R.R.L.	<i>Out of Print</i> See No. 13
6.	The Radio Amateur's Handbook	\$1.00**
7.	The Log	35c each; 3 for \$1.00
8.	How to Become a Radio Amateur	25c
9.	The Radio Amateur's License Manual	25c
10.	Hints & Kinks for the Radio Amateur	50c
11.	Lightning Calculators:	
	a. Radio (Type A)	\$1.00
	b. Ohm's Law (Type B)	1.00
	c. Wire Data (Type C)	50c
	d. Decibel (Type D)	50c
	e. Parallel Resistance — Series Capacity (Type E)	50c
	f. Resistance Calculator (Type F)	50c
12.	Amateur Radio Map of the World	1.25
13.	Two Hundred Meters and Down: The Story of Amateur Radio	1.00

*In the United States and Possessions and Canada.
Other Countries \$3.00 per year.

**Postpaid in Continental U.S.A. — \$1.25, postpaid, elsewhere.

**THE AMERICAN
RADIO RELAY LEAGUE, INC.**
West Hartford, Connecticut

HAM-ADS

(1) Advertising shall pertain to radio and shall be of nature of interest to radio amateurs or experimenters in their pursuit of the art.

(2) No display of any character will be accepted, nor can any special typographical arrangement, such as all or part capital letters be used which would tend to make one advertisement stand out from the others.

(3) The Ham-Ad rate is 15¢ per word, except as noted in paragraph (4) below.

(4) Remittance in full must accompany copy. No cash or contract discount or agency commission will be allowed.

(5) Closing date for Ham-Ads is the 25th of the second month preceding publication date.

(6) A special rate of 7¢ per word will apply to advertising which, in our judgment, is obviously non-commercial in nature and is placed and signed by a member of the American Radio Relay League. Thus, advertising of bona fide surplus equipment owned, used and for sale by an individual or apparatus offered for exchange or advertising inquiring for special equipment, if by a member of the American Radio Relay League takes the 7¢ rate. An attempt to deal in apparatus in quantity for profit, even if by an individual, is commercial and takes the 15¢ rate. Provisions of paragraphs (1), (2), (4) and (5) apply to all advertising in this column regardless of which rate may apply.

Having made no investigation of the advertisers in the classified columns, the publishers of *QST* are unable to vouch for their integrity or for the grade or character of the products advertised.

QUARTZ—direct importers from Brazil of best quality pure quartz suitable for making piezo-electric crystals. Diamond Drill Carbon Co., 719 World Bldg., New York City.

RADIO engineering, broadcasting, aviation and police radio, servicing, marine and Morse telegraphy taught thoroughly. All expenses low. Catalog free. Dodge's Institute, Byrd St., Valparaiso, Ind.

NATIONAL—Hammarlund, RCA-RME used sets, 60% off list. W3DQ, 405 Delaware Ave., Wilmington, Del.

QSL's, W2SN, Helmetta, N. J.

CLASS B transformers—Universal for two or four 46's, 61.6's, 210's, 800's, etc., \$7.75 pair postpaid. 70 watts audio from 46's, 100 watts from 10's. Write for details. W8UD, Douglas, Mich.

CALLBOOKS—new DX calls, new prefixes, thousands of new W and VE calls, in the Spring, 1937 Radio Amateur Call Book. Sent postpaid \$1.25, or a whole year (four issues) for \$4. (In foreign countries \$1.35 and \$4.35.) Your call and QRA printed in large type \$1 per year. Radio Amateur Call Book, 610 S. Dearborn, Chicago.

TELEGRAPH speed keys in kit form, only \$2.89. A post card brings full information. Electric Specialty Mfg. Co., PO Box 645, Cedar Rapids, Iowa.

QSL cards, two color, cartoons, snappy service. Write for free samples today. W1BFF, 16 Stockbridge Ave., Lowell, Mass.

THOUSANDS of crystals for 160 and 80 meter bands, 75¢ each postpaid. Faberadio, Sandwich, Ill.

RECONDITIONED receivers: Always a wide selection because of our immense time payment sales. Penny post card brings list. Radiolab, 1515 Grand, Kansas City, Mo.

GENERAL Electric 24/750 volt 200 mill ball bearing dynamos with filters, \$25. On twelve volts deliver 375.6-15 volt 500 watts Westinghouse Aircraft with propeller, \$10, 500 watts 500 cycles with exciters \$8. Slightly used, \$6, 900 cycle 200 watts \$15. Henry Kienzie, 215 Hart Blvd., Staten Island, N. Y.

AMATEUR radio, commercial radiotelephone and radiotelegraph licenses, complete training. Resident and correspondence courses. Every graduate a licensed operator. N. Y. Wireless School, 1123 Broadway, N. Y.

TRADE—E-flat alto saxophone, nine tube Ham receiver, Philco auto radio, 22 coil, etc., for HRO. Make offer. W. Horton, Haines City, Fla.

WANTED: AC generator 110-volt 60-cycle 5 k.w. or more. All letters answered. W4AFK.

QSL's. Free samples. Printer, Corwith, Iowa.

QSL's—SWL's. Cartoons. Free samples. Theodore Porcher, 7708 Navaho St., Philadelphia, Penn.

SELL: New National ACSW3 receiver and power supply, 7 sets coils, tubes, \$28. W2CIZ.

QSL's, SWL's, fb 3 color, 75¢ and up per 100. Lapco, 344 W. 39 St., Indianapolis, Ind.

SALE: National ACSW3, power supply (National), tubes, five sets bandspread coils. Make offer. W3AFC.

TRADE one k.w. rig for HRO receiver or large 110 AC generator or what have you. W4DND, Winterville, Ga.

QST back numbers 1916 to 1925. Make offer one or all. Joseph Casey, 15 Poplar St., Melrose, Mass.

BREAK-In audio oscillator and relay control box complete. Write W2BSP.

TRANSMITTERS constructed. Superior workmanship. Give complete information. Sectional enclosed racks for sale. Write. Howard Radio, 5514 Lake St., Chicago. (Columbus 9819.)

QSL's—2 color—\$1 hundred. Samples. Stamp. W8NOS.

McMURDO-SILVER Custom Masterpiece receiver, power unit, speaker. Very efficient. Glenn Watt, Chanute, Kansas.

CRYSTALS: Unconditionally guaranteed, X cut, 160-80 meters, within ten kilocycles, \$1.50. Exact frequency, one inch square, \$2.50. Small X cut, 80 meter semi-finished blanks, including carborundum, three for \$1.20. Dustproof, plugin holders, 85¢. William Threm, W8FN, 4021 Davis Ave., Cheviot, Ohio.

CRYSTALS—1" square 80 X-cut \$1, Lo-Drift \$1.25; 160 X-cut \$1.25, Lo-Drift \$1.50. Within 15 k.c. of specified frequency. Guaranteed. Wolverine Crystal Service, Calumet, Mich.

QSL's—SWL's. Printed to your specifications. Samples? (Stamp) W8DED, Holland, Mich.

MEMBER W.A.C. (or W.A.S.) Club 3-color sign, 25¢. W8DED DANGER sign, 10¢. W8DED.

BLILEY crystals. Patronize W8DED.

SELL 53-53, RK23, 803 all-metal transmitter, three highly filtered power supplies, transmitter ready for phone. Also unused Amperite Velocity mike and modulator parts. On display at WIBFT. Write for photos and details to W1AXW, 31 Sixth St., Dover, N. H.

WANTED: 4-5 h.p. motor, burned out; Weston photometer, dual type preferred; Kodak Pupille or similar. W1FGO, Norwich, Vt.

THERMOCOUPLE ammeters repaired, \$2.50. W9GIN, 412 Argyle Bldg., Kansas City, Mo.

WANTED: Superhet, W6MYK, Phoenix, Ariz.

SALE—Complete fone station including receiver, 25 to 30 watts output—all-metal chassis—\$75. W7CSD, 1607 Maple, Pullman, Wash.

TRANSFORMERS, chokes, custom-built. Write for list. Special—Husky 3/4 KVA Plate Transformers, unceased—\$9.50, cased in compound—\$12. Baker Engineering, Fort Wayne, Ind.

QSL's (different) 300 for \$1.50 postpaid. Letterheads, something better. Write Varcos Printery, Honesdale, Penn.

SW3, National power supply, 20-40-80-49 bands, tubes, complete—\$25. W21BJ.

SILVER 5 C with xtal, \$35. Albert Pilch, 281 Missouri St., San Francisco, Calif.

WANTED: Good Ham receiver. Prefer FBXA. Kramer, Garnaville, Iowa.

SELL: xmtr with power supply, \$50. Receiver, \$20. Petersen, 159 Radford St., Yonkers, N. Y.

BETTER QSL's—SWL's. Fritz, 203 Mason Ave., Joliet, Ill.

WANTED—Receiver in A-1 condition. Super preferred. W9LM, Kansas City, Kansas.

CRYSTALS: Nice stock Eidson's T9 40 meter crystals, \$1.60. Satisfaction Guaranteed. Ceramic holders, \$1.10. C.O.D. orders O.K. W4DDF, Stratford Ave., Nashville, Tenn.

WANTED—old Model receiving sets manufactured by Chicago Radio Lab. such as CRL Paragons, Ampliflons, Multiceivers, etc. What have you? Zenith Radio Corp., Adv. Dept.

150 loose leaf log sheets with your call and QRA, \$1. prepaid Kramer, Gay Bldg., Madison, Wis.

FOR sale, Escoc motor-generator, 500 volts, 300 ma., \$14, f.o.b. W2BMO.

CRYSTALS—special Spring offer. For a limited time only, 80 and 160 meter crystals mounted in new type shielded dust-proof holder, only \$1.25. Highest quality and fully guaranteed. Stock up now. White Radio Lab., Standpoint, Idaho.

SELLING out. Send for list. W1IIT.

SELL two new matched 211D's for \$25 postpaid. W7GEQ, Goldbeach, Oregon.

INTERNATIONAL stamp exchange for licensed hams only. W7GEQ, Goldbeach, Oregon.

QSL's. Finest in country. Free samples. Maleco, 1512 Eastern Parkway, Brooklyn, N. Y.

SELL Kayess Mobile dental x-ray unit with Coolidge tube, \$100. Jattenborg Colonie Mobile irrigator, \$50. Joseph Dolgos, 15 Hayes St., Norwich, N. Y.

TELEPLEXES, instructographs, omnigraphs, meters, vibroplexes bought, sold, traded. Ryan Radio Co., Monroe City, Mo.

QUICK sale Supreme 400B, \$15. Candler course and tapes, \$9. Teleplex oscillator tapes, \$9. W3FHM, 3612 Locust, Philadelphia.

CRYSTALS: Eidson T9 fracture resisting 40, 80, 160 meters \$1.60 postpaid. Dependable, powerful X cut. Close frequency always supplied. Fully guaranteed, accurately calibrated. Unsolicited testimonials praise their fine quality. T9 superlapped ceramic plug-in holders \$1.10 postpaid. C.O.D. orders O. K. Eidson's, Temple, Texas.

10 meter transmitter 6N7G, 6L6G, T-20 final—50 watts output cw. Commercial job on 19" rack panel. Coils plug-in. Nationally advertised parts used. Reasonably priced. For details write Superadio, 464 E. 117th St., Cleveland.

QSL'S—Special introductory offer extended. Radio Headquarters, Ft. Wayne, Ind.

SELL Esco dynamotor 12 volt primary 500 volt 40 watt secondary, \$35. Also transmitting condensers, transformers, vibroplex, etc.; cheap. Write for details. Burt Middaugh, 8205 Michigan Ave., Chicago.

FOR Sale—pair of 204A's good condition, 242A's \$4.25 each. R. Kewley, Oconomowoc, Wis.

CRYSTALS: Special AT-cut 160-80m and holder, \$2.40. X-cut 80m, \$1.10, 40m, \$1.40. Low Drift AT-V cuts 160-80m, \$1.60, 40m, \$2. Round molded bakelite socket plug-in holders, 90¢; dozen, \$7.20. Money-back guarantee. C.O.D.'s accepted. Star Crystal Co., 1324-A Georgia, Kansas City, Kansas.

CRYSTALS: 1" square X cut 80-160 meters, \$1.40, mounted \$2.25, 40 meters, \$2.50, mounted, \$3.25. Within 3 k.c. of desired frequency. Guaranteed the very best. The Ransom Lab., N. Syracuse, N. Y.

NEW 200 watt c.w. xmitter in steel cabinet. Reasonable. Box 182, Winnebago, Ill.

CRYSTALS: Large stock Eidson's T9, X cut, accurately calibrated, 40 and 80 meter crystals, \$1.60. Super-lapped T9 ceramic plug-in holders, \$1.10 postpaid. Hieronymus Radio, 88-34 209 St., Queens Village, N. Y. C.O.D.'s O. K.

WESTON meters, laboratory used, Model 301; 100-150-200-250-300 Mills \$3.75. Model 506; 25-50-100-300 Mills \$3. Few new ones model 301; 150-250 Mills \$4.50. Model 506 100-300 Mills \$3.50. Model 476 AC Voltmeter 0-25 \$3.75. 0-1 1/2 Thermo couple \$5. Model 375 Galvanometer 30-0-30 \$5. Duplicator filter 1 Mfd. 2000 working, \$1.25. Condenser Corp. 1 Mfd. 3500 working \$1.50. RCA 50 wattier sockets 50¢. G. R. 50 Mmf. double spaced variable 75¢. National 350 Mmf. double spaced \$1.50. All good, positively guaranteed. Cash or deposit. D. C. Akers, W2FL, 181 Greenwood Ave., E. Orange, N. J.

AGSX—Very slightly used, works perfectly, relay mounting. 1500 to 20,000 k.c. coils, power supply and tubes—\$85 cash. D. C. Akers, W2FL, 181 Greenwood Ave., E. Orange, N. J.

PLATE transformers—2 1/2 KVA Hilet, 160 lb., \$39. Unmounted, \$24.50. Two year guarantee, trades considered. Send for bulletin. Leitch, Park Drive, W. Orange, N. J.

CRYSTALS: Mounted in beautiful bakelite holders, GR plugs. Within five kilocycles. 160-80m V, \$3.75. 80m X, \$2.75. Catalog. Ham Crystals, 1104 Lincoln Place, Brooklyn, N. Y.

QSL'S—Samples, W8LQM, 1040 Kelton Ave., Columbus, Ohio.

CRYSTALS mounted in round bakelite plug-in (socket) holder. X-cut 160-80m \$1.75, 40m \$2. Low drift, near zero, 160-80m \$2.50, 40m \$2.75. Wall card free. Unconditional guarantee. Post card C.O.D.'s O. K. Premium Crystal Co., Box 2250-D, Kansas City, Mo.

RMB-69's and **DB20's** in stock. W8ANT.

NEW skyriders. W8ANT.

EIMAC tubes in stock. W8ANT.

USED Breting 12. W8ANT.

USED NC100X. W8ANT.

USED FB7's. W8ANT.

USED FB7 coils. W8ANT.

USED Cardwells. W8ANT.

USED 852's. W8ANT.

WRITE for list. W8ANT.

ALL lines of new and used amateur equipment for sale. Parts bought, sold and exchanged. Write to Southern Ohio's only amateur owned amateur business, Jos. N. Davies, W8ANT, 2767 N. Bend Rd., Sta. A, Cincinnati, Ohio.

SELL, One each only, volumes II, III, and IV. Riders Perpetual Trouble Shooters Manuals, new condition, 25% off, all for \$15. W. D. Wakeman, Walton, N. Y.

CLASS B transformers \$4.25 pair and up. Modulators units, transmitters, and public address equipment. Write Radio, 112 S. Main, Blackwell, Okla.

QSL'S, Better designs; better stock; better workmanship. Free samples to Hams only. W2FJE, 143 DeKalb Ave., Brooklyn, N. Y.

QSL'S, Best on market. Samples. W2AEY.

HAMSTAMPS—add the warmth of a handshake to your QSL's.

HAMSTAMPS—Photo reproductions postage stamp size of you—your rig, etc.

HAMSTAMPS—Are reasonable—100 stamps gummed and perforated from your favorite snapshot—\$1. Negative unnecessary.

HAMSTAMPS—1730 E. 17th St., Brooklyn, N. Y.

WANTED: HRO coils, W9ERU.

ALUMINUM call letter plates 1/2" x 2" x 6 1/2", \$1. Two—\$1.50. W8ESN.

SWL'S, QSL's, attractive, reasonable. Samples. (Stamps) W8ESN, 1827 Cone, Toledo, Ohio.

COLLINS FX B brand new, entirely complete including 20 and 160 meter coils; crystal microphone; tubes; control box, etc., \$250. W2EVI.

LEARN CODE

the way you'll be using it— by SOUND



PROBABLY the best way to learn to read code is by listening to code. Probably the best way to learn to send code is by hearing your own sending repeated back to you. With the Master Telex Code Teaching Machine you learn code the natural, easy, fascinating way. Only instrument ever produced which records your sending then SENDS BACK your own key work at any speed you desire. We furnish complete course, lend you the New All Electric Master Telex, give you personal instruction with a **MONEY BACK GUARANTEE**—all at a surprisingly low cost per month. Write today for

FREE catalog Q. 4. No obligation.

"HAM" SPECIAL Standard Telex — A highly efficient code teacher using heavy specially prepared waxed paper tape, having two rows of perforations. Write for Free folder Q. 4.

We are the originators of this type instrument

TELEPLEX CO. 72-76 CORTLAND ST. NEW YORK, N. Y.

RADIO COURSES

RADIO OPERATING: Prepare for Gov't License Exam. ●
RADIO SERVICING: Including Short Wave ● **AMATEUR CODE ● ELECTRONICS ● TELEVISION** ●

Day and Evening classes—Booklet upon Request

NEW YORK YMCA SCHOOLS

4 West 63rd Street, New York City

SPECIAL TO AMATEURS

Piezo-Electric Crystals — \$2.50 EACH POSTPAID

Until supply is exhausted . . . we offer small 80 meter band crystals unmounted; accurate calibration, excellent oscillators. Limited quantity.

SCIENTIFIC RADIO SERVICE

"The Crystal Specialists Since 1925." University Park, Hyattsville, Md.

Bound Volume XX of QST

We have a limited number of Bound Volume XX of QST. This volume is made up in two sections, each containing six issues of 1936 QST. Handsomely bound and gold imprinted the complete volume is priced at \$5.00, postpaid.

Your Nearest Dealer Is Your Best Friend

Your nearest dealer is entitled to your patronage. You can trust him. He is equipped with a knowledge and understanding of amateur radio. He is your logical and safe source of advice and counsel on what equipment you should buy. His stock is complete. He can supply your needs without delay. His prices are fair and consistent with the high quality of the goods he carries. He is responsible to you and interested in you.

Patronize the dealer nearest you—You can have confidence in him

<p>ALLENTOWN, PENNSYLVANIA Radio Electric Service Co. 1024 Hamilton Street Complete stocks transmitting equipment</p>	<p>PHILADELPHIA, PENNSYLVANIA</p> <p>Eugene G. Wile 10 S. Tenth Street Complete Stock of Quality Merchandise</p>
<p>BALTIMORE, MARYLAND Radio Electric Service Co. 3 N. Howard St. Everything for the amateur</p>	<p>PROVIDENCE, RHODE ISLAND W. H. Edwards Co. 32 Broadway National, Taylor Tubes, Hallicrafters. Complete amateur supply house</p>
<p>BUFFALO, NEW YORK Radio Equipment Corp. 326 Elm Street W80BK — Ham, service and sound equipment — W80LB</p>	<p>PROVIDENCE, RHODE ISLAND Kraus & Company 89 Broadway Everything for the amateur and serviceman</p>
<p>BUFFALO, NEW YORK Dymac Radio 216 E. Genesee Street Complete Line Ham and BCL Equipment Cl. 2080</p>	<p>RICHMOND, VIRGINIA The Arnold Company 527 W. Broad Street W3EHL—"The Virginia Ham Headquarters"—W3FBL</p>
<p>MONTREAL, CANADA Canadian Elec. Supply Co., Ltd. 285 Craig St., W. Quality parts and equipment for discriminating buyers</p>	<p>ROCHESTER, NEW YORK Radio Service Shop 244 Clinton Avenue, North Complete stock amateur-BCL parts. Standard discounts. W8NUC</p>
<p>NEW YORK, N. Y. Gross Radio, Inc. 51 Vesey Street Fair dealings plus fair prices. Anything in radio</p>	<p>SYRACUSE, NEW YORK Roy C. Stage, W8IGF Complete stock of standard Ham & BCL parts Standard Discounts. Free technical service</p>
<p>PHILADELPHIA, PENNSYLVANIA Consolidated Radio Corp. 612 Arch Street Ham receivers, Transmitting tubes, Collins transmitters, etc.</p>	<p>SPRINGFIELD, MASS. S. S. Kresge Company 1540 Main Street Standard discounts on standard lines. Advisory service: W1JQ, W1FOF</p>
<p>PHILADELPHIA, PENNSYLVANIA Radio Electric Service Co., Inc. N. E. Cor. Seventh & Arch Sts. All nationally-advertised lines in stock</p>	<p>WHEELING, WEST VIRGINIA Cameradio Company 30 Twelfth Street Complete stock of amateur Equipment at standard discounts</p>
<p>PITTSBURGH, PENNSYLVANIA Cameradio Company 601-3 Grant Street "Ham" Headquarters for Pennsylvania-Ohio-W. Virginia</p>	

You Are Protected When You Buy From QST Advertisers

“Advertising for QST is accepted only from firms who, in the publisher’s opinion, are of established integrity and whose products secure the approval of the technical staff of the American Radio Relay League.”

Quoted from QST’s advertising rate card.

Every conceivable need of a radio amateur can be supplied by the advertisers in QST. And you will know the product has the approval of the League’s technical staff.

For Your Convenience

QST'S INDEX TO ADVERTISERS IN THIS ISSUE

Aerovox Corporation	88
Amperex Electronic Products	91
Astatic Microphone Laboratory	92
Barker & Williamson	94
Bassett Research Corporation	70
Birnbach Radio Company	90
Bliley Electric Company	68
Bruno Laboratories, Inc.	118
Brush Development Company	102
Burgess Battery Company	87
Burton-Rogers Company	111
Candler System Company	80
Capitol Radio Engineering Institute	98
Cardwell Mfg. Corporation, Allen D.	95
Central Sporting Goods Company	73
Clough-Brengle Company	84
Cohen's Sons, Ltd., I. S.	113
Collins Radio Company	Cov. 2
Cornell-Dubilier Corporation	86
Delaware Radio Sales Company	109
Dodge's Institute	114
Eitel-McCullough, Ltd.	85
Electrical Products Company, Inc.	110
Freck Radio & Supply Company	109
Gardiner-Levering Company	76
General Electric Company	119
General Transformer Corporation	90
Gross Radio, Inc.	127
Gulf Radio School	110
Hallcrafters, Inc., The	1, 2, 82, 118
Hammarlund Manufacturing Company	4
Harvey Radio Company	108
Harvey Radio Laboratories, Inc.	115
Heintz & Kaufman, Ltd.	103
Henry Radio Shop	92
Hipower Crystal Company	114
Instructograph Company	106
International Resistance Company	69
Johnson Company, E. F.	76
Kenyon Transformer Company	103
Leeds	97
Massachusetts Radio School	106
McElroy, T. R.	114
McGraw-Hill Book Company	72
M & H Sporting Goods Company	112
Mims Radio Company	106
National Carbon Company	115
National Company	Cov. 3, 67, 111
Newark Electric Company	99
New York V. M. C. A. Schools	124
Ohmite Mfg. Company	78
Omaha Crystal Laboratories	119
Port Arthur College	119
Precision-Piezo Service	110
Radio Mfg. Engineers, Inc.	75
Radio Supply Company	109
Radio Transceiver Laboratories	107
RCA Institutes, Inc.	102
RCA Manufacturing Company	Cov. 4, 81
Scientific Radio Service	124
Shure Brothers	82, 88
Sickles Company, F. W.	119
Signal Electric Manufacturing Co.	94
Simpson Electric Company	117
Speer Carbon Company	6
Sprague Products Company	116
Standard Transformer Corporation	78
Sun Radio Company	113
Sundt Engineering Company	114
Taylor Tubes, Inc.	77
Teleplex Company	124
Terminal Radio Corporation	117
Thordarson Electric Mfg. Company	89
Transmitter Equipment Mfg. Company	71
Triplet Electrical Instrument Co.	7
Turner Company	96
United Electronics Company	107
United Transformer Company	74, 128
Universal Microphone Company	110
Universal Signal Appliance Company	96
Utah Radio Products Corporation	93
Valpey Crystals, The	116
Vibroplex Company	106
Ward Leonard Electric Company	86
Wilson, Willard S.	109
Wincharger Corporation	102

Now! VALUE BEYOND COMPARE

DOWN TO 10 METERS

GROSS PRESENTS THE CP-55

COMPARE
and
CHECK THESE FEATURES

- Full 95 Watts input
- Ten Meter Operation
- New Taylor T20 tubes
- For operation on 10-20-40-80-160 meters
- Built-in power supply
- 3 stages, 42 Osc, 6L6 buffer, 2-T20's in final

Kit \$42.⁷⁰ Less tubes, meters, crystal — One set coils included in price

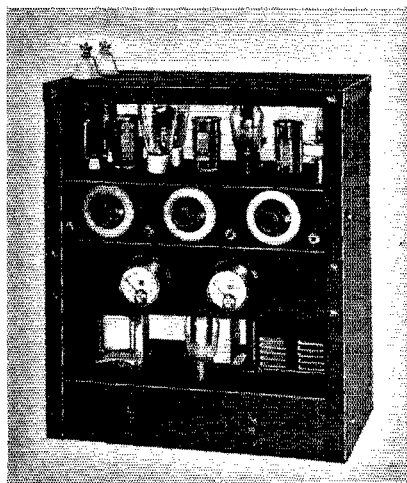

The "CP-55" uses the marvelous new T-20's in the output stage. These real transmitting tubes will give outputs and performance not possible with ordinary receiving tubes — their price is very low.

The ideal unit for the beginner or the "Old Timer" desiring an additional Transmitter for operation on 10 meters, or any other band. In the CP-55 you have available an Xmitter having real power at a ridiculously low price.

Compare the construction of the "CP-55" with units selling at many times its price. Only finest components are used such as Cardwell Condensers, Steatite Sockets, IRC Resistors, Cornell Dubilier and Aerovox Condensers, etc.

The addition of a modulator unit which is available converts the CP-55 into a fine Radiophone Transmitter.

"CW-55" RF Unit only as used in the CP-55 including one set coils, less tubes, xtal, meters..... \$18.95
Two full size surface type meters.... 7.00
Coils per set, any amateur band listed in features..... 2.85
Kit of Matched tubes for RF Unit... 6.60
One 83 Tube for power supply..... .65

"CB-55"

The Radiophone version of the "CP-55" — Also sensationally low priced

All Bands Including 10 Meters
Bulletin gives Details

NEW! "THE STANDBY" (2 TO 2000 METERS) 3-TUBE A.C. AND D.C. RECEIVER

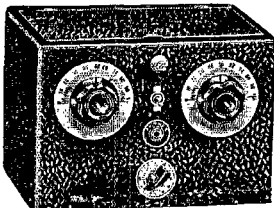

This excellent 2 to 2000 meter receiver is offered with full realization of the present-day need of the amateur for a dependable "standby" receiver which will cover practically all of the radio bands in use today. Super regeneration, which is the most efficient form of detection at these frequencies, is used from 2 to 15 meters. The R.F. stage is effectively used over the entire tuning range. Throughout the entire tuning range, there are no skips or dead spots. Loud speaker volume is available from practically every station received.

- 1000 to 1 tuning ratio ● Super regeneration below 15 meters
- Automatic change over from straight to super regeneration
- Power supply incorporated
- Individual antenna tuning for high and low wave ranges
- 1-6J5G detector, 1-6J7 R.F. stage, 1-12A7 audio amp. and rectifier.

Complete kit of parts, less coils, tubes, cab. \$7.59
2-5-10-meter coils (set of 3)..... .95
9½ to 15 meter coil..... .39
15-200 meter coils (set of 4)..... .95
200-310 meter coil .39
310-550 meter coil .39
550-1050 meter coil .60
1000-2000 meter coil..... .60
Metal cabinet.... 1.50
Kit of three tubes 2.40
Wired and tested in our lab., add. 2.00

WRITE IN FOR FREE NEW CATALOG ON HAM AND P. A. EQUIPMENT

20% DEPOSIT WITH ALL C. O. D. ORDERS

REMIT BY M. O. INCLUDE POSTAGE

Cable Address: GROSSINC

GROSS RADIO, INC., 51 VESEY STREET, NEW YORK CITY

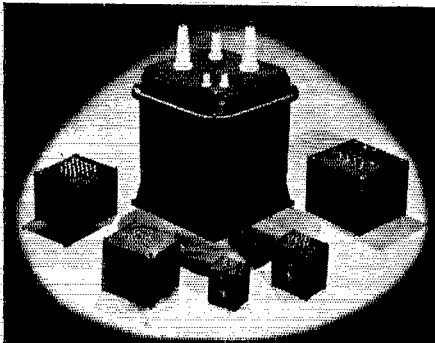

HIGH FIDELITY

Many amateurs pride themselves upon rigs as good as a broadcast station's. To these people we can earnestly recommend our Linear Standard grade of units. These transformers are individually tested and guaranteed to be ± 1 DB from 30 to 20,000 cycles. Low level input units are now available with a *tri alloy magnetic filter* which encloses a hum-balanced coil structure. These refinements together with a special grade of high permeability cast case make possible an audio unit having the lowest hum pickup of any available commercially.

LS-10	*Line to single grid.....	\$ 9.00
LS-12	*Line to push pull grids.....	12.00
LS-21	1 plate to 2 grids.....	7.80
LS-50	Triode plate to *Line.....	9.00

*500, 333, 250, 200, 125, 50 ohms impedances available.

MEDIUM PRICE

The UTC PA grade of transformers comprises a group of high quality transformers at unusually reasonable prices. A very complete line of units are available to cover every PA and amateur requirement. These transformers are uniform in appearance, universal mounting, and finished in attractive eggshell black. Low level transformers incorporate a hum bucking coil structure for low pickup.

PA-132	1 Plate to 2 Grids.....	\$3.00
PA-2L6	30 Watts, 6L6's to line and voice coil.....	6.00
PA-4L6	60 Watts, 6L6's to line and voice coil.....	9.00
PA-233	Driver to 2A3's, 6L6's, etc.....	3.60
PA-428	Power transformer for 6L6's.....	8.40

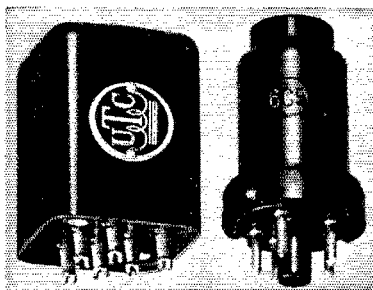
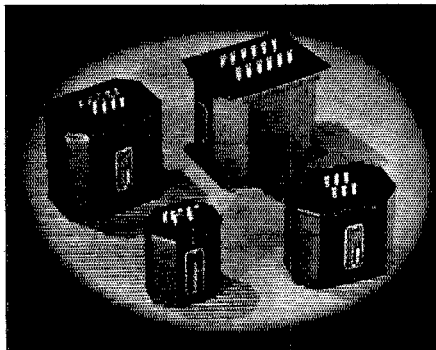

PORTABILITY

Where size and weight are important factors UTC ultra compact audio units are ideal. The frequency response is ± 2 DB from 30 to 20,000 cycles. The size is $1\frac{7}{16} \times 1\frac{7}{16} \times 1\frac{1}{2}$ and the weight is only $5\frac{1}{2}$ ounces. A full hum balancing coil structure is used to effect minimum hum pickup.

A-10	*Line to single grid.....	\$6.00
A-12	*Line to push pull grids.....	6.00
A-24	1 plate to *Line.....	6.00
A-30	300 Hy audio choke.....	4.20

*500, 333, 250, 200, 125, 50 ohms impedances available.

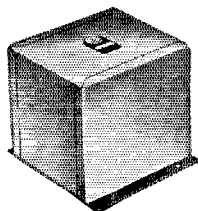
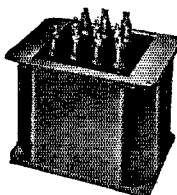

VARIMATCH

All UTC transformers are designed for maximum flexibility. The Varimatch series are noteworthy in this respect as they will match any audio tubes to any RF tubes within their power ratings, eliminating the possibility of obsolescence as new tubes are announced.

VM-1	30 watts audio to RF load	\$ 4.80
VM-2	60 watts audio to RF load	7.50
VM-3	120 watts audio to RF load	12.00
VM-4	300 watts audio to RF load	19.50
VM-5	600 watts audio to RF load	42.50

Varimatch input transformers match all driver tubes to all class B output tubes. Net prices vary from \$3.00 to \$12.00.

LOW PRICE

Where price is a paramount factor but where good units are desired the UTC Chromshield audios are suggested. Units of this line represent the greatest value in their price range and are finished in attractive chromium plate with bottom lead construction.

CS-1	Single plate to grid.....	\$1.41
CS-2W	Single plate to 2 grids 1:1 ratio.....	2.10
CS-5	Single or DB mike to 1 grid.....	1.50
CS-30	46 plate to 2-46 grids.....	1.65
CS-35	6B5's to 5000, 3500 ohms..	2.25
CS-41	10 Hy-150 MA, 95 ohms..	1.80

All prices shown are net to amateurs

UNITED TRANSFORMER CORP.

72 SPRING STREET

NEW YORK, N. Y.

EXPORT DIVISION: 100 VARICK STREET NEW YORK, N. Y. CABLES: "ARLAB"

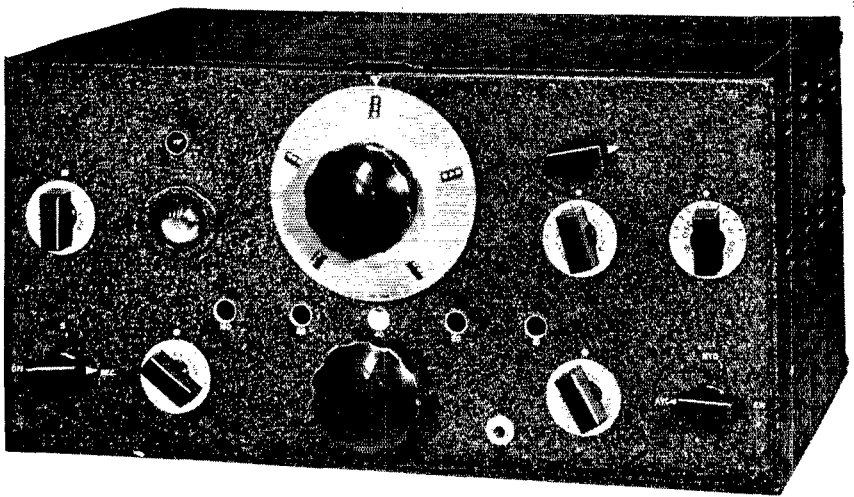

FOR AMATEURS:

The NEW NC-101X

The new NC-101X is strictly an amateur receiver, combining the more popular features of the HRO and the NC-100. Like the HRO it provides extreme electrical bandspread, with each of the amateur bands padded to span a uniform 400 dial divisions. Like the NC-100, it employs the Movable Coil Tuning Unit which makes plug-in coils as rapid and convenient as a coil switch, without sacrifice of electrical efficiency.

The general chassis design is similar to that of the NC-100. Details include variable band width crystal filter*, built-in power supply, CW oscillator, micrometer dial, amplified and delayed AVC, tone control, B-supply switch, AF and RF gain controls and tuning indicator. Coils cover the amateur bands only (10, 20, 40, 80, and 160 meters). Net Price, Type NC-101X Receiver, including power supply, tubes, speaker, and crystal filter*, \$129.00.

* U. S. Patent 2,054,757

*Now at your dealers
Battery model now also available*

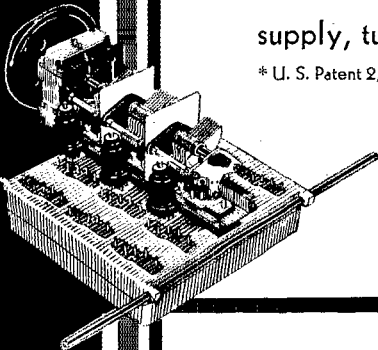

NATIONAL COMPANY, INC., MALDEN, MASS.

NOW there is no
need to build your own when
the **NEW ACT-20** costs so little

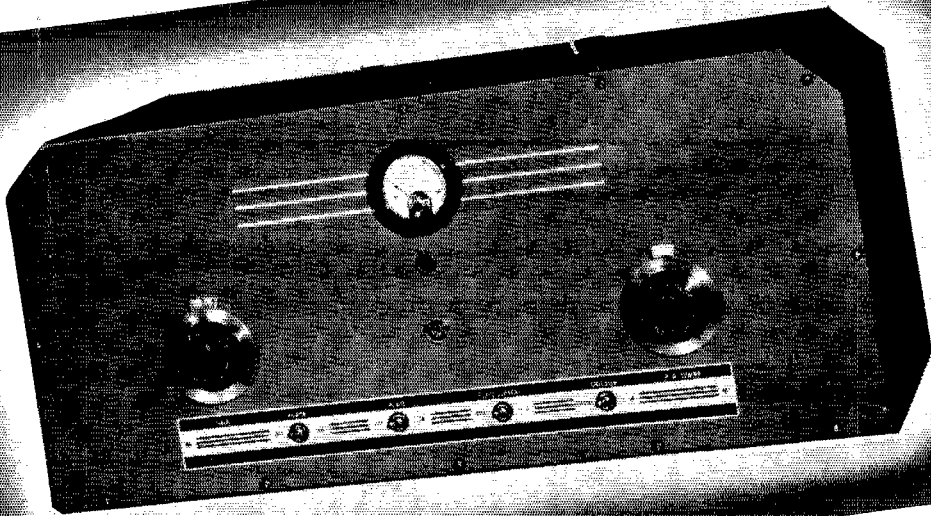

\$129.50

Amateur's net price
f.o.b. factory

THE flexibility of 5-band operation, a minimum of adjustments, and reliable performance make the ACT-20 an ideal choice of low-powered transmitters. Amateur's net \$129.50, with one set of coils but less accessories.

The ACT-20 offers you the assured performance of factory-built equipment at modest cost. Extensive pre-production field tests of the ACT-20 were made to obtain complete assurance of its performance capabilities. Particular emphasis was placed on 30 megacycle performance, and the tests indicate that world-wide communication is possible under favorable

conditions. In a single week-end every U. S. district was worked on 7 megacycle C. W. and coast-to-coast QSO's were had on 14 megacycle phone.

The nominal power output of the ACT-20 is 20 watts for C.W. and 16 watts for 100% modulated phone. Easily installed, quickly adjusted and reliable in performance, the ACT-20 may be shifted from band-to-band with a minimum of adjustments. For other outstanding features see your supplier or write for folder. A copy of the operating instructions will be sent upon receipt of 25¢ in stamps to cover handling and postage.



for Amateur Radio

RCA MANUFACTURING CO., INC.

CAMDEN, N. J. • A SERVICE OF THE RADIO CORPORATION OF AMERICA