

RCA VICTOR
TELEVISION SERVICE CLINIC

THE 800 SERIES

COLOR TELEVISION RECEIVERS
CTC7 CHASSIS

TECHNICAL FEATURES — SET-UP — ANTENNAS

PREPARED BY COMMERCIAL SERVICE
RCA SERVICE COMPANY, INC., CAMDEN 8, N. J.

A Service of Radio Corporation of America

THE RCA VICTOR TELEVISION SERVICE CLINIC

The RCA Victor Television Service Clinic is a means by which all service technicians can keep abreast of the ever increasing field of television servicing.

The success of our Clinic Program is attributed to the meeting of a demand for comprehensive coverage of television service and installation practices. This demand has been met through the presentation of a series of Service Clinic Lectures, beginning with basic television principles, progressing through UHF, and continuing with the latest developments in color television.

The first nine lecture booklets have been compiled in Volume I—Television Service Clinic Lectures. The volume includes the following titles:

- No. 1: *Basic Circuit Description of an RCA Victor Television Receiver.*
- No. 2: *Servicing the RCA Victor Television Receiver—The R-F Unit, Picture I-F and Sound Channel.*
- No. 3: *Servicing the RCA Victor Television Receiver—The Video and Sync Circuits.*
- No. 4: *Servicing the RCA Victor Television Receiver—Deflection Circuits and Power Supplies.*
- No. 5: *Servicing the RCA Victor Television Receiver—Troubles Other Than Component Failures.*
- No. 6: *Practical Antenna and Transmission Line Considerations and RCA Victor Television Receiver Installation Techniques.*
- No. 7: *Technical Features of the New RCA Victor "Million Proof" Television Chassis.*
- No. 8: *Technical Features of the RCA Victor KCS66-68 Intercarrier-Sound Television Chassis.*
- No. 9: *Introduction to UHF Television.*

The lectures listed below are printed in individual booklet form.

- No. 10: *Technical Features and Simplified Alignment of the RCA Victor KCS72-72A Television Chassis.*
- No. 11: *Technical Aspects of RCA Victor UHF Receiving Equipment.*
- No. 12: *Principles of Color Television and Technical Features of the RCA Victor Model CT-100 Color Television Receiver.*
- No. 13: *Technical Features of the RCA Victor Model 21CT55 Color Television Receiver.*
- No. 14: *Technical Features of the RCA Victor KCS93 Television Chassis.*
- No. 15: *Technical Features of the RCA Victor Model 21CT662U Color Television Receiver.*
- No. 16: *Servicing Color Television Receivers — The 21CT660U Series.*
- No. 17: *The 700 Series Color Television Receivers — Technical Features — Set-up — Servicing.*

The Volume and current Clinic Lectures are available, at a nominal charge, from RCA Service Company, Inc., Commercial Service, Camden 8, N. J.

FOREWORD

The purpose of this booklet is to provide an easily understood explanation of circuit operation for the RCA Victor 800 Series color television receivers using the CTC7 chassis. It also provides practical installation and set-up information for the technician who may be required to service these receivers.

The Technical Features section of the booklet describes the features introduced in these instruments and explains the operation of the circuits and the functions of components.

The second section of the booklet illustrates and thoroughly covers installation and set-up of the receivers.

A special feature of this booklet is a section devoted to antennas and antenna installations for color television reception.

It is assumed that technicians using this publication are familiar with terms used in discussing television receivers. Those who are not familiar with color television are referred to Television Service Clinic booklets listed on the page facing and to other publications currently available from RCA Service Company, Inc.

THE TEXT OF THIS BOOKLET IS DESIGNED FOR PRESENTATION IN LECTURE FORM AT CLINIC MEETINGS SPONSORED BY THE RCA VICTOR TELEVISION DIVISION AND THEIR RCA VICTOR DISTRIBUTORS, THE SERVICE ORGANIZATIONS, AND OTHERS WHO ATTEND THESE LECTURES, HOWEVER, ARE NOT DESIGNATED AS AUTHORIZED TO RENDER TELEVISION SERVICE TO RCA VICTOR TELEVISION RECEIVERS BY MERE ATTENDANCE AT THE CLINIC MEETINGS.

TABLE OF CONTENTS

TECHNICAL FEATURES OF THE RCA VICTOR 800 SERIES COLOR TELEVISION RECEIVERS

	Page		Page
INTRODUCTION	5	VERTICAL DEFLECTION	15
VHF TUNER UNIT	8	CHROMINANCE CIRCUITS	16
UHF/VHF TUNER	8	1st Bandpass Amplifier	16
PICTURE I-F	9	2nd Bandpass Amplifier	17
SOUND I-F—AUDIO	10	Demodulators	17
VIDEO	11	Color Synchronization	18
DEFLECTION SYNCHRONIZATION	12	Automatic Chroma Control	19
Noise Inverter	12	Color Killer	19
HORIZONTAL DEFLECTION AND HIGH		HORIZONTAL BLANKING	20
VOLTAGE	13	KINESCOPE	20
Horizontal Oscillator and Control	13	Kinescope Controls	21
Horizontal Output—High Voltage	13	CONVERGENCE	22
AGC	15	LOW VOLTAGE POWER SUPPLY	23

RECEIVER SET-UP AND SERVICE

RECEIVER SET-UP CONSIDERATIONS	24	CONVERGENCE ADJUSTMENTS	32
EQUIPMENT REQUIRED	24	Center Convergence	32
CHASSIS SET-UP ADJUSTMENTS	25	Horizontal and Vertical Convergence	32
Noise Inverter	25	Vertical Convergence Adjustments	32
Height, Vertical Linearity, Vertical Centering... ..	25	Horizontal Convergence Adjustments	34
Focus	25	Final Center Convergence Adjustments	35
Horizontal Centering and Width	25	AFPC ADJUSTMENTS	36
Horizontal Drive and Efficiency Adjustments	26	Killer Detector Adjustment	37
High Voltage Adjustment	27	DEMODULATOR PHASING ADJUSTMENTS ..	37
R-F Oscillator Adjustment	28	CHASSIS REMOVAL	38
FM Trap Adjustment	28	REMOVAL OF KINESCOPE	38
KINESCOPE SET-UP ADJUSTMENTS	28	KINESCOPE INSTALLATION	38
Color Purity Adjustment	29	RECEIVER SET-UP CHECK LIST	40
Z Purity Adjustment	29	FUSE DATA	40
Edge Purity Magnet Adjustment	30		
Color Temperature Adjustment	30		

ANTENNAS

ANTENNA CONSIDERATIONS	41	ANTENNA SYSTEM ACCESSORIES	44
ANTENNA SYSTEM RESPONSE	41	Attenuator Pads	44
MULTI-PATH SIGNALS	41	Boosters	44
ANTENNA GAIN	42	Signal Distribution Systems	44
FRONT-TO-BACK RATIO	42	SUMMARY OF ANTENNA SYSTEM	
ANTENNA CHARACTERISTICS	42	CONSIDERATIONS	45

TECHNICAL FEATURES OF THE RCA VICTOR 800 SERIES COLOR TELEVISION RECEIVERS

INTRODUCTION

The 800 Series Victor Color television receivers include many features designed as conveniences for the consumer and in addition, a host of features especially as considerations for the service technician.

All of the deluxe models in the 800 Series color receivers use the new CTC7 chassis. All models are available with a VHF only tuner, or, optionally, a combination UHF/VHF head end. The UHF/VHF models have a "U" designation following the model number.

The 21CYP22 tricolor kinescope is introduced in the 800 series receivers. This new glass-envelope picture tube, employing three separate electron guns and an internal shadow mask, provides in either color or black-and-white, a high brightness picture with a viewing area of approximately 260 square inches.

The CTC7 chassis features: intercarrier FM sound system; quadrature-grid FM detector; separate picture and sound detectors; 4.5 mc. sound trap and sound rejection control in the input circuits of the video amplifier stages; AGC control of the RF amplifier and the first and second picture I-F amplifier stages; an automatic noise cancellation circuit; automatic frequency phase control in the chrominance circuits; crystal-controlled 3.58 mc. color subcarrier reference oscillator; stabilized "synchroguide" horizontal oscillator and control; an automatic chroma control circuit; an automatic noise-immune color killer circuit; and continuously regulated high voltage to the ultor of the kinescope.

Some of the customer features include improved picture brightness and contrast for both color and black-and-white pictures; and convenient, color coded, "TINT" and "COLOR" controls. These controls show, on the escutcheon, the direction of rotation for proper tuning to achieve the desired color effects on the viewing screen of the kinescope. This feature is also an aid to the service technician.

A feature of particular interest to the service technician is the mechanical arrangement of the convergence circuits. The controls necessary to perform convergence adjustments are on a printed circuit in a mounting which is detachable from the cabinet. When the convergence control panel is removed from its normal mounting position it may be inverted and secured to two mounting screws provided on the rear of the cabinet. This permits adjustment of the dynamic convergence controls from the front of the receiver.



Fig. 1—RCA Victor 800 Series Color Television Receiver—Model 21CD8865.

The CTC7 chassis contains six printed circuit boards. The printed circuit boards are designated by "PW" numbers and include the following circuits:

- PW200—Sound I-F, FM Detector—1st Audio, Audio Output, Noise Inverter.
- PW300—1st, 2nd, 3rd Picture I-F, Picture Detector, Sound Detector, Noise Inverter.
- PW400—1st Video, 2nd Video, AGC amplifier.
- PW500—Sync Output, Vertical oscillator, vertical output.
- PW600—Horizontal oscillator and control.
- PW800—Dynamic convergence controls.

The chrominance and color synchronization circuits, horizontal output and high voltage, and the low voltage power supply circuits are mounted directly on the chassis.

Following the practice established in previous receivers, components in the various circuits are identified with symbol numbers relating to the printed circuit boards on which the components are mounted. For example: R307 is the cathode resistor of the 2nd Picture I-F stage—located on printed circuit board PW300. C503 is a capacitor on printed circuit board PW500.

The low voltage power supply, high voltage components, variable resistors, and transformers mounted on the chassis proper are identified under symbol numbers bearing the "100" designation except for components in the chrominance and color synchronization circuits. These parts carry the "700" designation. Thus in most instances, by noting the symbol designation, it is easy to determine the section of the receiver to which the component is related.

The rear view of a representative model of the 800 Series color receivers, model 21CD8865, shows, in figure 2, the location of the major components.

An overall block diagram of the receiver circuits is shown in figure 3.

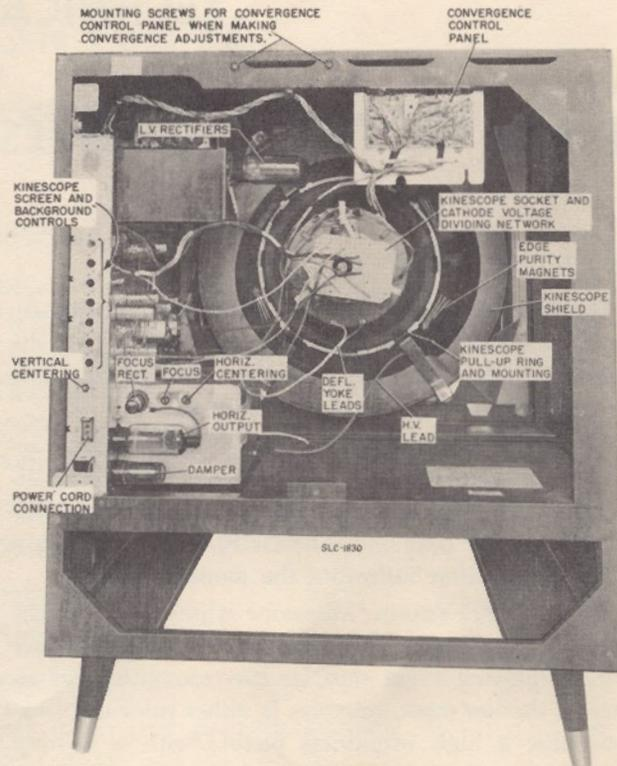

Fig. 2—Rear view of Model 21CD8865 showing major component locations.

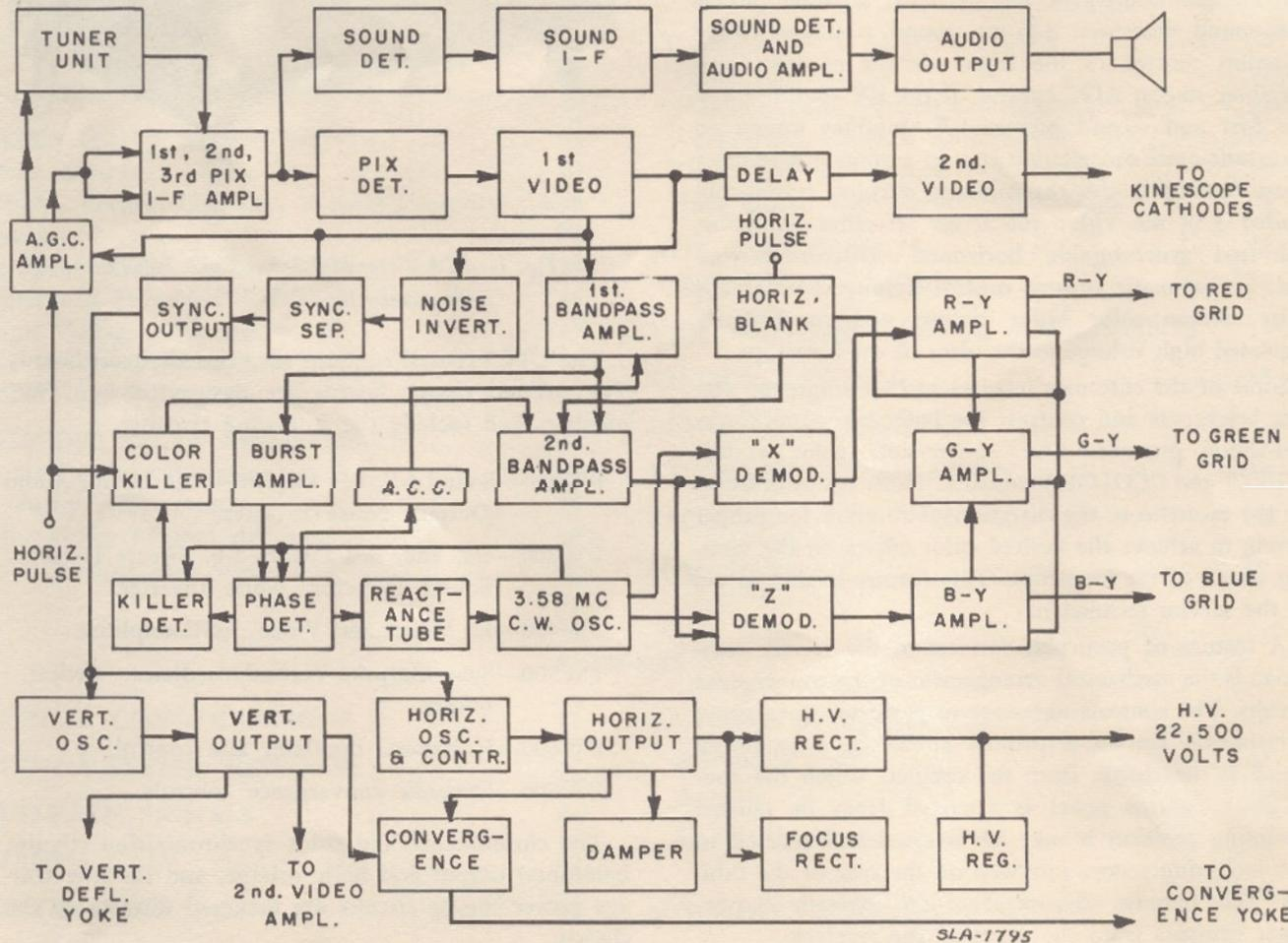

Fig. 3—Block diagram—circuits in 800 Series color television receiver.

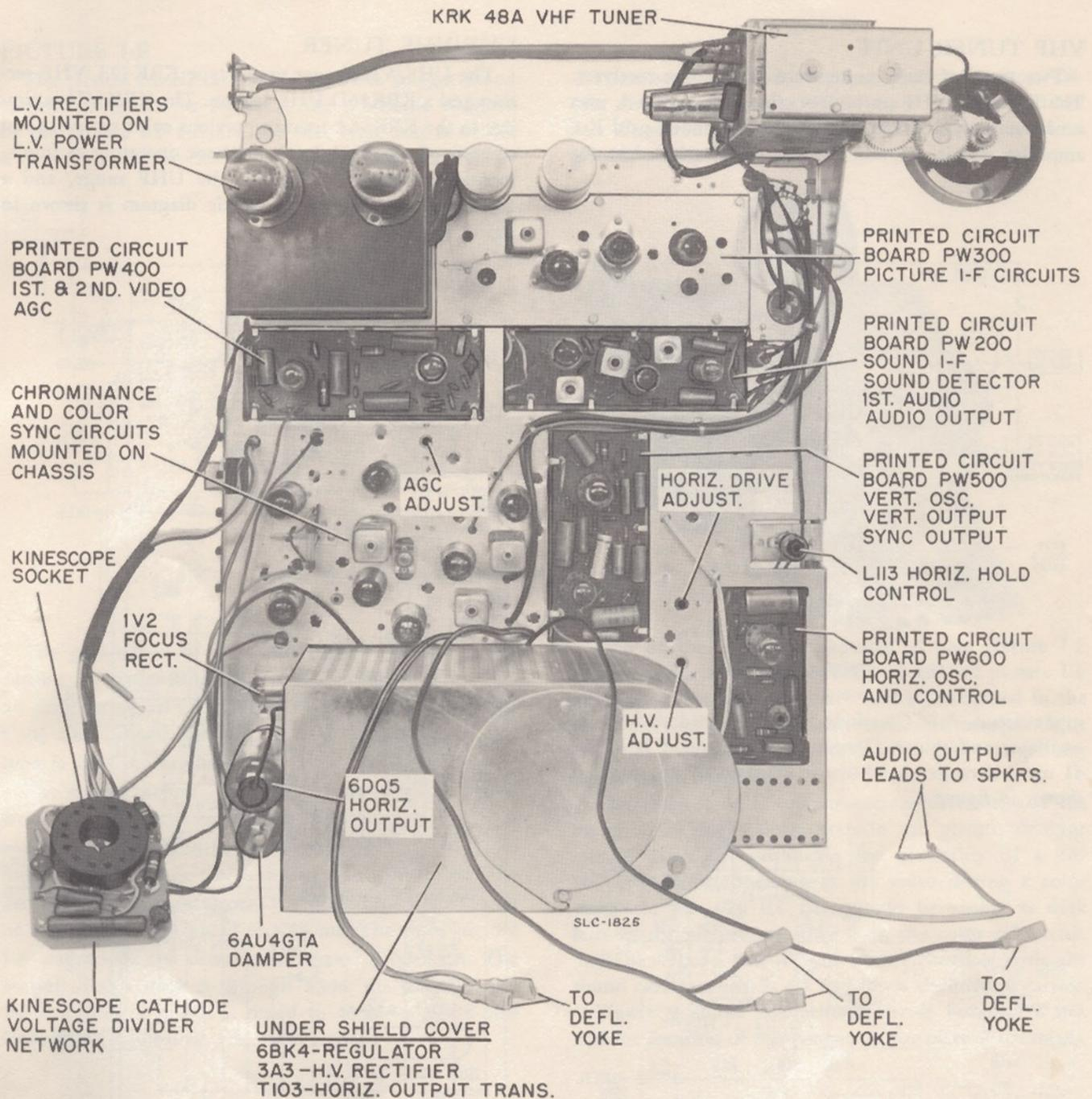

Fig. 4—CTC7 chassis removed from cabinet. Major circuits, components and function locations.

Figure 4 shows a view of the chassis in the position when removed from the cabinet for service. The locations of the printed circuit boards and other com-

ponents and controls are identified as an aid to the service technician in becoming familiar with these instruments.

VHF TUNER UNIT

Two types of tuner units are used in these receivers. The KRK48A VHF only tuner, shown in figure 5, uses a new tube, type 6BC8, in a driven grounded grid R-F amplifier circuit. I-F and FM traps are included in the

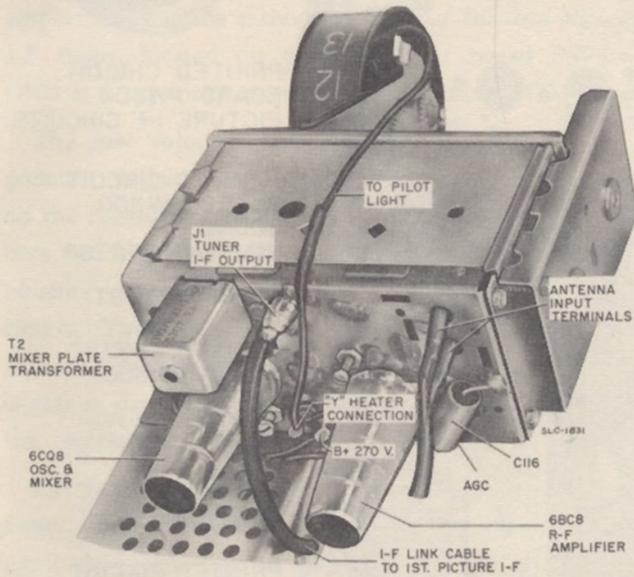

Fig. 5—KRK48A VHF tuner.

input circuit. A 6CQ8 triode-pentode is used as the local oscillator and mixer. Output from the mixer is in the 41 mc. I-F range. A schematic diagram of this tuner is shown in figure 6.

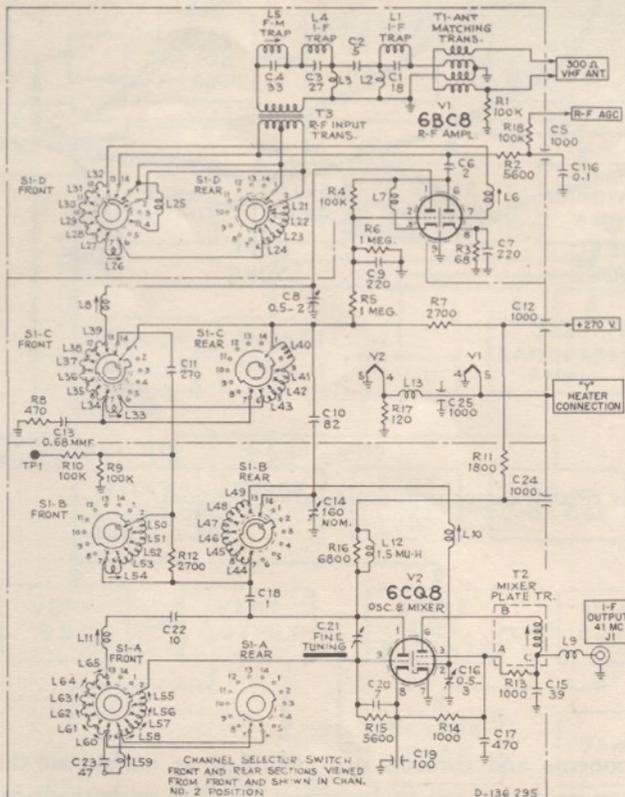

Fig. 6—Schematic diagram—KRK48A VHF tuner.

UHF/VHF TUNER

The UHF/VHF tuner uses a type KRK49A VHF section and a KRK56D UHF section. The KRK56D is similar to the KRK56A used in previous color receivers and consists of a 6AF4A local oscillator operating at fundamental frequency throughout the UHF range, and a 1N82 crystal mixer. A schematic diagram is shown in figure 7.

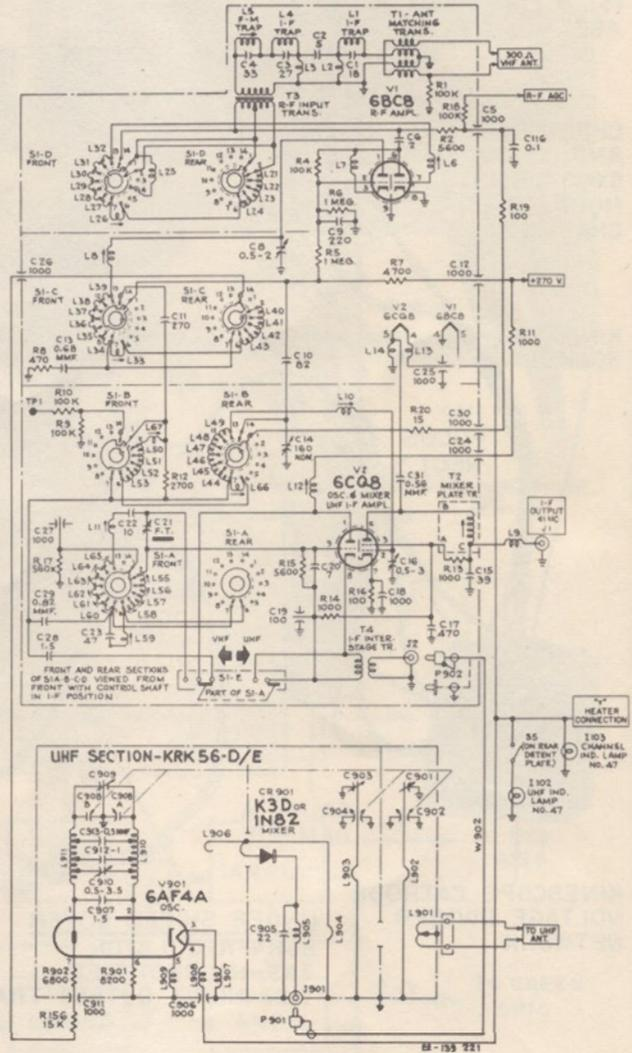

Fig. 7—Schematic diagram—KRK49A-KRK56D UHF/VHF tuner.

VHF tuning in the "U" models is accomplished with a 13 position switch type tuner. The 13th position automatically switches to a continuously variable tuning system which covers all 70 UHF channels.

The KRK49A in VHF operation uses the same tubes and operates in the same manner as the KRK48A VHF only tuners. The KRK49A however, has an extra switch position. When switched into this position the output of the KRK56 UHF unit is fed to the 6CQ8 which becomes a 41 mc. I-F amplifier for the UHF channels.

PICTURE I-F

The picture I-F circuits consist of three stagger-tuned stages. As shown in figure 8, the schematic diagram of the picture I-F circuits, the first stage uses a 6BZ6, a new type tube in RCA Victor color receivers.

These stages, plus the separate picture detector, CR-302, and sound detector, CR301; a 4.5 mc. trap, L306 and the sound rejection control, R312, are mounted on printed circuit board PW300.

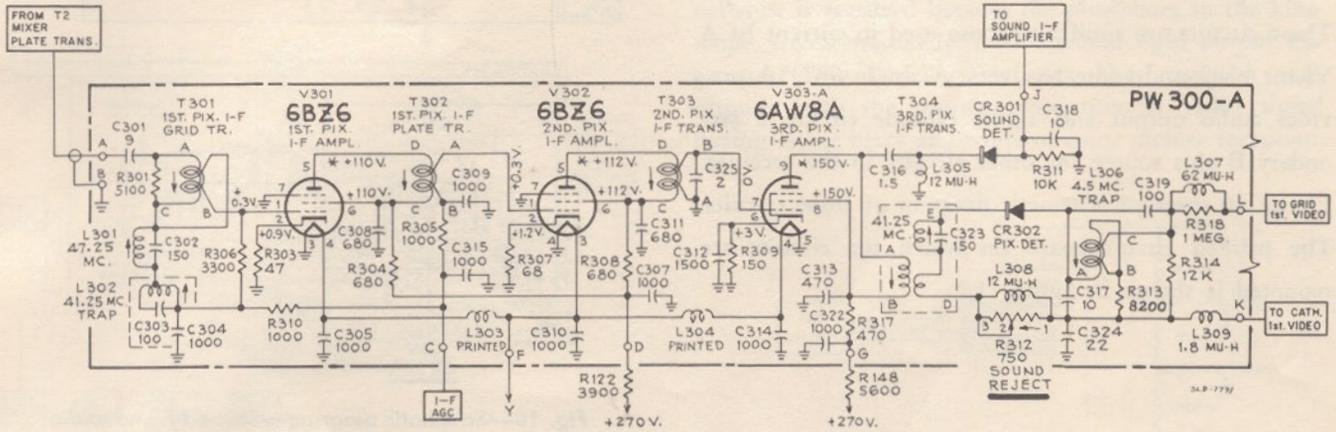

Fig. 8—Schematic diagram—picture I-F circuits—CTC7 chassis.

The grid circuit of this stage includes T301, the 1st picture I-F transformer, tuned to 44.0 mc.; L301-C302, an adjacent sound trap, tuned to 47.25 mc.; and L302-C303 a sound trap tuned to 41.25 mc. The grid of this tube is AGC controlled.

The second picture I-F stage also uses a 6BZ6. Signal from the first stage is coupled through T302, the 1st picture I-F plate transformer (tuned to 45.75 mc.), to the grid of this stage which is also AGC controlled. The 2nd picture I-F transformer, T303, is in the plate circuit of this stage and is tuned to 42.5 mc. The third picture I-F stages uses the pentode section of a 6AW8A. The output of this stage is through T304, the third picture I-F transformer which is tuned to 43.8 mc. T304 also includes an additional 41.25 mc. trap.

One of the important features of this picture I-F system is the use of the 6AW8A as the 3rd picture I-F amplifier. This tube is rather "husky" compared to the types previously used in this service. Consequently it does not overload easily and thus handles a larger signal without distortion.

The features of a separate picture detector, and the inclusion of the 4.5 mc. trap in the picture detector circuit, assist in minimizing the possibility of a 920 KC beat from appearing in the video during a color program. The 920 KC beat would be visible as dark bars in the picture resulting from the color subcarrier, 3.58 mc. above the picture carrier, beating with the sound carrier which is 4.5 mc. above the picture carrier.

Figure 9 shows the printed circuit board, PW300, and the location of components in the picture I-F stages.

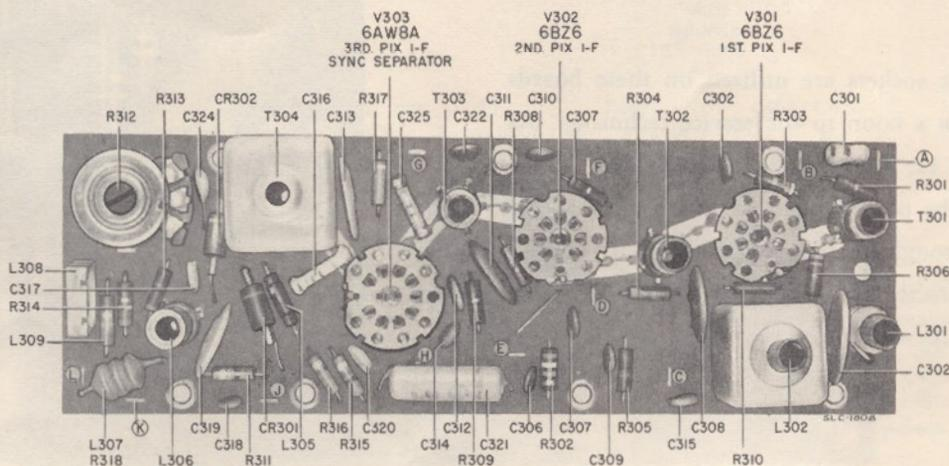

Fig. 9—Location of components on PW300—picture I-F printed circuit board.

SOUND I-F AUDIO

The sound system in these receivers differs from the circuits used in earlier models. The 800 Series receivers use a single stage of 4.5 mc. sound I-F amplification and a quadrature-grid FM detector—first audio stage. These circuits are similar to those used in current RCA Victor black-and-white receivers. A single 6AQ5A provides audio output and, in its cathode circuit, a secondary B-plus source for other circuits in the receiver. Figure 10 shows a schematic diagram of these circuits. The printed circuit board on which the circuits are mounted is shown in figure 11.

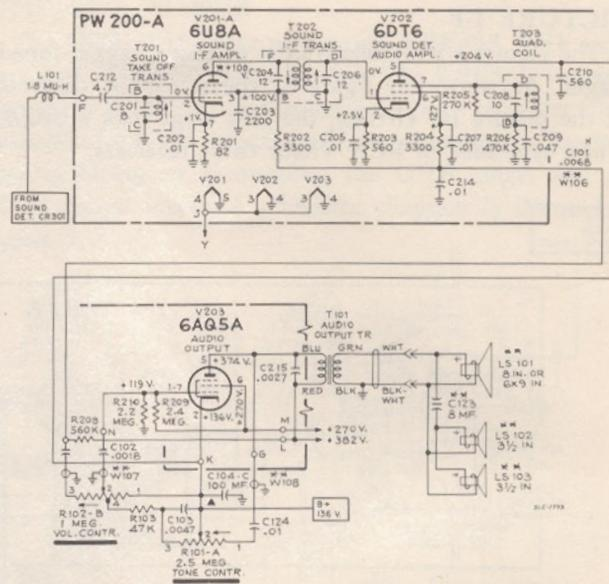

Fig. 10—Schematic diagram—Sound I-F and audio circuits—CTC7 chassis.

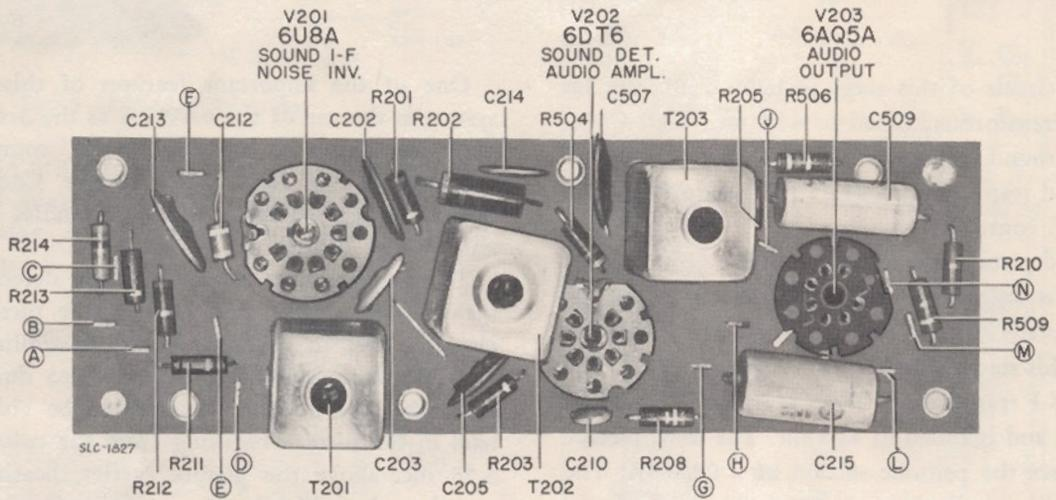

Fig. 11—Location of components on PW200—Sound I-F and audio printed circuit board.

New type tube sockets are utilized on these boards and should prove a boon to the service technician. As shown in figure 12, from the top side of the printed boards, each of the pin connections on the tube sockets are accessible through a guide opening. Thus, voltage measurements directly at the tube pins can be made quickly and easily whenever required.

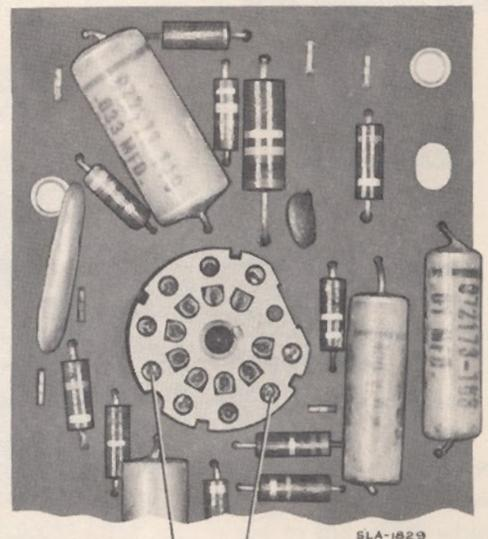

Fig. 12—Tube pin connections are accessible at tube socket.

VOLTAGES AT TUBE PINS CAN BE MEASURED FROM TOP OF CHASSIS THROUGH OPENINGS ON TUBE SOCKET.

VIDEO

Two video amplifiers are incorporated in the CTC7 chassis. The two video stages provide the luminance (brightness) information to the cathodes of the kinescope. In addition, the first video stage supplies, through the chrominance circuits, the chrominance (color) information to the grids of the kinescope.

A schematic diagram of the first and second video amplifiers is shown in figure 13.

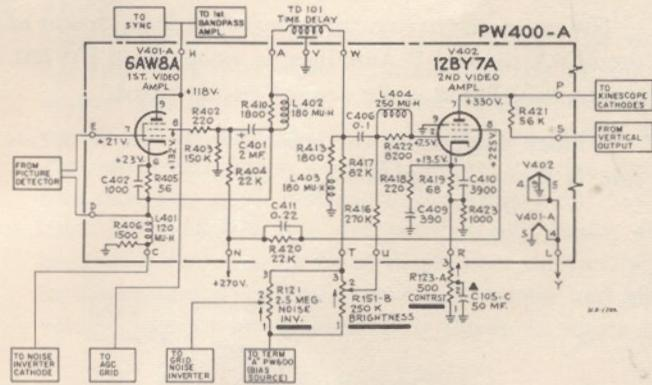

Fig. 13—Schematic diagram—1st and 2nd video amplifiers.

The first video amplifier uses the pentode section of a 6AW8A.

Video, from the picture detector, is applied between the control grid and the cathode of the 1st video amplifier.

From the cathode circuit of this stage video is fed to the grid of the 2nd video amplifier through the delay line, TD101, and to the cathode of the noise inverter.

The plate circuit of the 1st video stage supplies the chrominance signal to the grid of the 1st Bandpass amplifier, and sync and AGC information to their respective circuits as shown in the block diagram figure 14.

The second video amplifier, a 12BY7A, amplifies the luminance portion of the signal (black-and-white information.) This signal is applied to the cathodes of the kinescope through a voltage dividing network as shown in the block diagram, figure 15. The dividing

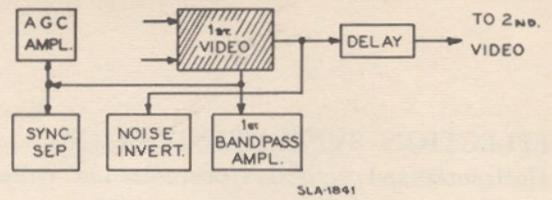

SLA-1841

Fig. 14—Block diagram—1st video amplifier—showing signal distribution.

network is required because the phosphors in the kinescope, characteristically, have unequal light output efficiencies. The dividing network thus supplies each cathode with the proper proportion of video signal during either black-and-white or color picture reception.

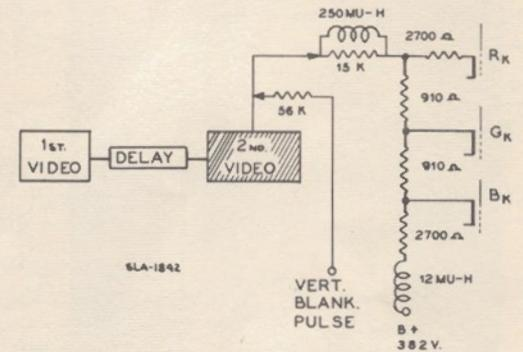

SLA-1842

Fig. 15—Block diagram—2nd video amplifier—showing output to kinescope cathodes.

Vertical retrace blanking of the picture is accomplished in the second video amplifier. This is done by applying a pulse from the plate of the vertical output stage to the plate of the second video amplifier. This positive pulse, added to the signal at that point blanks the kinescope during vertical retrace time.

Picture contrast is varied by a potentiometer in the cathode circuit of the second video stage. Brightness is controlled by a variable resistance in the grid circuit. Bias for this circuit is obtained by filtering a portion of the horizontal drive voltage in the grid circuit of the horizontal output stage. Figure 16 shows the video printed circuit board PW400, and the location of the components in the 1st and 2nd video amplifier stages.

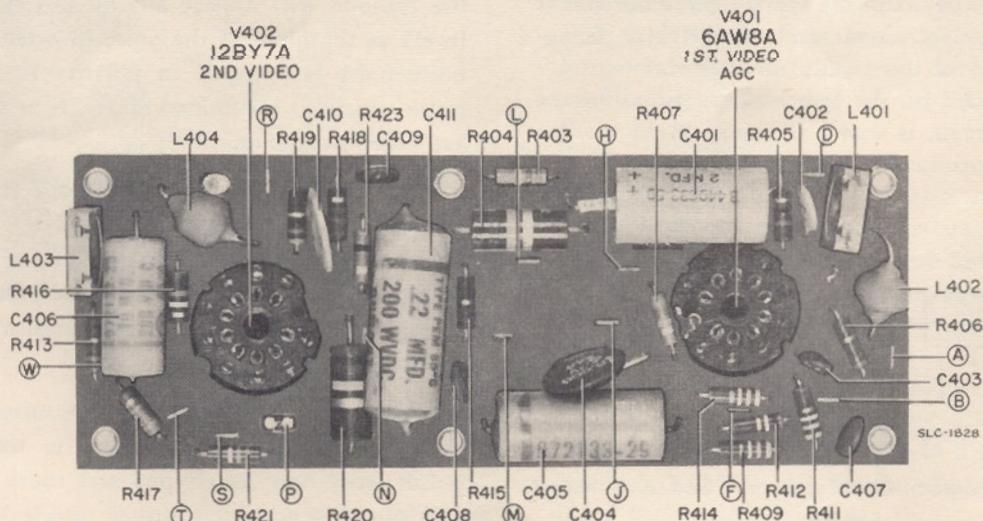

Fig. 16—Location of components in 1st and 2nd video amplifier stages—printed circuit board PW400.

HORIZONTAL DEFLECTION AND HIGH VOLTAGE

The horizontal deflection and high voltage sections of the CTC7 chassis include the horizontal oscillator and control stage, horizontal output, the damper, a high voltage rectifier, a rectifier for the kinescope focus voltage and a circuit to maintain regulation of the high voltage.

In addition to the functions of supplying high voltage and focus voltage for the kinescope, the horizontal output circuits also supply control voltages for other circuits in the receiver. These include the 2nd Video Amplifier (brightness control), noise inverter (grid bias control), AGC, horizontal blanking, burst keyer, color killer horizontal convergence, B-plus boost, and horizontal deflection. A block diagram of the functions in the horizontal oscillator, horizontal output and high voltage sections of the receiver is shown in figure 20.

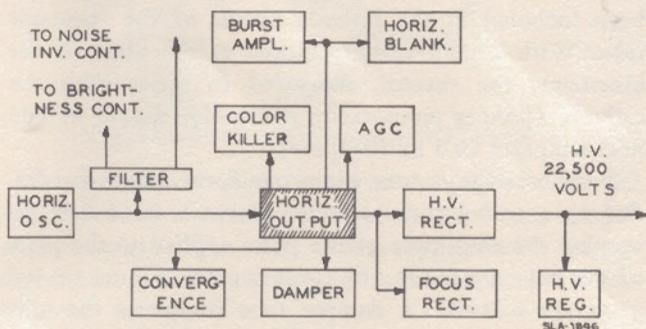

Fig. 20—Block diagram—circuits affected by the horizontal oscillator and output stages.

Horizontal Oscillator and Control

A modified "synchroguide" circuit, using a 6CG7, comprises the horizontal oscillator and control functions in the CTC7 chassis. This circuit is mounted on its own printed circuit board, PW600. A schematic diagram is shown in figure 21. The horizontal frequency control, L113, is used as the horizontal hold control.

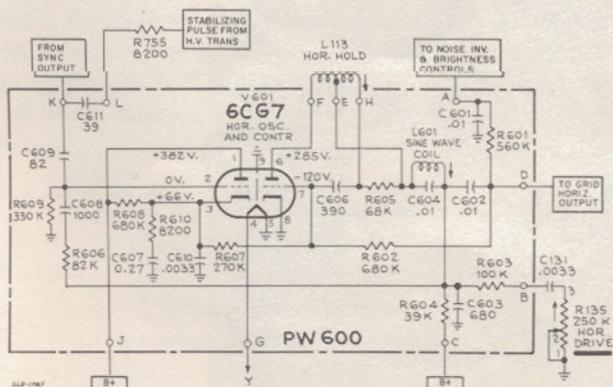

Fig. 21—Schematic diagram—horizontal oscillator and control circuits.

To further insure sync stability, a pulse from the

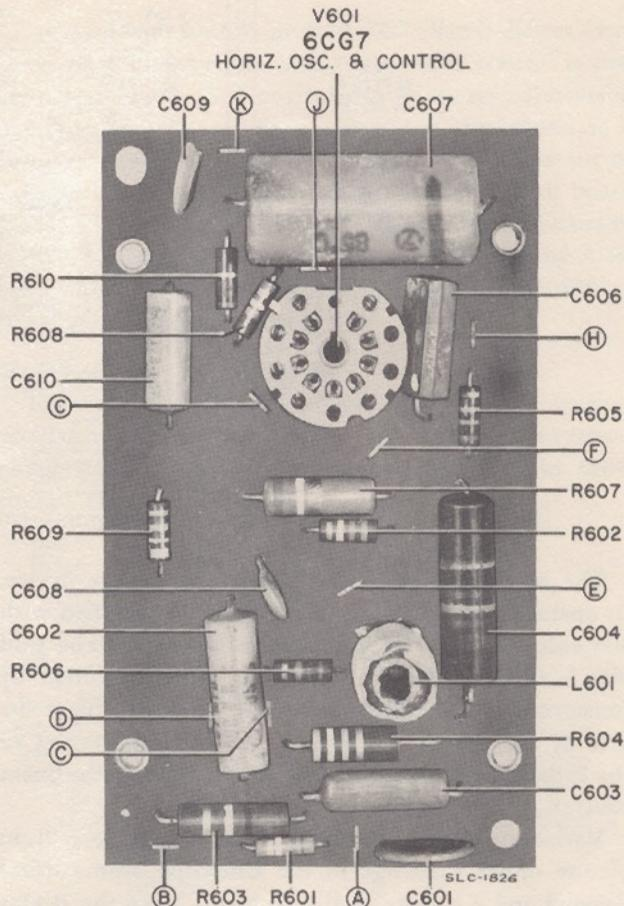

Fig. 22—Location of components in the horizontal oscillator and control circuits—printed circuit board PW600.

horizontal output transformer AGC line is coupled to the horizontal sync input.

Figure 22 shows the printed circuit board PW600, and the location of the components in the horizontal oscillator and control circuits.

Horizontal Output—High Voltage

The high voltage section is mounted on the chassis and does not use the printed circuit type of construction. A 6DQ5 horizontal output tube is driven by the horizontal oscillator. The grid circuit of the 6DQ5 is used as the supply source for the brightness control and the noise inverter control.

The horizontal output transformer, shown in the schematic diagram, figure 23, is a source of pulses for functions in the receiver other than those normally associated with high voltage and horizontal deflection. These include, AGC, horizontal retrace blanking, burst, keying the color killer, and horizontal convergence.

The 21CYP22 tricolor kinescope is operated with 22,500 volts at its ultor in the 800 series receivers. The high voltage, developed by the 6DQ5 and the high voltage transformer, is rectified by a type 3A3 and regulated to 22,500 volts by the shunt regulator circuit using the type 6BK4 tube.

Figure 24 shows the horizontal output and high voltage sections of the CTC7 chassis. The shield cover over the high voltage components has been removed to show the location of these parts.

AGC

The AGC circuit shown in the schematic diagram, figure 25, uses the triode section of the 6AW8A 1st Video Amplifier. Components for the AGC circuit are mounted on the video amplifier printed circuit board PW400 shown in figure 16.

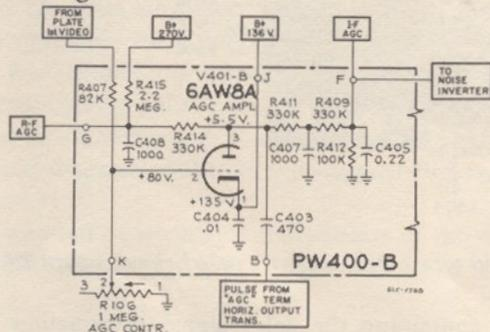

Fig. 25—Schematic diagram—AGC circuit.

Composite video signal is fed to the grid of the AGC amplifier from the plate circuit of the 1st Video Amplifier. The plate of the AGC tube is supplied with voltage derived from a pulse from the horizontal output transformer.

During the time a horizontal pulse is present at the plate, the positive tips of sync at the grid cause the tube to conduct and produce a rectified negative DC voltage at the plate. This voltage is filtered and used for a bias source for the R-F and I-F amplifier stages.

Since the output of the AGC amplifier is proportional to the amplitude of sync tips at the grid input, the R-F and I-F bias, and thus the gain of these stages, is varied in proportion to the sync level received. If the received sync level drops, the AGC amplifier conducts less, and less bias is applied to the R-F and I-F stages which increases the gain of these stages. If the level of received sync increases, the AGC stage provides greater bias and the gain of the R-F and I-F stages decreases.

A block diagram of the AGC circuit is shown in figure 26.

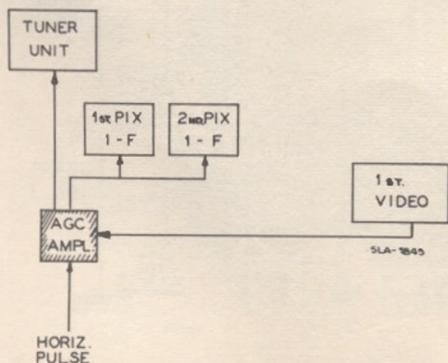
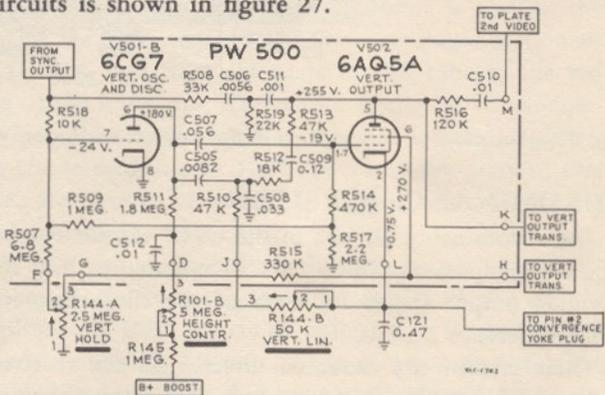

Fig. 26—Block diagram—AGC circuits.

Adjustment of AGC in the CTC7 chassis differs from previous color receivers in that the AGC control is preset at the factory and normally requires no adjustment. If adjustment should be required for any reason it is recommended that a meter, or other indicating device, be connected to terminal "D" of the printed circuit board PW400 (video board) and the AGC control adjusted to show a reading of 10 volts P-P at this point. If the AGC control is not adjusted in this manner, degradation of color rendition may occur.

VERTICAL DEFLECTION

The vertical deflection stages consist of the vertical oscillator, one triode section of a 6CG7, and the vertical output tube, a 6AQ5A. A schematic diagram of these circuits is shown in figure 27.



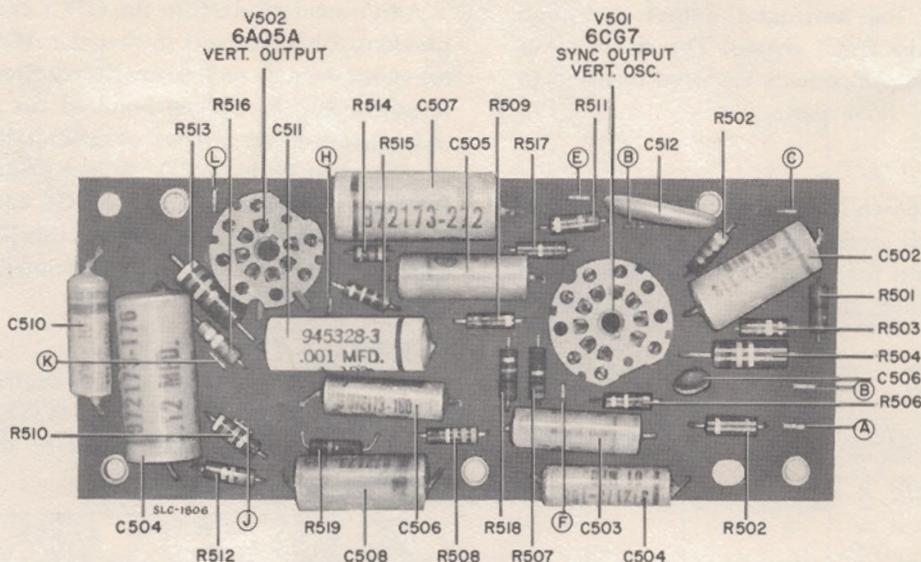

Fig. 29—Location of components in the vertical oscillator, vertical output and sync output stages. Printed circuit board PW500.

CHROMINANCE CIRCUITS

The chrominance circuits in the CTC7 chassis consist of two bandpass amplifiers, two demodulators, and individual output stages for each of the three primary color difference signals.

These circuits are mounted directly on the receiver chassis and do not use the printed circuit construction. A schematic diagram of the chrominance circuits is shown in figure 30.

1st Bandpass Amplifier

Video information is coupled from the plate of the 1st video amplifier to the grid of the 1st bandpass amplifier. This stage, using the pentode section of a 6U8A, has its output circuit tuned to pass the range of fre-

quencies containing the color signal information (the region in the vicinity of 3.58 mc. above the picture carrier frequency). The output of the 1st bandpass amplifier is fed to the grid of the 2nd bandpass amplifier; and to the grid of the burst amplifier in order to extract burst (the color synchronizing signal). T-701, the 1st bandpass transformer, is tuned to pass the band of frequencies mentioned above. L-702, in the grid circuit of the 1st bandpass amplifier, is a peaking circuit to boost the "valley" (usually associated with a double-tuned transformer (T-701) response) so that an overall reasonably "flat-topped" response in the color signal frequency range will be presented to the 2nd bandpass amplifier.

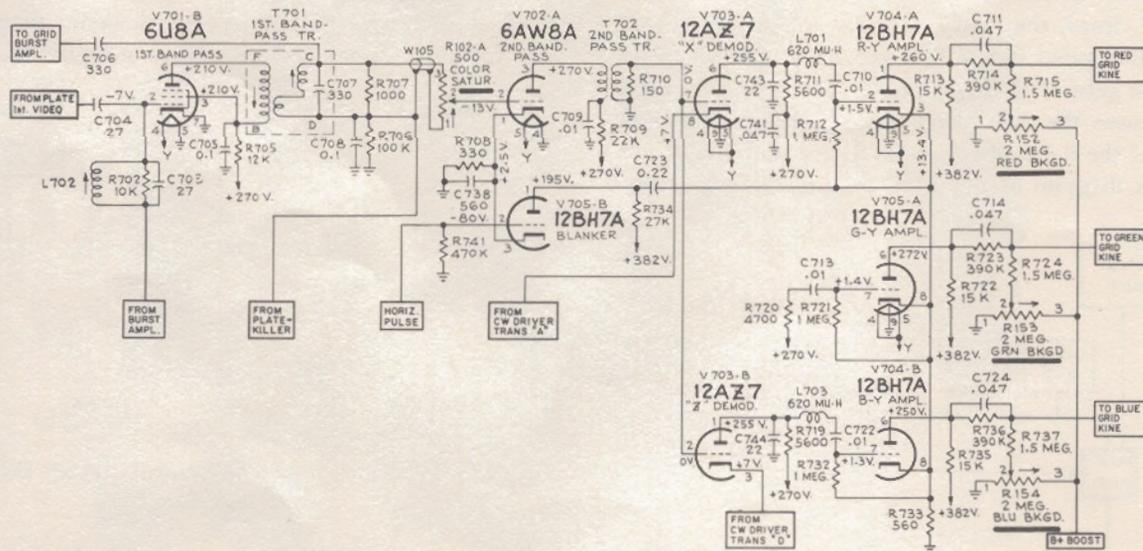

Fig. 30—Schematic diagram—chrominance circuits.

2nd Bandpass Amplifier

The 2nd bandpass amplifier uses the triode section of a 6AW8A. The output of this stage is coupled through T-702 to the grids of the two chrominance demodulators. The color saturation control in the grid circuit of the 2nd bandpass amplifier limits the chrominance drive to this stage. This affects the output to the demodulators, and thus controls the saturation, or intensity, of the colors on the screen of the kinescope.

Color "killer" action is implemented by the bias, developed in the color killer stage, applied to the grid of the 2nd bandpass amplifier. When bias from the killer stage is present, the 2nd bandpass amplifier stage is cut-off and chrominance information is not passed to the demodulators, thus, no color presentation will appear on the kinescope.

A block diagram of the chrominance circuits is shown in figure 31.

The location of the major components in the chrominance and color sync stages is shown in figure 32.

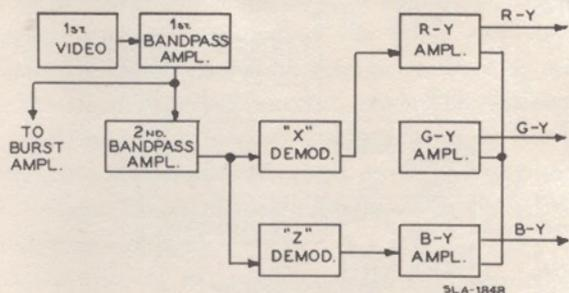

Fig. 31—Block diagram—chrominance circuits.

Demodulators

The chrominance signal from the output of the 2nd bandpass amplifier is applied to the grids of the two triode demodulator tubes. These two triodes are in a single envelope tube, a 12AZ7.

Each of the triode sections operates independently, with one section as the "X" demodulator and the other as the "Z" demodulator.

"X" and "Z" are arbitrary designations given to the demodulation axes. In the CTC7 chassis the "X" and "Z" axes are separated by 57.5 degrees.

By the process of synchronous detection, the demodulator plate voltages vary in amplitude continuously proportional to the amplitude and phase of the chrominance signal.

The output of the "X" demodulator is fed to the grid of the R-Y matrix amplifier, one triode section of a 12BH7A, and from the plate of this tube to the red grid of the kinescope. The output of the "Z" demodulator is applied to the grid of the B-Y matrix amplifier, one triode section of a 12BH7A. From the plate of this tube, the blue color difference signal is applied to the blue grid of the kinescope.

A portion of both demodulator output signals is present in the common cathode circuits of the matrix amplifiers. A third matrix amplifier, with its grid at AC ground potential, has its cathode common to the other two matrix amplifiers. A common cathode resistor serves for all three matrix amplifiers. The G-Y color difference signal is developed in the plate circuit of the G-Y matrix amplifier. This (green) color difference signal is applied to the green grid of the kinescope.

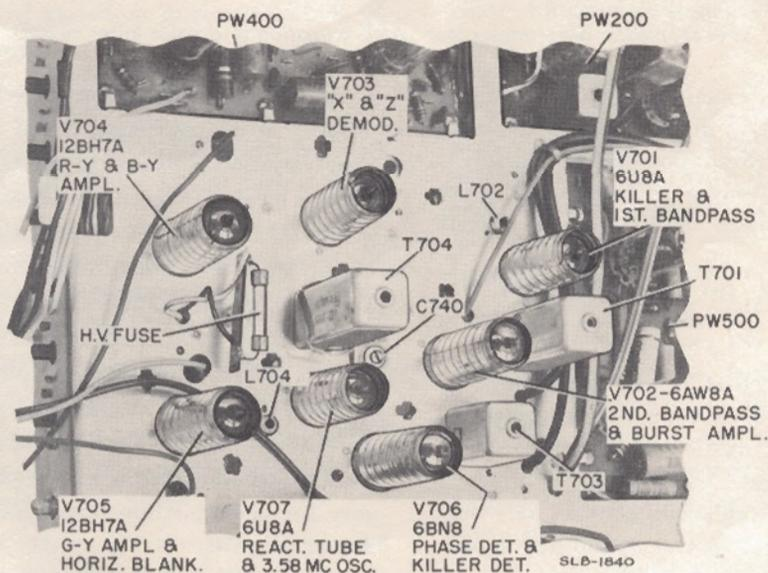

Fig. 32—Component location on the chassis—chrominance and color sync circuits.

Color Synchronization

A schematic diagram of the color synchronization circuits is shown in figure 33.

In order for the color signal to be demodulated by the synchronous detection action in the demodulators, a locally developed subcarrier reference signal is required.

This is provided by the crystal-controlled 3.58 mc. oscillator, the pentode section of a 6U8A.

Output from this oscillator is applied to the cathodes of the demodulators through the cw driver transformer, T-704. The proper phase of subcarrier reference signal applied to the demodulators is determined by the crystal, the reactance control tube, and the tuning of T-704.

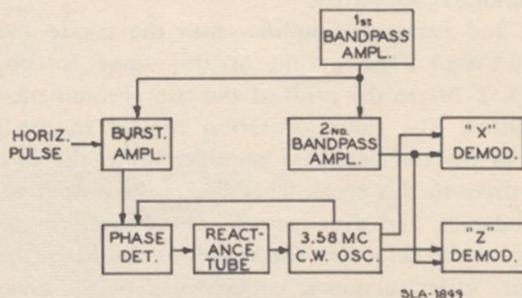

Fig. 34—Block diagram—color synchronization circuits.

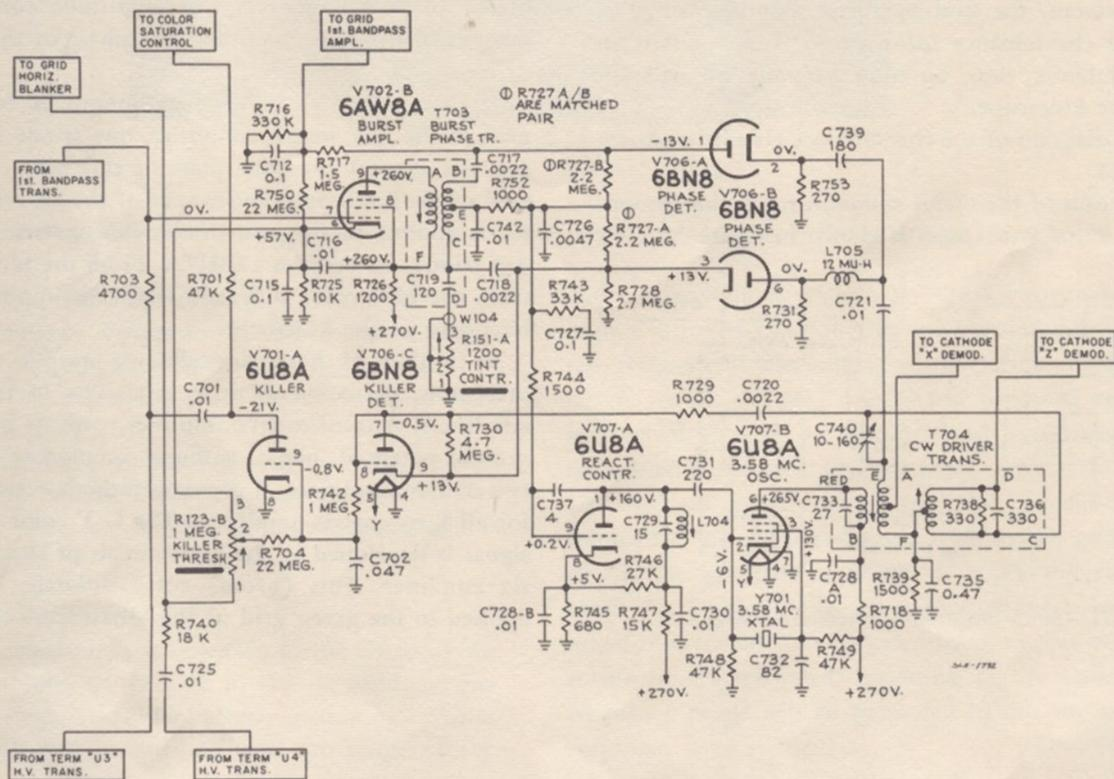

Fig. 33—Schematic diagram—color synchronization and color killer circuits.

Color synchronization is obtained by developing a signal which matches, exactly in frequency and phase, the transmitted color synchronization signal (burst).

This is accomplished by feeding the burst signal from the output of the first bandpass amplifier to the grid of the burst amplifier.

A block diagram of the circuits in the color synchronization section of the receiver is shown in figure 34.

A pulse from the horizontal output transformer is delayed to coincide with burst time in the composite transmitted signal. This follows the horizontal sync pulse at a predetermined time. By delaying the pulse at the burst amplifier grid, this tube will conduct only during the time burst is present in the transmitted signal. Since the tube conducts when burst is present at its grid, burst will appear amplified in its output transformer, T-703. The amplified burst signal is fed through the transformer to the phase detector, two diode sections of a 6BN8.

A portion of the subcarrier reference signal from the local 3.58 mc. oscillator is fed to the phase detectors. Any variation between the phase of burst and the phase of the local 3.58 oscillator results in an error voltage across R727-B and R727-A. The error voltage is applied to the reactance control tube which effects the necessary phase correction in the 3.58 mc. oscillator.

As the 3.58 mc. oscillator is driven to produce the correct phase (to match the phase of burst), the correction voltage developed by the phase detector drops to zero and the 3.58 mc. signal applied to the cathodes of the demodulators is in the phase relationship necessary for demodulation to produce the proper color difference signals.

When this happens, color synchronization is effected since the phase of burst and the phase of the locally generated 3.58 mc. subcarrier reference signal are the same and the color signal information is demodulated to produce the original colors transmitted.

Automatic Chroma Control

The block diagram, figure 35, shows the circuits from which automatic chroma control is derived.

Automatic control of the chrominance level is effected by applying a rectified version of the amplified burst signal to the grid of the 1st bandpass amplifier.

Operation of the automatic chroma control circuit may be compared roughly with AGC operation.

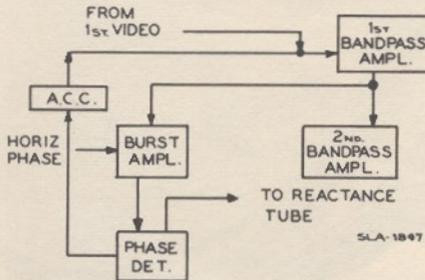

Fig. 35—Block diagram—automatic chroma control circuits.

As the burst signal increases in amplitude, the burst voltage from the output of the burst amplifier increases. This increased burst voltage, rectified by one of the diodes of the phase detector, produces an increase in the voltage applied as a bias to the grid of the bandpass amplifier. As a result, the stage provides less gain and thus limits the amplification of the color signal to the predetermined level.

A decrease in the received burst level would result in the opposite effect. Less burst would develop a lower bias at the grid of the 1st bandpass amplifier, more gain in this stage, and the color signal would be amplified to the predetermined level.

By this means, the color picture remains at a constant color level, regardless of variations in the amplitude of the received burst signal.

Color Killer

The color killer circuit in the CTC7 chassis prevents color from appearing in the picture except during reception of a color program.

To accomplish this, the color killer circuit causes the 2nd bandpass amplifier to become inoperative during the absence of the color synchronization signal (burst) normally transmitted with the color program. A block diagram of the color killer circuits is shown in figure 36.

A portion of the output of the 3.58 mc. subcarrier oscillator is applied to the plate and grid of the killer detector, the triode section of a 6BN8.

When burst is present in the received signal, the phase detector will operate. The burst signal applied to the phase detector is also applied to the cathode of the killer detector.

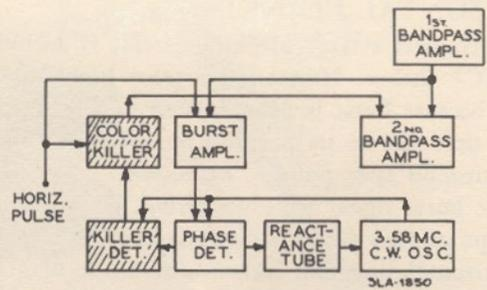

Fig. 36.—Block diagram—color killer circuit.

When the signal applied to the plate and grid of the killer detector from the 3.58 mc. oscillator is 180° out of phase with the signal applied to the cathode of the killer detector from the phase detector, the tube conducts and a bias voltage is developed at the grid of the color killer tube. This voltage overcomes the normal bias on the grid of the color killer and causes this tube to stop conducting. The output of the color killer is applied as a bias to the grid of the 2nd bandpass amplifier.

When the killer is conducting, the 2nd bandpass amplifier is cut off, no signal is applied from its output circuit to the grids of the "X" and "Z" demodulators, and color information is not applied to the grids of the kinescope.

When the color killer does *not* conduct, the 2nd bandpass amplifier operates with normal bias and any signal present in its grid circuit will be amplified and passed to the demodulators.

Thus, when a color program is received, the bias voltage developed by the killer detector (happening only during the time burst is present) overcomes the killer bias, the 2nd bandpass amplifier operates, and color information is passed to the grids of the kinescope.

When burst is not present, only the signal from the 3.58 mc. subcarrier oscillator will be present at the plate and grid of the killer detector. The tube will not conduct, since only when burst is present will there be sufficient voltage at the cathode to cause conduction. The color killer will apply bias to the grid of the 2nd bandpass amplifier sufficient to cut off the tube and prevent operation of this stage.

In this manner, since the presence of burst, its phase, and the phase of the signal from the 3.58 mc. subcarrier oscillator are the determining factors for operation of the killer circuit, noise impulses cannot cause the 2nd bandpass amplifier to operate, and the black-and-white picture will be free of color caused by impulse noise.

The operating level of the color killer circuit is preset by the killer threshold control shown in the schematic diagram, figure 33.

HORIZONTAL BLANKING

A horizontal retrace blanking circuit is included in the CTC7 chassis. Horizontal retrace blanking is required because burst is demodulated during horizontal retrace time due to its position immediately following the horizontal sync pulse.

If the burst signal were permitted to appear at the kinescope grids, a yellow stripe would be visible during the horizontal blanking interval. A block diagram of the horizontal blanking circuits is shown in figure 37. The schematic diagram of this circuit is included in figure 30.

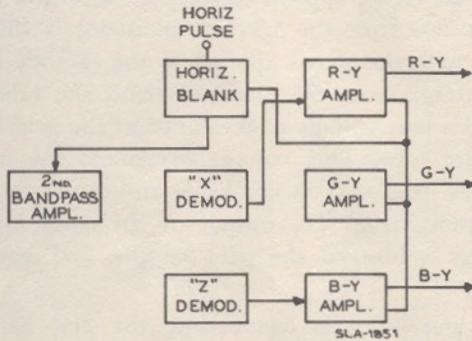

Fig. 37—Horizontal retrace blanking circuit.

Horizontal retrace blanking is accomplished in the CTC7 chassis by applying a horizontal pulse to the grid of one triode section of a 12BH7A, the horizontal blanking amplifier.

This pulse is applied from the cathode of the horizontal blanking amplifier to the cathode of the 2nd bandpass amplifier. This causes the 2nd bandpass amplifier to be cut off during horizontal retrace time, thus preventing color information from being passed to the kinescope grids during this time.

In addition, the horizontal pulse is coupled from the plate of the horizontal blanker to the common cathodes of the three matrix amplifiers. The horizontal pulse at their cathodes causes these tubes to draw large currents during retrace. This reduces their plate voltages during this time. The plate voltages of the matrix amplifiers may be considered the grid voltages for the three control grids in the kinescope. Thus, when the matrix amplifier plate voltages are reduced, the kinescope grid voltages are reduced to the point where the kinescope is blanked during horizontal retrace time. At the same time, the pulse causes the matrix amplifiers to re-set the DC level of the color signals.

KINESCOPE

The 21CYP22 glass-envelope tricolor kinescope introduced in the 800 series color receivers is similar to the previously used metal envelope kinescope.

The 21CYP22 is a directly viewed, round picture tube which produces a picture, in either color or black-and-white, having an area of approximately 261 square

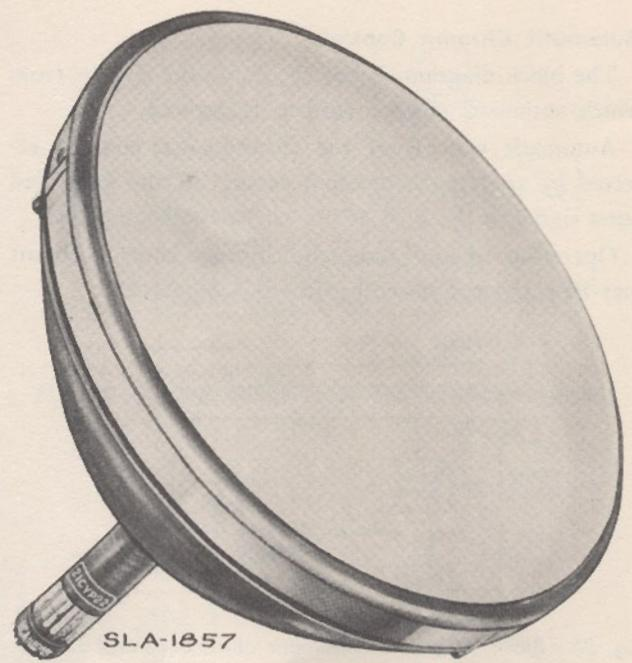

Fig. 38—21CYP22 glass-envelope tricolor kinescope.

inches. It features magnetic sweep deflection, electrostatic focus, magnetic convergence; a shadow mask and an aluminized phosphor-dot screen with the dot trios arranged in orderly groups.

An internal conductive coating, similar to that used in black-and-white picture tubes, is used in conjunction with an external bulb coating to form a supplementary filter capacitor for the high voltage.

The kinescope accessories, which include the deflection yoke, convergence yoke, lateral beam-positioning magnet, and the purity magnet are shown in figure 39.

Two other aids for accuracy and ease of achieving overall color purity are the edge purity and the "Z" purity coil.

In previous color receivers the edge purity magnets were called "color equalizing magnets." They were installed about the periphery of the faceplate end of the kinescope and were used for correcting color impurities caused by stray magnetic fields near the outer edges of the kinescope. The new edge purity magnets perform a similar function but are installed on the kinescope pull-up ring mounting assembly near the bell end of the kinescope as shown in figure 40. The edge purity magnets are hairpin-shaped magnetized bars. To achieve the desired corrective effect near the edges of the kinescope screen, the magnets are rotated on their insulated mountings.

The "Z" purity coil is another auxiliary purity device installed on early production receivers. This coil consists of a few loops of heavy wire at the periphery of the faceplate end of the kinescope. Its purpose is to correct color impurity effects caused by stray magnetic fields affecting the "Z" axis (lengthwise from faceplate to socket) of the kinescope.



Fig. 39—Kinescope accessories used with the CTC7 chassis.

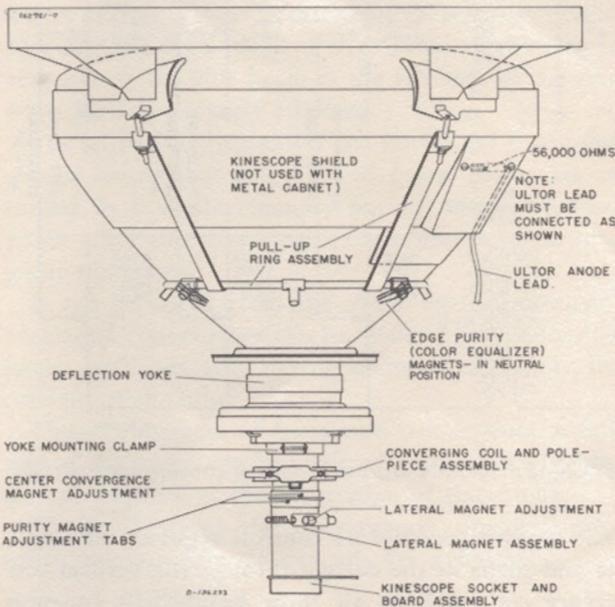

Fig. 40—Location of accessories installed on 21CYP22 tri-color kinescope.

A momentary-contact push-button switch on the rear of the chassis discharges a capacitor through the coil to achieve magnetization of metal components in the immediate vicinity to give the desired purity improvement.

A variable resistor connected across the coil, is part of the purity switch. Adjustment of the resistor varies the direction and strength of the magnetic field about the "Z" purity coil when energized.

Kinescope Controls

The kinescope has three different sets of phosphors deposited on the viewing screen. Each of the sets of phosphors, because of the difference in phosphor efficiencies, requires a different value of excitation to produce the same amount of light output.

This difference in drive to the cathodes is accomplished by a voltage divider network in the plate circuit of the 2nd Video Amplifier.

In order to set-up the kinescope for the proper values of red, green, and blue light output on the kinescope, the output of each gun is controlled by the voltage applied to the screen grid of each gun. These individual controls are the red, green and blue screen controls R-109, R-110 and R-111 shown in figure 41.

The red, green and blue background controls (refer to figure 30, page 16) together with the screen controls serve to adjust the overall color balance to produce a black-and-white picture without an overall color-caste.

The screen and the background controls are mounted on the rear apron of the chassis.

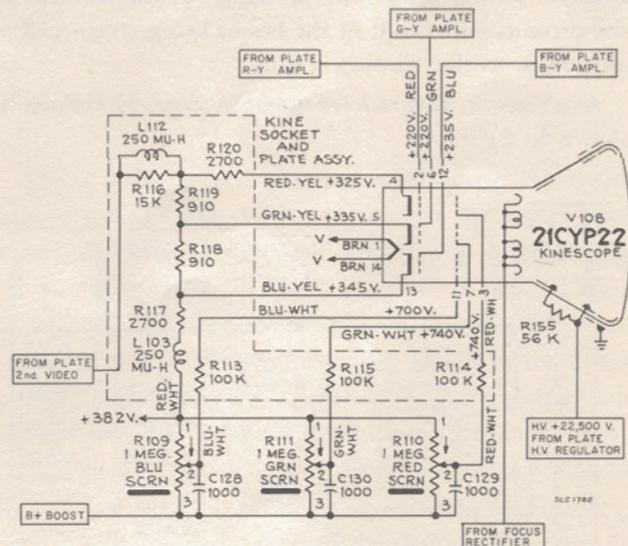

Fig. 41—Kinescope circuit.

CONVERGENCE

In the 21CYP22 tricolor kinescope the three electron beams must converge at every aperture in the shadow mask.

When the beams do not converge at every aperture in the mask the beams will excite phosphors other than those for which they were intended and color fringing (misconvergence) will be seen on the test pattern or picture shown.

In the 800 series color receivers using the CTC7 chassis the beams are caused to converge at the center of the screen by the mechanical alignment built into the electron guns, and with adjustable permanent magnets over the three individual electron gun convergence pole pieces. Adjustments which refer to center convergence are made by positioning these magnets closer to, or further away from the neck of the kinescope. The center convergence magnets are shown in figure 39.

Convergence at points other than the center of the kinescope screen is maintained by controlling the intensity of magnetic field about each of the convergence pole-pieces built into the kinescope electron guns.

A coil and core assembly, shown in the convergence yoke, figure 39, is placed perpendicular to each convergence pole-piece in the kinescope.

Currents derived from the horizontal and vertical sweep output stages are applied to the coil windings. Each of the three coil and core assemblies consists of a coil for the vertical currents and a separate coil for the horizontal currents. Thus, the separate electron beams are affected by the magnetic fields set up by the currents through the coils. Since the currents through the coils are synchronized with scanning, proper control of the currents will result in the beams being converged at all points on the viewing screen.

A schematic diagram of the convergence circuits is shown in figure 42.

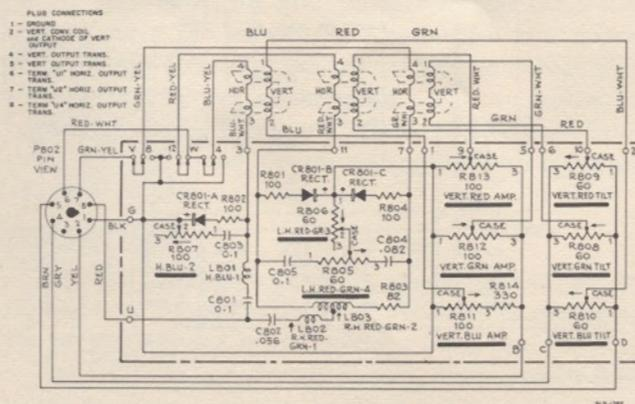

Fig. 42—Schematic diagram—convergence circuits.

Current from the cathode of the vertical output tube is shaped by C121 and L111, and applied to the vertical convergence coils through the vertical amplitude controls. These controls limit the amplitude of the current applied to the coils.

The vertical convergence coils are also supplied with current from the vertical output transformer through variable resistors. These are called the vertical "tilt" controls.

As shown in the schematic diagram of the vertical convergence circuits, figure 43, the vertical tilt controls assist in further shaping of the current applied to the vertical convergence coils by supplying current in either the positive or negative direction, through the variable resistors, to add to or subtract from the current supplied to the coils from the cathode of the vertical output tube.

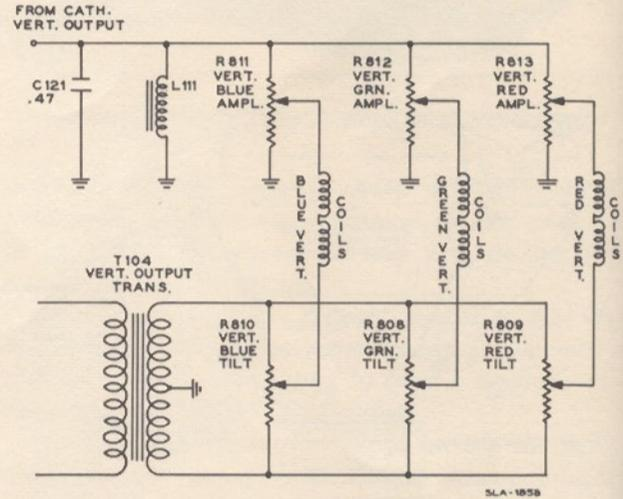

Fig. 43—Schematic diagram—vertical convergence circuits.

The vertical convergence controls regulate the amplitude and shape of the current through the vertical convergence coils so that all three beams will converge vertically on the kinescope screen.

Current is supplied to the horizontal convergence circuits from the horizontal output transformer.

In the schematic diagram of the horizontal convergence circuits, figure 44, L801 and C801 adjust the amplitude and shape of the current through the blue horizontal convergence coil so that only the right side of the screen is affected. R807, C803 and CR801A are a timing circuit which controls the shape of the waveform affecting horizontal convergence of the blue beam at the left side of the screen. Adjustment of the core of the coil (L801) varies the inductance of the coil and thus advances or slows down the current peak so that as the blue beam sweeps across the right side of the kinescope the magnetic field set up in the coil by the horizontal convergence current is automatically controlled (by the shape of the horizontal current) to cause the blue beam to converge at the right side of the screen.

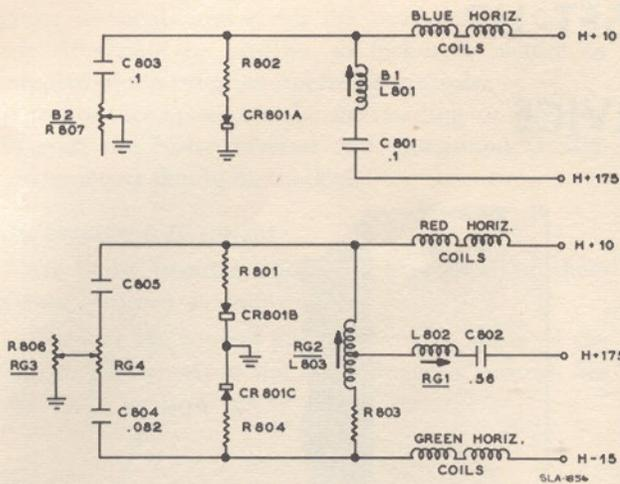

Fig. 44—Schematic diagram—horizontal convergence circuits.

The amplitude of the pulse, when it tends to change in polarity, is controlled by R807, which determines the length of time it takes to discharge C803 across CR801A. This controls the portion of the waveform affecting convergence of the blue beam at the left side of the screen when L801 is properly adjusted.

The schematic diagram of the horizontal convergence circuits shows that the red and green beams are controlled in a similar manner but by common controls which affect the convergence correction voltages in opposite directions.

It can be noted from the above that adjustment of horizontal convergence can be made at both sides of the screen with one side having controls essentially independent of the other.

Thus, adjustment of horizontal convergence at either side of the screen can be made without materially affecting convergence at the other edge of the screen.

Figure 45 shows the convergence control panel on which the convergence controls are mounted.

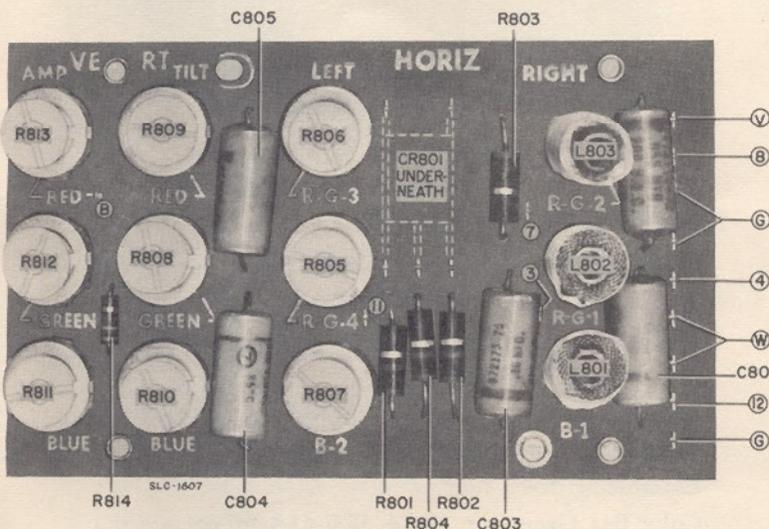

Fig. 45—Component locations on convergence control panel. Printed circuit board PW800.

LOW VOLTAGE POWER SUPPLY

The low voltage power supply provides the 382-volt and 270-volt B-plus sources in the receiver and the heater current for all tubes except the high-voltage and focus rectifiers.

The full-wave rectifier circuit uses two type 5U4GB tubes in parallel. This insures full-wave rectification in the event of failure of one of the tubes.

Power supply components are protected by a 2.0 ampere fuse of the wired-in type connected between the rectifier output and the input filter capacitor.

Two separate heater windings are used. One winding supplies heater voltage for all tubes except the kinescope and shunt regulator. This winding is fused with a length of #22 magnet wire covered with flexible glass sleeving. The other winding supplies the kinescope and the 6BK4 shunt regulator. This winding is operated at 270 volts DC above ground.

A schematic diagram of the low voltage power supply is shown in figure 46.

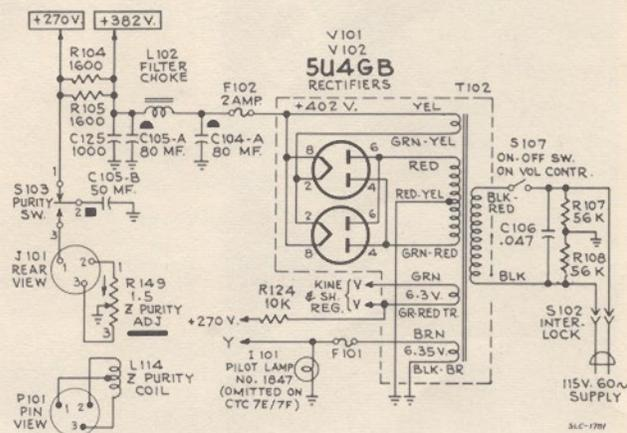

Fig. 46—Schematic diagram—low voltage power supply.

The .047 mfd. capacitor connected across the terminals of the 117 volt AC input interlock attenuates horizontal deflection frequencies which may radiate from the power cord.

Two 56,000-ohm resistors, connected between ground and each side of the AC line at the interlock terminals, provide a leakage path to ground for any electrostatic charges that may be present on the chassis.

Current for operation of the "Z" purity coil, used in early production receivers is obtained by discharging, with a momentary-contact switch, the current stored in the capacitor C105B normally used as a filter capacitor in the power supply.

RECEIVER SET-UP

AND SERVICE

RECEIVER SET-UP CONSIDERATIONS

The color receiver must first be set-up for proper black-and-white reception. Conventional adjustments of height, vertical linearity, focus, centering and operation of the horizontal hold control are required. The AGC control is pre-set at the factory and should not require adjustment in the field. The Noise Inverter control should be set for best signal-to-noise ratio on weak signal without causing overload on strong signals. See figures 47 and 48 for location of controls.

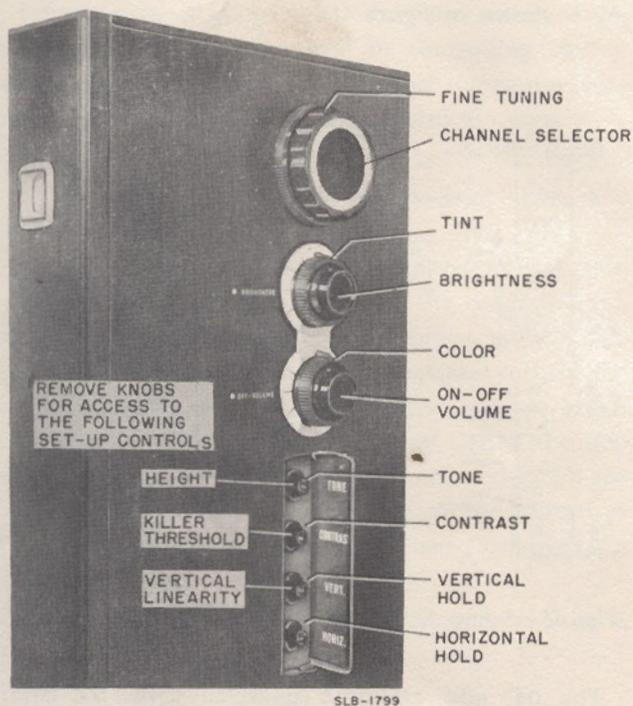
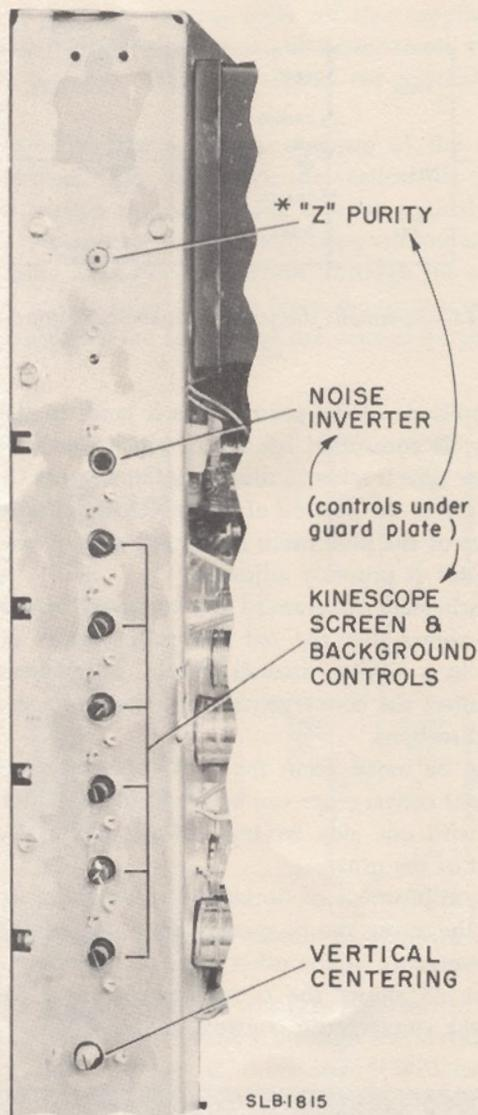

Fig. 47—Customer operating controls and set-up controls.

The receiver incorporates a three-beam tricolor kinescope. The operation of the kinescope must be checked for proper convergence, purity and color temperature since these adjustments must be correct before good black-and-white pictures, free of color fringing and color shading, can be produced on the screen of the kinescope. The application of techniques involved in making kinescope circuit adjustments mark the major difference between the set-up procedure for black-and-white television receivers and color television receivers.



* not incorporated in all chassis

Fig. 48—Controls on rear apron of chassis.

EQUIPMENT REQUIRED

The following equipment is desirable in performing certain set-up adjustments on the color receivers.

- Vacuum-Tube Voltmeter (RCA "VoltOhmyst" WV-98A or equivalent)
- Dot-Bar Generator (RCA WR-36A or equivalent)
- Demagnetizing Coil
- Portable Mirror
- Color-Bar Generator (RCA WR-61A or equivalent)
- Kinescope Control-Grid Switch

CHASSIS SET-UP ADJUSTMENTS

Connect the antenna transmission line to the receiver antenna terminals and check the operation of the receiver. It should be possible to lock-in a picture by manipulating the customer operating controls.

If the picture appears to be overloading or does not hold sync, the Noise Inverter and Horizontal Oscillator adjustments should be checked.

Noise Inverter Adjustment

When Noise Inverter adjustment is required on these receivers, proceed as follows:

1. Remove the control guard from rear apron of the chassis to gain access to the Noise Inverter control. See figure 49.

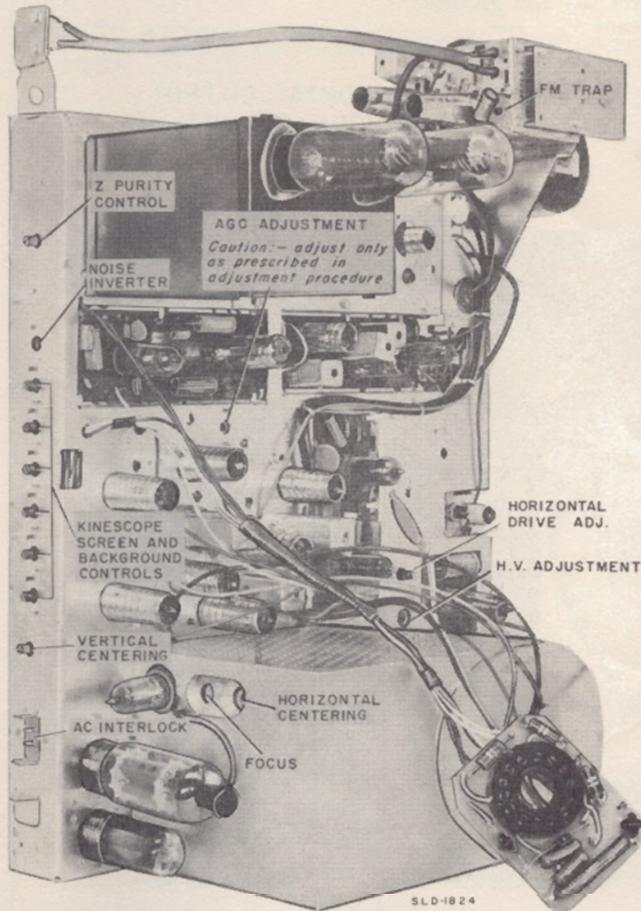

Fig. 49—Location of set-up adjustments—CTC7 chassis.

2. Switch the receiver to the weakest channel to be received.
3. Adjust the Noise Inverter control clockwise until the best signal-to-noise ratio is obtained.
4. Check the strongest signal and make certain that the adjustment of the Noise Inverter control did not cause overload. The Noise Inverter control should be set for best signal-to-noise ratio without causing overload on strong signals.
5. Replace the control guard on rear apron of chassis.

NOTE

The AGC control is not intended for adjustment in the field. It is pre-set at the factory and normally requires no further attention. When necessary however, it may be adjusted by connecting an oscilloscope or "VoltOhmst" to terminal "D" of PW400 and adjusting the AGC control (see figure 49) for an indication of 10 volts peak-to-peak on a strong signal.

Height, Vertical Linearity and Vertical Centering Adjustments

Remove the Tone and Vertical Hold Control knobs to gain access to the Height and Vertical Linearity Controls, see figure 47. Adjust these controls until the picture is symmetrical from top to bottom overscanning the mask by one inch at both top and bottom.

Adjust the Vertical Centering Control, located on chassis rear apron, to center the picture vertically in respect to the mask. Refer to figure 49 for control location.

Focus Adjustment

Adjust the Focus Control to obtain maximum overall definition of fine picture detail. This control is located on the rear of the high voltage compartment as shown in figure 49.

Horizontal Centering and Width Adjustments

To center the raster on the kinescope screen, adjust the Horizontal Centering Control. This control is located on the rear of the high voltage compartment as shown in figure 49. Under normal operating conditions, assuming the horizontal deflection circuits are adjusted properly, the raster should overscan the masking area by approximately three-quarters of an inch on each side. When necessary, the width may be expanded by moving the blue/white lead from position D, normal position, to position #2 on the deflection yoke as shown in figure 50.

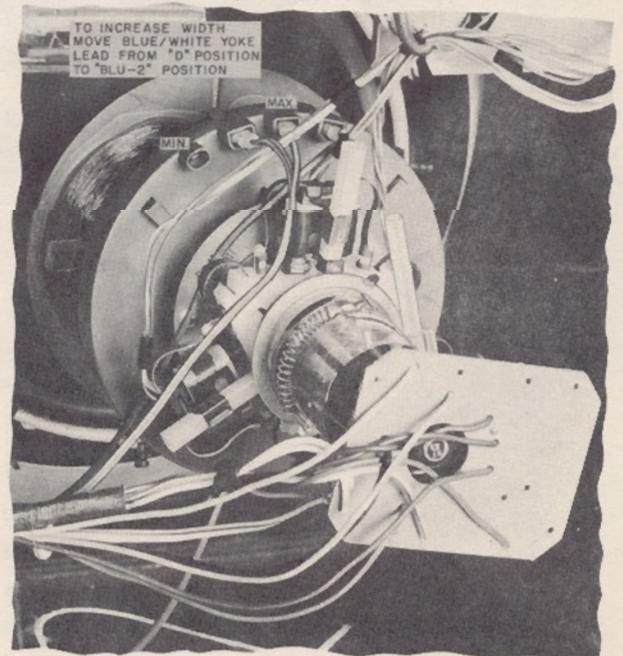

Fig. 50—Width adjustment—CTC7 chassis.

Horizontal Drive and Efficiency Adjustments

Adjustment of the horizontal drive and efficiency controls affect the operation of the high-voltage section of the receiver. These adjustments are normally not required during set-up of the receiver since they are pre-set at the factory. However, when necessary, these adjustments should be made as follows:

1. Remove the chassis from the receiver cabinet and disconnect the jumper between pin #3 of V105 and ground. See figure 51.

2. Connect a 0-500 ma. meter between pin #3 of V105, Horizontal Output tube, and ground. *Shunt meter connections with .47 mfd. capacitor.*

3. Turn on the receiver and tune in a synchronized picture. See figure 52 for illustrations of extension cables employed to operate the chassis removed from the cabinet.

4. Adjust L105, Horizontal Efficiency Control, see figure 51, for minimum current on milliammeter.

5. Adjust R135, Horizontal Drive Control, see figure 51, for maximum current without drive line but not in excess of 210 ma. as indicated on the milliammeter.

6. Disconnect the meter and capacitor employed during adjustment and reconnect jumper between pin #3 of V105 and ground.

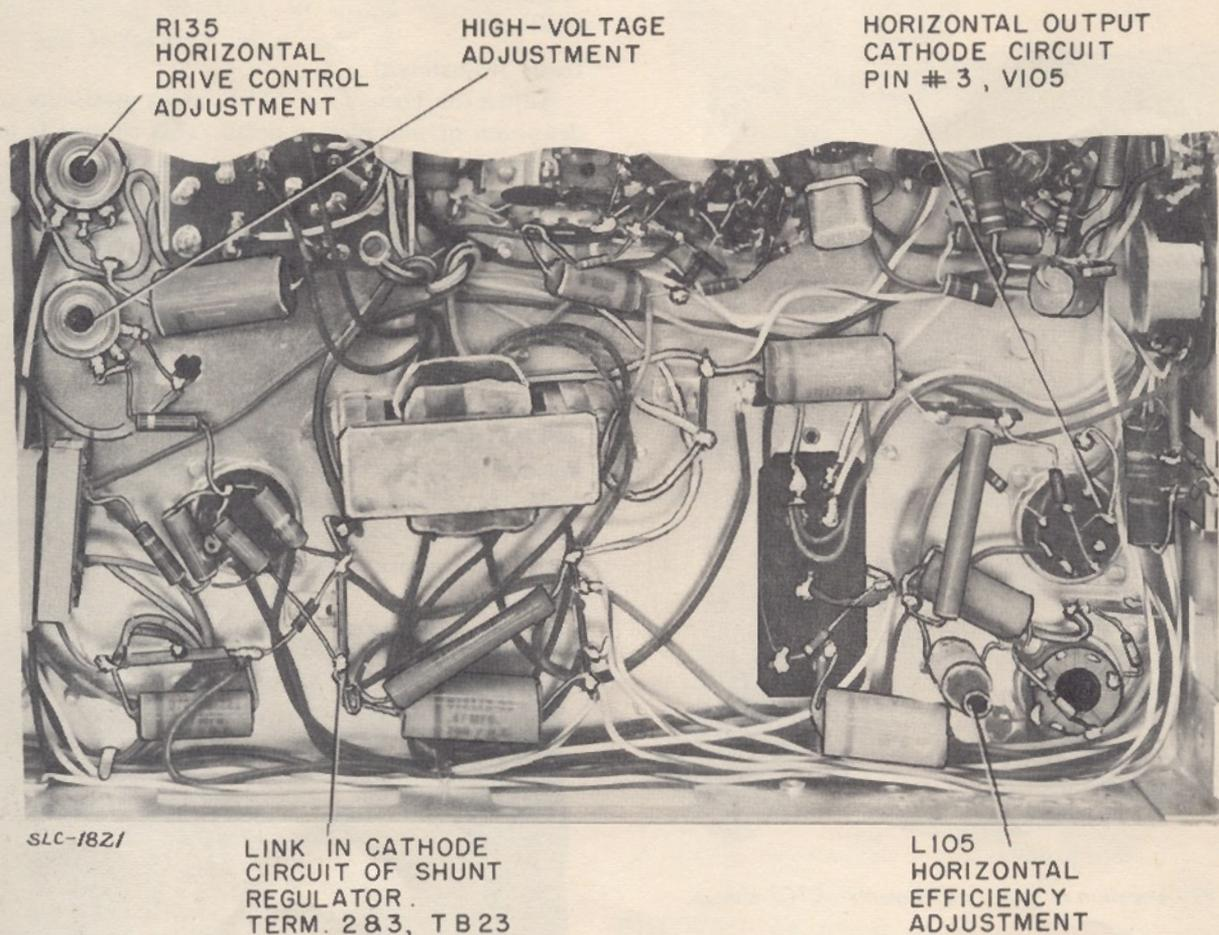

Fig. 51—Location of adjustments in the horizontal output and high voltage circuits.

Horizontal drive can be set in the field without removing the chassis, when absolutely necessary, by turning the control fully clockwise and then counter-clockwise until the drive line in the raster *just disappears*. It is recommended however, that horizontal drive be set using a milliammeter as described above.

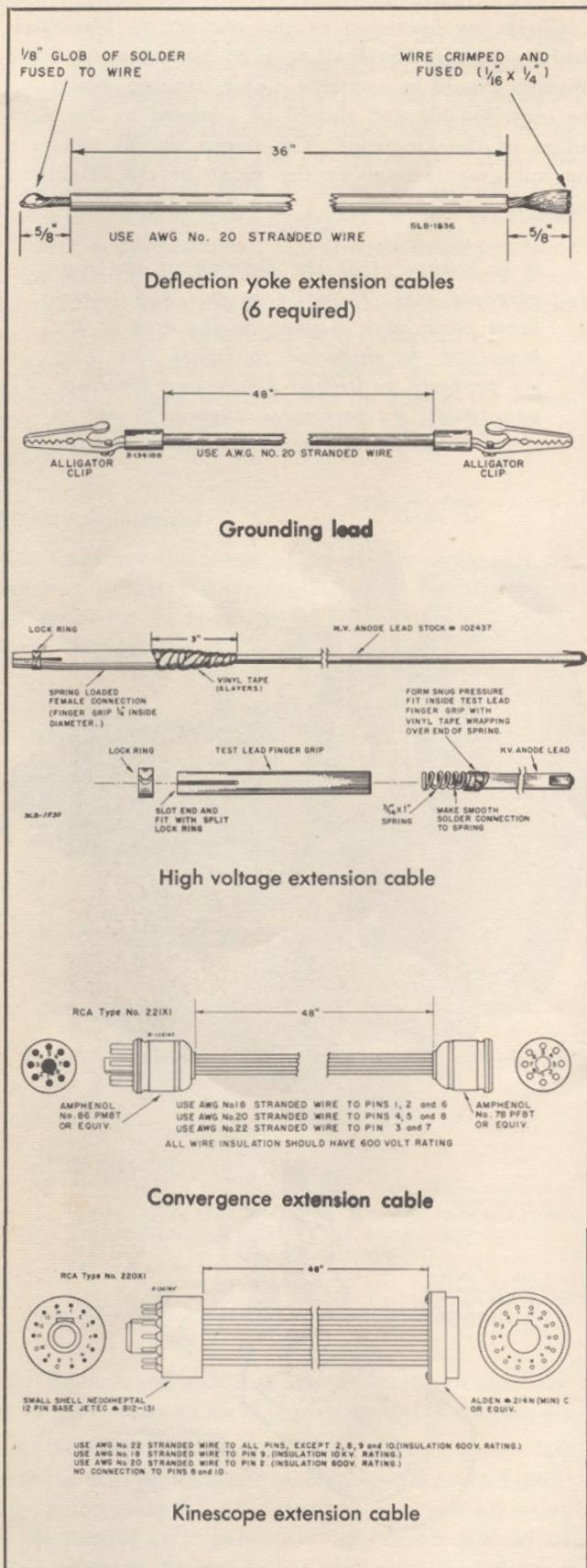

Fig. 52—Extension cables required for operating chassis when removed from cabinet.

High Voltage Adjustment

To perform the high-voltage adjustment proceed as follows:

1. Connect a "VoltOhmyst" via a high voltage probe to the HV rectifier cup as shown in figure 53.
2. Adjust R146, the high voltage control, for 22.5 KV at the HV rectifier cup. Refer to figure 51 or 53.
3. If the chassis is removed from the cabinet connect a 0-1000 ua. meter in series with the cathode lead of V107 Shunt Regulator by opening the jumper between terminals 2 and 3 on terminal board TB 23, as shown in figure 51. The meter should indicate a current of not less than 800 ua. (18 Watts).

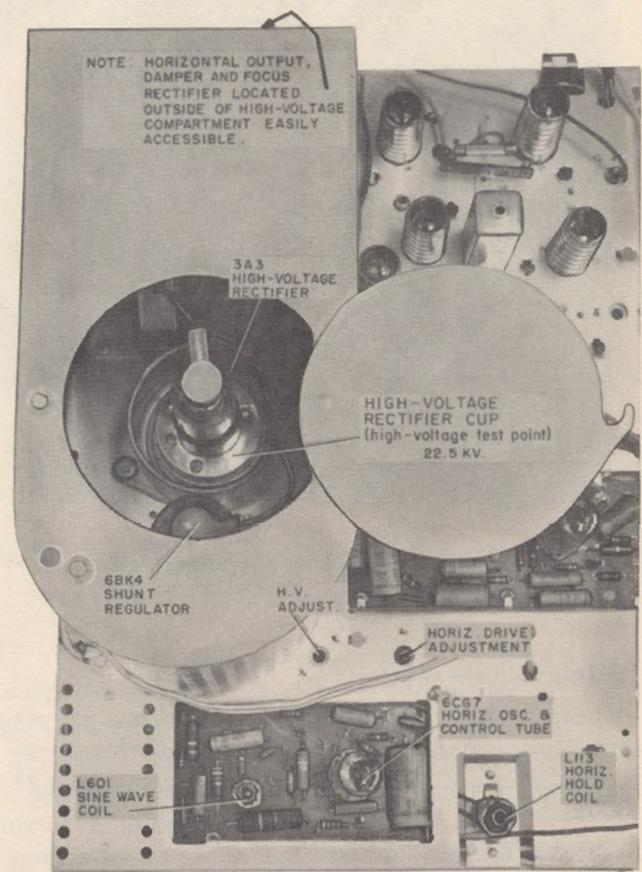

Fig. 53—Top view—horizontal output and high voltage circuit locations CTC7 chassis.

R-F Oscillator Adjustments

Rotate the Channel Selector Control and check all available stations to see that the Fine Tuning control tunes to the center of its range on all channels. When oscillator adjustments are required, remove the fine tuning and channel selector knobs to gain access to the oscillator adjustments as shown in figure 54.

Minor adjustments of the VHF oscillator may be made as follows:

1. Turn the station selector to the *highest* channel to be received and set the fine tuning control at the center of its range.
2. Adjust the overall oscillator tuning adjustment L11, see figure 54, for best picture reception.
3. Turn the channel selector to each channel to be received, progressing from the higher to lower channels and adjust the respective oscillator trimmer for best picture reception. *Retain the fine tuning control at the center of its range during the entire adjustment procedure.*

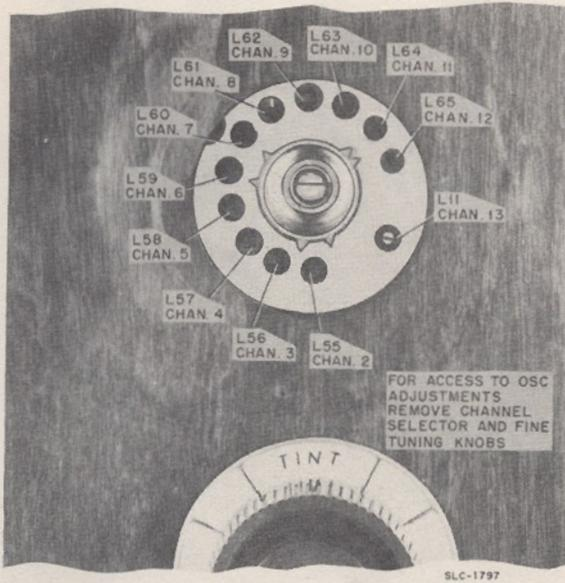

Fig. 54—R-F oscillator adjustment locations—800 Series color receivers.

FM Trap Adjustment

If interference is encountered from a strong FM station signal, adjust the FM trap L5 to minimize the interference in the picture. Refer to figure 49, page 25, for the location of this adjustment.

The FM trap can tune into channel 6 or even channel 5 in some receivers, therefore if either of these channels are to be received, check to make certain that the trap does not affect the sensitivity on these channels.

KINESCOPE SET-UP ADJUSTMENTS

Check the operation of the receiver on black-and-white reception. Check all areas of the screen. No color shading should be apparent. Color fringing should not be objectionable and should be confined to the outer edges of the kinescope. The screen should remain a neutral gray throughout the range of the brightness control.

NOTE

It is essential that the position of the convergence magnet, purity magnet and lateral beam positioning magnet, on the neck of the kinescope, be inspected to insure that they are properly positioned before any kinescope adjustments are performed. Figures 55 and 56 show the proper placement of these assemblies.

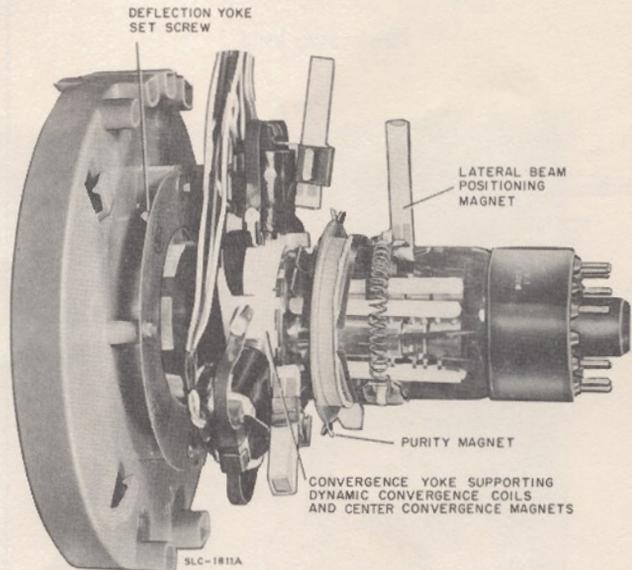

Fig. 55—Positioning of kinescope accessories on kinescope neck.

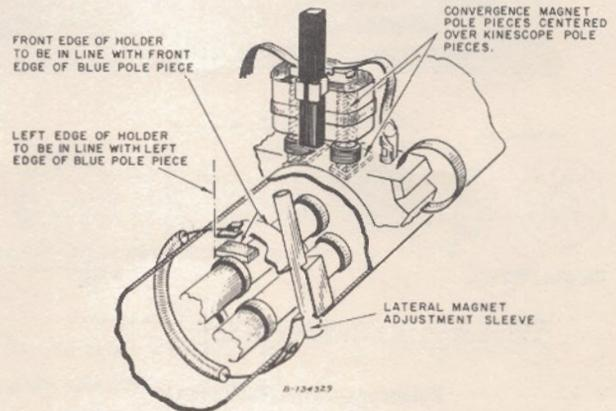

Fig. 56—Location of lateral magnet and convergence magnet pole pieces.

Color Purity Adjustments (Color Shading)

Any color shading apparent within the area of the kinescope screen, while viewing a black-and-white picture indicates that color purity adjustments are required.

If only slight shading exists about the edges of the screen demagnetize the area of the receiver about the kinescope faceplate, with a demagnetizing coil. *Care should be taken to avoid demagnetizing the area about the neck of the kinescope.* The demagnetizing procedure is important since magnetic influences anywhere about the chassis or kinescope will noticeably impair the purity and convergence capabilities of the receiver.

After demagnetizing the area about the face plate of the kinescope check the areas near the edge of the screen. If impurities still exist, use the Z purity control as follows:

Z Purity Adjustment

1. Converge the center of the picture using only the center convergence controls. Use a dot pattern from a dot generator to facilitate the adjustment. Figure 57 shows the location of the center convergence controls.

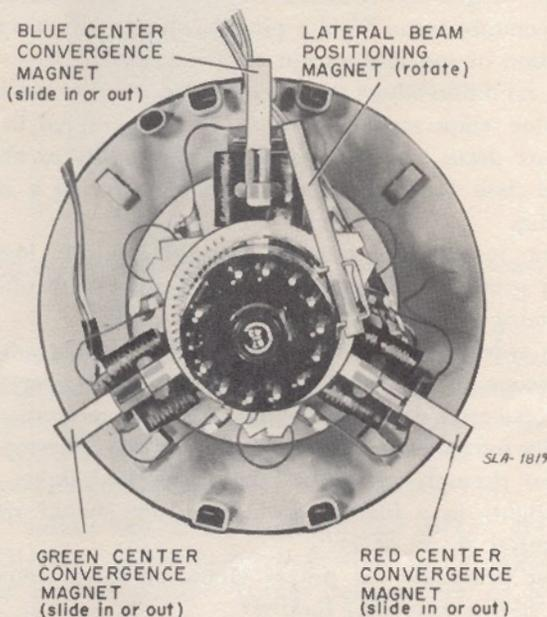

Fig. 57—Location of center convergence magnets.

2. Remove the guard on the rear apron of the chassis to gain access to the Z purity control, see figure 49.

3. Advance the control slightly either right or left from the zero position and push in on the control shaft. *Zero position can be determined by a distinct detenting of the control as it passes over the center part of its range.* Observe the picture for correction of shading at the edges. If the shading improved, but further correction is required, advance the control still further in the

same direction and again push in on the shaft. Continue until best edge purity is obtained.

4. If the shading increases when a particular Z purity control adjustment is made turn the Z purity control to the other side of the zero position and repeat the procedure outlined in step #3 for best edge purity.

After optimum edge purity is obtained return the Z purity control to its zero position.

If color shading can not be obtained by employing the degaussing coil or Z purity adjustments, or if the kinescope has been replaced, the complete purity adjustment procedure should be performed as follows:

1. Using the demagnetizing coil, slowly move the coil around the kinescope, the sides and front of the receiver and very slowly withdraw to about six feet before disconnecting the coil. (Minimum contamination should result from the demagnetizing procedure.)

2. Set the red tabs on the purity magnet together. Refer to figure 55. Set the edge purity magnets (hairpins) to neutral position as shown in figure 58. This is with the two magnets in the same position one above the other.

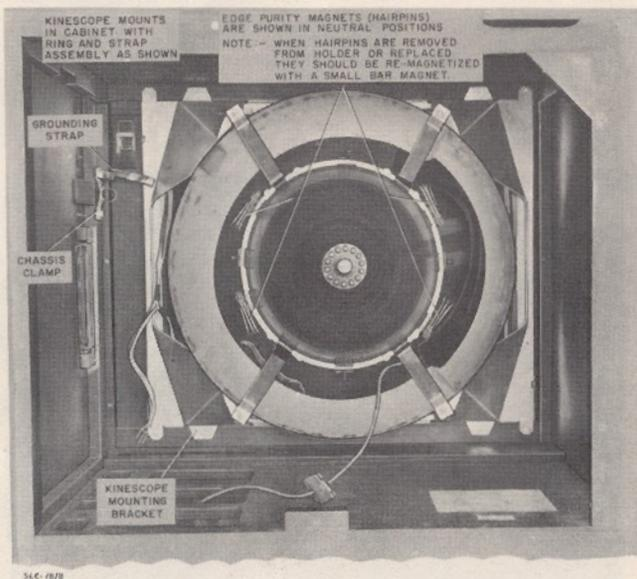

Fig. 58—Edge purity magnets shown in "neutral" position—chassis and kinescope accessories removed.

3. Turn the blue and green screen controls fully counter-clockwise. These controls are located on the rear apron of the chassis as shown in figure 49.

4. Loosen the screw on the yoke clamp, see figure 55, and slide the yoke as far to the rear as possible without disturbing the convergence yoke.

5. Rotate the purity magnet around the neck of the kinescope and at the same time adjust the tabs on the magnet to produce a uniform red screen area, at the center of the kinescope.

6. Move the yoke forward and adjust for best over-all red screen, without neck shadow. *Avoid tilting the raster.* Observe beam landing, using the microscope if desired for optimum accuracy, and check all three screens, turning up the screen control for the screen color being viewed. Adjust yoke position so that any existent purity error falls at the extreme edges of the screen and secure the yoke.

Any color shading, evident in areas near the edge of the screen, normally can be corrected by adjustment of the "Z" purity control as outlined under Z purity Adjustments above.

Perform final purity adjustments after adjusting the screen controls for a white screen. Check the entire area of the screen for any areas still showing edge purity error.

NOTE

Some receivers do not incorporate a Z purity control. Instead, six edge purity magnets are used and all references to Z purity adjustments may be disregarded.

Edge Purity Magnet Adjustment

Any minor edge purity areas existing *after the demagnetizing and Z purity procedures have been completed* can be corrected by adjustment of the edge purity magnets (hairpins). Refer to figure 59 for location of these magnets.

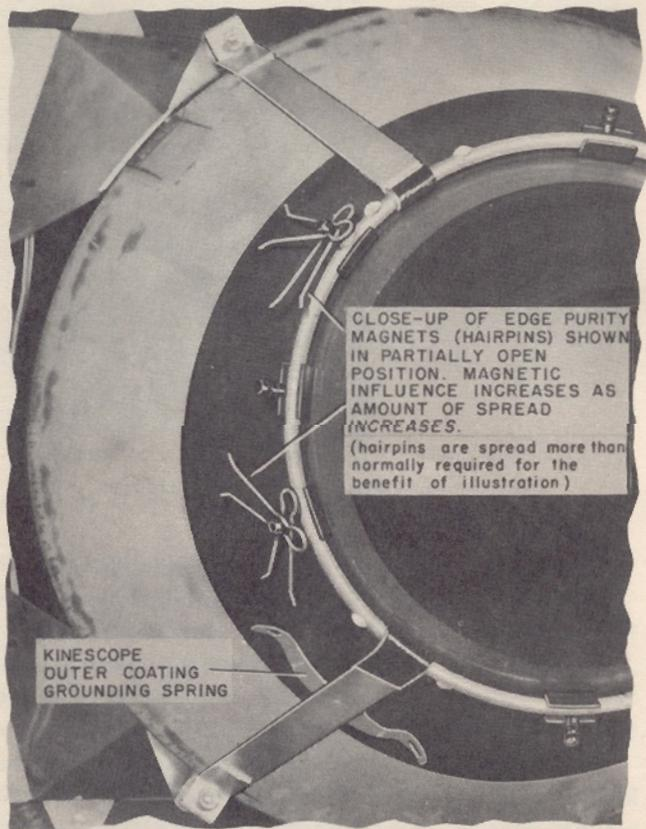

Fig. 59—Adjustment of edge purity magnets.

When the "hairpin" magnets are coinciding minimum beam correction force exists. Spreading the "hairpins" increases beam correction force and rotating them alters the direction of the beam correcting force.

If an impurity error exists opposite a blank holder it is possible to remove the magnets from one position and place them in the area desired but they *must* be remagnetized after being placed in their new position.

When "hairpin" magnets are snapped on or off their holders they may lose some of their magnetism. If this occurs they should be re-magnetized. This should be done with the hairpins on their holders as follows: Set the "hairpins" so that they are in a horizontal position with the open ends in opposite directions. Rub one pole of a bar magnet across the two upper ends of the "hairpins" and the other pole of the bar magnet across the two lower ends.

Kinescope Color Temperature Adjustment

The kinescope color temperature refers to the caste of white or gray produced in the raster and *not* to the brightness level. The proper color temperature of a 21CYP22 tricolor kinescope raster is referred to as "8200° Kelvin." This appears gray, or white. A bluish-white or greenish-white raster indicates that the color temperature is too high, a pinkish-white raster is an indication of too low a color temperature.

A condition where the receiver is adjusted to too high a color temperature will result in a loss of red in the picture detail and will result in the inability to obtain good flesh tone reproduction when observing a color picture.

Too low a color temperature will result in loss of blue, green, or cyan colors in the picture with objects assuming a generally reddish-brown caste.

In order to obtain satisfactory performance from the kinescope, in both black-and-white and color operation, it is essential that there be no color temperature shift as the intensity of light output from the kinescope is varied through its useful range. The high-lights and low-lights in a black-and-white picture should retain a neutral shade of gray.

The procedure for proper kinescope color temperature adjustments is as follows:

The object of this procedure is to obtain the brightest picture possible, while maintaining proper tracking of the kinescope at all brightness levels. This condition is dependent upon having one (or more, as explained below) of the kinescope screen controls set to their maximum positions. Figure 60 shows the location of the screen and background controls.

1. Pre-set the SCREEN controls maximum clockwise and the BACKGROUND controls maximum counter-clockwise. Turn the BRIGHTNESS and CONTRAST controls fully counter-clockwise and tune-in station signal. Use a program which displays the full range of contrast from highlights to lowlights.

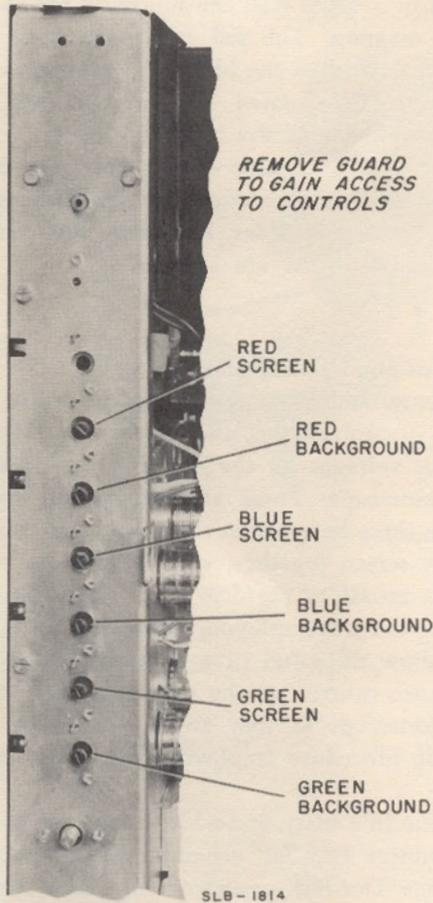

Fig. 60—Location of screen and background controls.

2. Advance the CONTRAST control to obtain a picture just slightly below normal brightness level. If the picture appears too dim at above setting advance the BRIGHTNESS control slightly. *Be careful not to advance brightness too close to overload.*

3. Adjust the RED, GREEN and BLUE BACKGROUND controls to produce white in the highlight areas of the picture. (Color temperature of 8200° Kelvin.)

4. The SCREEN control (or controls) which should remain at maximum control setting is determined as follows:

Adjust the BRIGHTNESS and CONTRAST controls to produce a low brightness level picture and observe the lowlight areas (dark objects) of the picture. Some color will prevail in the lowlight areas. Depending upon which color is evident proceed as outlined below to determine which screen will be set at maximum.

A. YELLOW IN LOW LIGHT AREAS—This condition indicates that the BLUE SCREEN control should remain at maximum setting.

B. CYAN IN LOWLIGHT AREAS—This condition indicates that the RED SCREEN control should remain at maximum setting.

C. MAGENTA IN LOWLIGHT AREAS—This condition indicates that the GREEN SCREEN control should remain at maximum.

D. RED, GREEN OR BLUE IN LOWLIGHT AREAS—This condition indicates that the screen, of whichever of these colors appears, is set too high and must be reduced from maximum. Turn this SCREEN control down *slowly*.

One of the following conditions will then occur.

a. The picture will become gray in the lowlight areas. If this occurs the remaining two SCREEN controls should remain at maximum setting and the corresponding BACKGROUND control for the SCREEN CONTROL that was turned down should be adjusted to produce white in the highlight areas. The kinescope should track at all brightness levels. Recheck at low level and if necessary retouch slightly the SCREEN control that was previously turned down to obtain gray in the lowlights.

b. The picture will become yellow in the lowlight areas. This condition corresponds to A. above and indicates the BLUE SCREEN control should remain at maximum.

c. The picture will become cyan in the lowlight areas. This condition corresponds to B. above and indicates the RED SCREEN control should remain at maximum.

d. The picture will become magenta in the lowlight areas. This condition corresponds to C. above and indicates the GREEN SCREEN control should remain at maximum.

5. At this point the kinescope color temperature either tracks or the SCREEN control that must be maintained at maximum is determined. *From this point on do not adjust either the SCREEN or BACKGROUND control for the color which remains at maximum SCREEN control setting. This is important.*

6. If adjustment is required, set the brightness to a low level and adjust the two remaining SCREEN controls to produce a gray picture in the lowlight areas.

7. Advance the BRIGHTNESS control to obtain normal brightness level and adjust the two remaining BACKGROUND controls for white in the highlight areas.

8. Check at all brightness levels for proper tracking. It may be necessary to retouch slightly the two SCREEN controls at lowlights and the two BACKGROUND Controls at highlights, remembering *not to adjust* either the SCREEN control or BACKGROUND control of the color previously determined to remain at maximum screen setting.

CONVERGENCE ADJUSTMENTS

Center Convergence

Observe a black-and-white picture on the screen of the kinescope. If objectionable color fringing exists, convergence adjustments are required. When color fringing is uniform throughout the area of the kinescope screen, center convergence adjustments may be all that are required. However, first check the position of the convergence yoke and the lateral beam positioning magnet. These assemblies, shown in figure 61, will cause color fringing if they have been shifted from their proper positions.

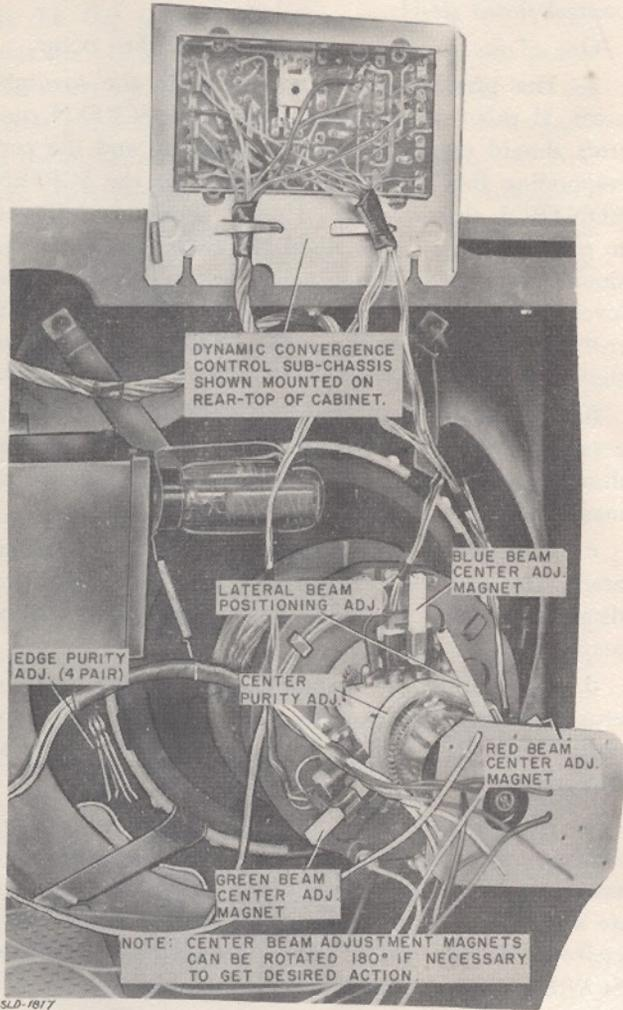

Fig. 61—Location of convergence adjustments.

Center convergence refers to the converging of the red, green and blue kinescope beams in the center of the screen. The procedure for center convergence is as follows:

1. Connect a Dot-Bar generator to the receiver antenna terminals or if preferred, to the 2nd Video Amplifier tube with the aid of the RCA WG-306A Adapter.
2. Adjust the receiver BRIGHTNESS and CONTRAST controls and the Dot-Bar generator output for a clear dot pattern on the face of the kinescope.
3. Adjust the RED, GREEN and BLUE center convergence magnets, which are slide-movement PM mag-

net adjustments on the convergence yoke assembly, and Lateral Beam Positioning Magnet until one group of red, green and blue dots in the center of the picture converge to a white dot. See figure 61 for the location of these magnets. The red and green dots should be converged first, then the blue. The convergence control magnets may be rotated 180° if necessary to attain desired movement of the beams.

Check the convergence of the dot trios throughout the screen area. If objectionable color fringing exists at the top, bottom, or sides, horizontal and vertical convergence adjustments are required.

Horizontal and Vertical Convergence

Horizontal and Vertical convergence refers to the adjustment of controls that affect the application of sweep correction voltages on the red, blue and green beams of the kinescope. These adjustments are required to make the three beams scan the height and width of the kinescope screen together, without causing color fringing. It is easiest to perform these adjustments when a procedure is used employing dot-bar patterns that most readily show the effect of each horizontal and vertical convergence control on the red, green and blue beams of the kinescope as they sweep across the screen. A systematic procedure employing such patterns is given below:

1. Tune in a black-and-white picture on the receiver.
2. Connect Dot-Bar generator to the receiver.
3. Tune Dot-Bar generator for stable vertical and horizontal bars (crosshatch pattern). Adjust brightness and contrast controls on the receiver and the Dot-Bar generator output for a clear bar-pattern without station interference, but also make certain that the receiver is being synchronized by station sync. In order to obtain correct convergence, it is necessary to perform horizontal and vertical convergence adjustments while the receiver is being scanned at the station rate.

The convergence board assembly is designed to permit adjustments to be made from the front of the receiver. Loosen the two screws holding the board and slide the bracket to the left and remove. Fasten the bracket to the two screws provided on the top rear rail of the cabinet with the controls facing the front. Slots are provided in the bottom of the bracket to facilitate mounting in this position.

Vertical convergence should be performed before attempting horizontal convergence.

Vertical Convergence Adjustments

Refer to figures 62 and 63 for control locations.

1. Adjust the dot-bar generator for a vertical bar pattern.
2. Using the blue vertical bar at the center of the screen as reference, adjust the RED and GREEN "TILT" controls to produce equal displacement of the red and green bars at the top and bottom of the kinescope screen. See figure 64A.

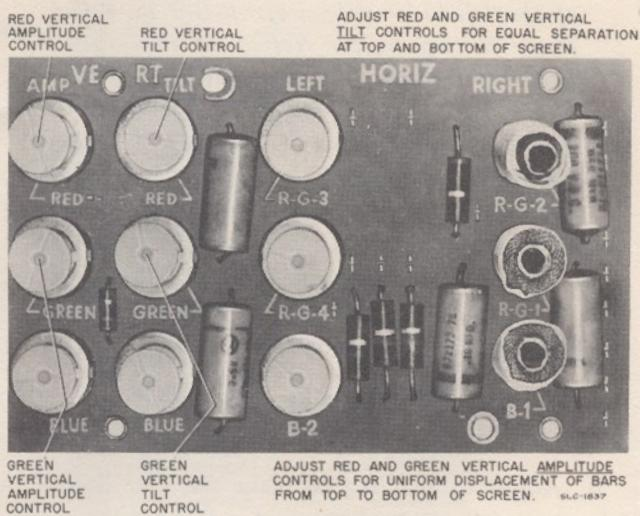

Fig. 62—Red and green vertical convergence controls.

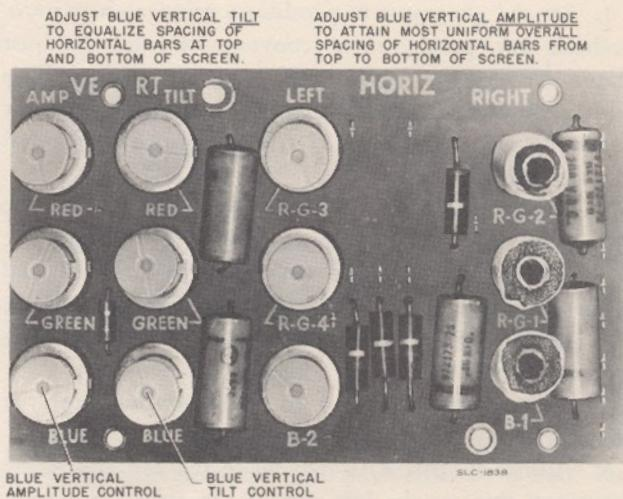

Fig. 63—Blue vertical convergence controls.

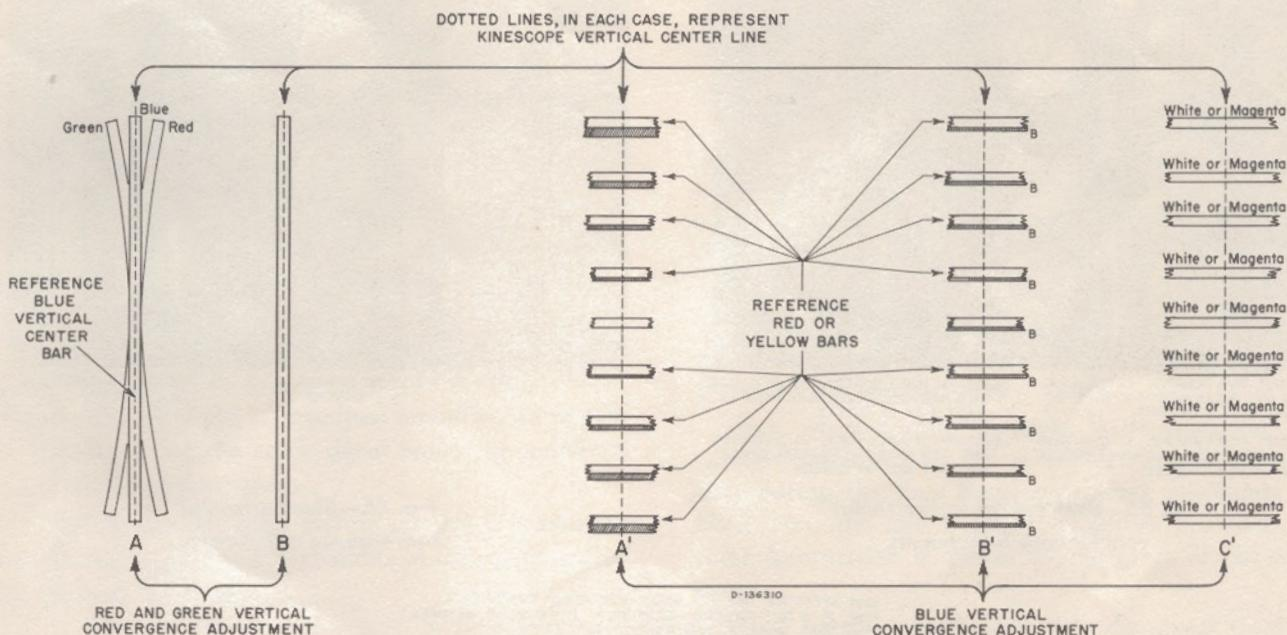

Fig. 64—Vertical convergence adjustment patterns.

3. Adjust the RED and GREEN "VERTICAL AMPLITUDE" controls to parallel the red and green bars with the blue bar down the center of the screen. Retouch the RED and GREEN "VERTICAL AMPLITUDE" and "TILT" controls as required to make the red, green and blue bars parallel to each other or, converge. If necessary, readjust the center convergence magnets to superimpose the parallel lines, making a white line from top to bottom. See figure 64B.

4. Adjust the dot-bar generator for horizontal bars. (For clarity in adjustment, short the green grid to ground through a 100K resistor, move blue bar downward with "blue" center convergence magnet and use red horizontal bars as reference.)

5. Adjust the BLUE "VERTICAL AMPLITUDE" and "TILT" controls for equal separation of the pairs of blue and red bars from the top to the bottom of the kinescope screen, concentrating along the vertical center line of the screen. (Use the BLUE "TILT" control to equalize spacing at the top and bottom, as shown in figure 64A' and the amplitude to attain most uniform overall spacing as shown in figure 64B'.)

6. Move the blue bar upward and superimpose the associating pairs of bars as illustrated in figure 64C'.

7. Remove 100K resistor shorting the green grid to ground, if employed during adjustment.

Horizontal Convergence Adjustments

See figures 65 and 66 for control locations.

1. Set the generator to produce a crosshatch pattern. Recheck for good center convergence and readjust center convergence magnets if required. (Shunt Blue grid to ground if desired, through a 100K resistor for clarity during adjustment of red and green horizontal convergence.)

2. Adjust coil R-G-1 to make vertical lines at the right side converge. See figure 68A.

3. Adjust coil R-G-2 to make horizontal red and green lines at the right side converge. See figure 68B.

4. Retouch R-G-1 for convergence of vertical lines at the right side.

5. Adjust control R-G-3 to make vertical lines at the left side converge. See figure 68C.

6. Adjust control R-G-4 to make the red and green horizontal lines at the left side of the screen converge. See figure 68D.

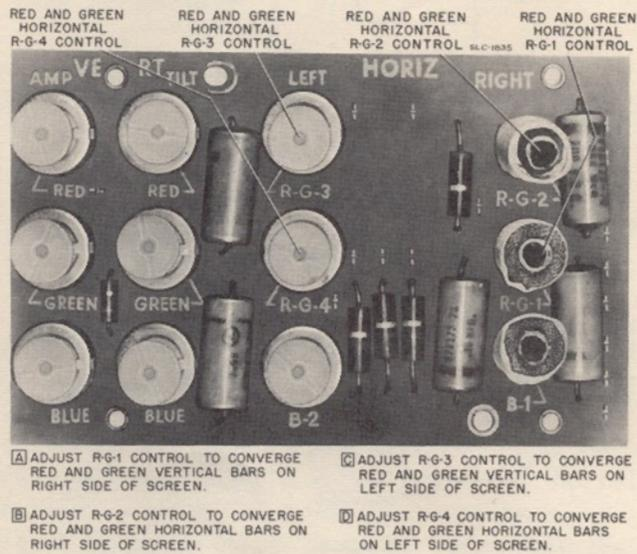

Fig. 65—Red and green horizontal convergence adjustments.

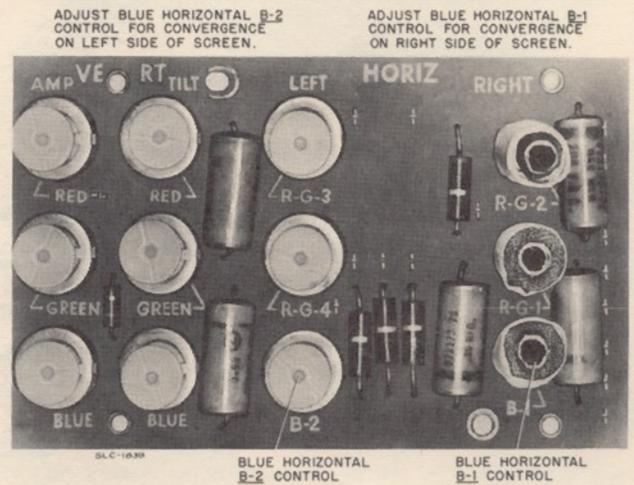
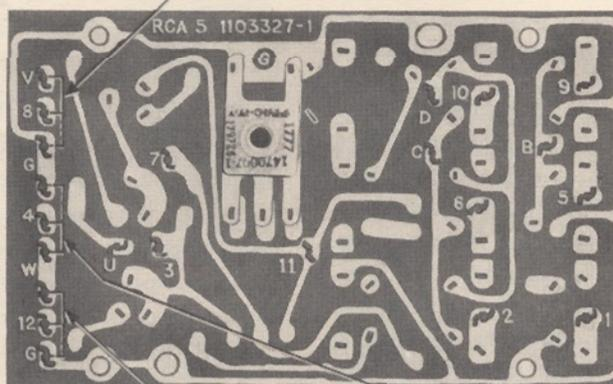

Fig. 66—Blue horizontal convergence adjustments.

LINK AFFECTING RED AND GREEN HORIZONTAL CONVERGENCE (USE IN B TO V POSITION OR 8 TO G POSITION AS REQUIRED FOR BEST RESULTS. HAS MOST EFFECT ON RIGHT SIDE OF SCREEN.)



LINK AFFECTING RED AND GREEN HORIZONTAL CONVERGENCE (USE IN 12 TO W POSITION OR 12 TO G POSITION AS REQUIRED FOR BEST RESULTS. HAS MOST EFFECT ON LEFT SIDE OF SCREEN)

LINK AFFECTING BLUE HORIZONTAL CONVERGENCE (USE IN W TO 4 POSITION OR 4 TO G POSITION AS REQUIRED FOR BEST CONVERGENCE RESULTS)

Fig. 67—Positioning of range extending links.

NOTE

If it was not possible to achieve convergence at the left side with either R-G-3 or R-G-4, move the clips on the rear of the convergence board as follows: — Move the clip between terminals V and 8, to 8 and G. Move the clip between W and 12, to 12 and G. See figure 67. Repeat adjustments of R-G-3 and R-G-4 and sufficient range will be obtained to converge in each case.

7. After adjusting R-G-4 repeat adjustment of R-G-3 to compensate for any interaction.

8. Adjust coil B-1 to make the blue line at the right center fall on the converged red and green lines.

9. Adjust control B-2 to make the blue line at the left center fall on the converged red and green lines.

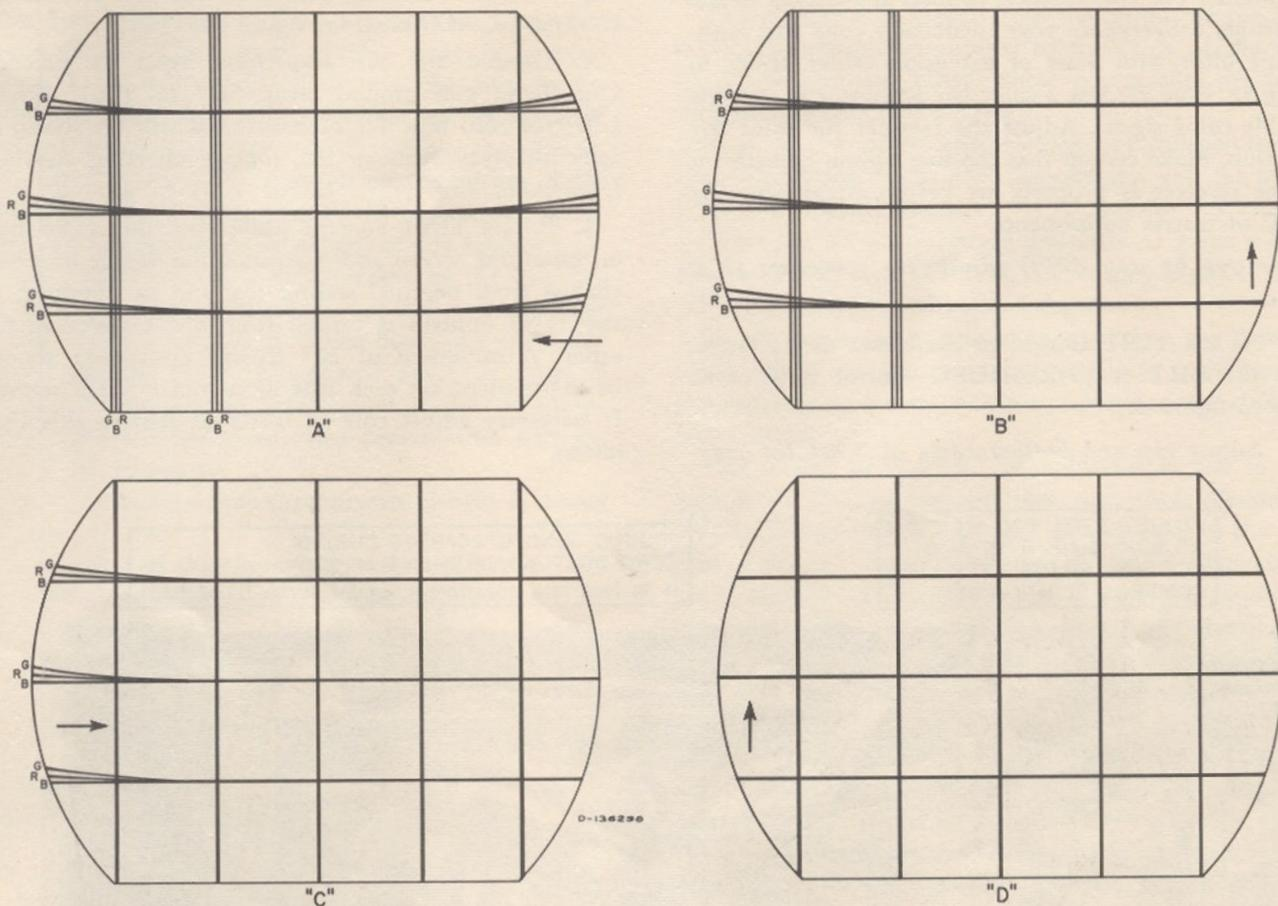

Fig. 68—Horizontal convergence adjustment patterns.

Final Center Convergence Adjustments

1. Set dot-bar generator for dot pattern.
2. Adjust RED, GREEN and BLUE center convergence magnets and Lateral Beam Positioning adjustment to converge the dots in center of kinescope screen.

After completing convergence adjustments, tune in a normal black-and-white picture. Check for fringing by observing the picture from a distance of approximately six feet from the screen. If fringing is objectionable, repeat the horizontal and vertical convergence procedure outlined above. If the picture reveals no objectionable fringing, the convergence procedure is completed.

To facilitate center convergence, horizontal and vertical convergence and purity adjustments, it is advantageous to be able to cut off the red, green and blue kinescope beams individually during the course of the convergence procedure. This may be done most readily with a control switch which provides a means of connecting a 100K resistor from each of the kinescope control grids to ground, at will.

The kinescope screen controls may be used to cut off the beams if desired, however this makes it necessary to perform color temperature adjustments when convergence or purity adjustments are completed.

To attain optimum performance make final kinescope color temperature and convergence adjustments with the receiver functioning at normal operating temperature.

AFPC ADJUSTMENTS

To properly align the AFPC circuits of the 800 series color receivers it is necessary to remove the chassis from the cabinet. For convenience, connect the chassis to the kinescope, convergence yoke, deflection yoke and high-voltage ultor with a set of extension cables. Refer to figure 52, page 27. Use a color bar generator to provide a stable color signal. Adjust the receiver for color bar reception. Make certain that the fine tuning adjustment on the receiver is properly set before attempting any AFPC or matrix adjustments.

The step by step AFPC adjustment procedure is as follows:

1. Set the TINT control to the center of its range. Turn the KILLER THRESHOLD control fully c.c.w. Refer to figure 47.
2. Adjust *top* and *bottom* cores of T704 for maximum DC at pin #7 of killer Detector V706C, see figure 69. (Use a DC isolating probe in series with V.T.V.M.)

imum DC at pin #7 of killer Detector V706C, see figure 69. (Use a DC isolating probe in series with V.T.V.M.)

3. Adjust T703 core for maximum DC at junction C712/R716, ACC buss, see figure 69.
4. Ground the reactance tube input at junction C726/R743 and ground term. "D" of T701. Adjust L704 for zero beat (color bars stand still on screen or drift slowly). Remove the jumper shorting junction C726/R743 and term. "D" of T701 to ground.
5. Rotate TINT control while observing color bars on kinescope screen and determine the degree of phase change from nominal setting that can be obtained, as the TINT control is turned from one extreme to the other. A minimum of 30° change (one bar) should be experienced on each side of nominal phase setting. If necessary adjust core of T703 to achieve this condition.

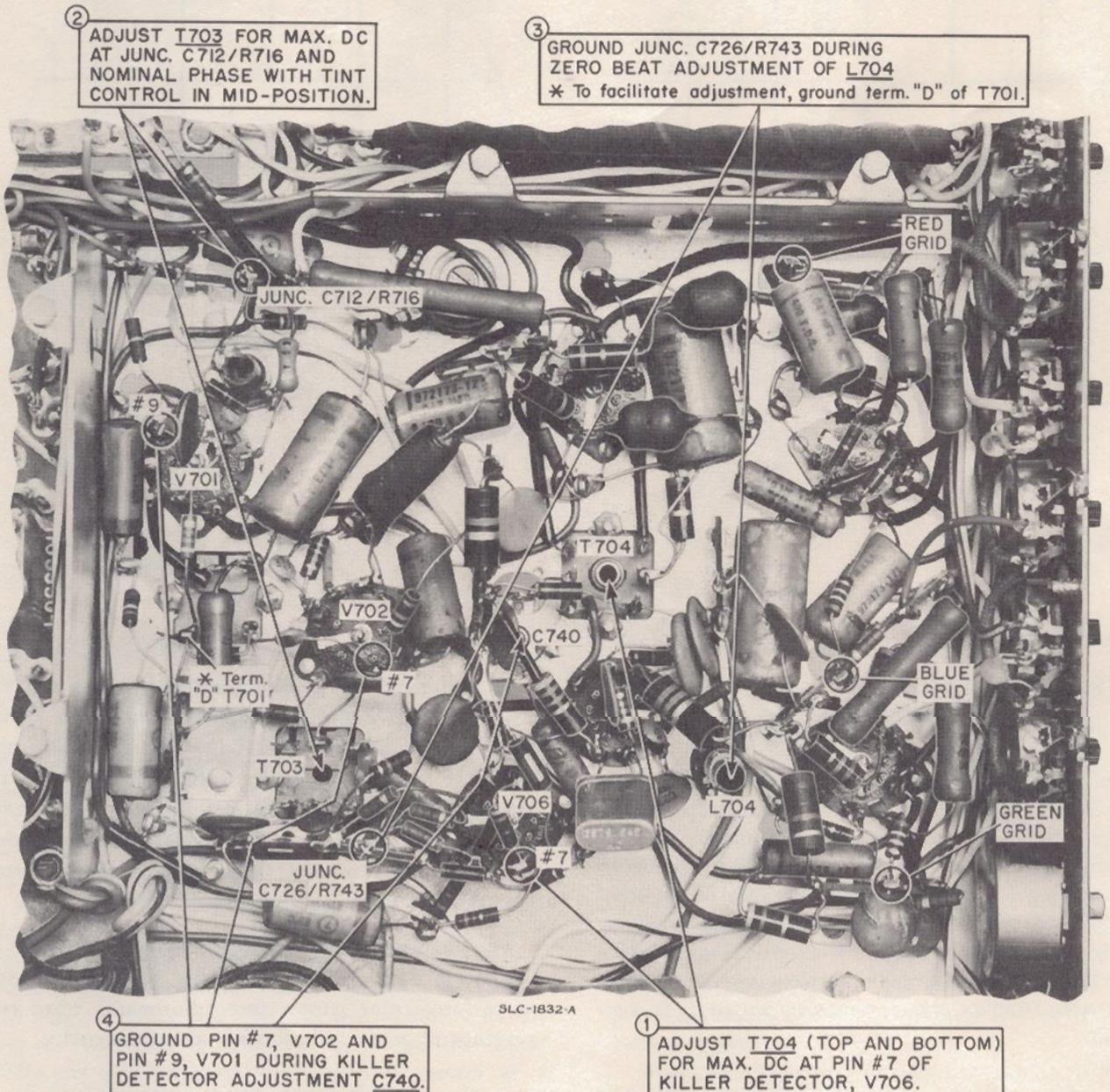

2 ADJUST T703 FOR MAX. DC AT JUNC. C712/R716 AND NOMINAL PHASE WITH TINT CONTROL IN MID-POSITION.

3 GROUND JUNC. C726/R743 DURING ZERO BEAT ADJUSTMENT OF L704
* To facilitate adjustment, ground term. "D" of T701.

4 GROUND PIN #7, V702 AND PIN #9, V701 DURING KILLER DETECTOR ADJUSTMENT C740.

1 ADJUST T704 (TOP AND BOTTOM) FOR MAX. DC AT PIN #7 OF KILLER DETECTOR, V706.

Fig. 69—AFPC and Killer detector adjustment points, CTC7 chassis.

(Nominal phase setting is the point at which the TINT control produces the proper colors in the picture, assuming the demodulators are phased properly. Proper adjustment positions this point in the center of the mechanical range of the TINT control.)

Nominal phase can be detected by observing the red bars of the color bar pattern (blue and green grids shunted to ground through 100K resistors). At nominal phase the sixth bar should be the same brightness as the background.

6. Observe the red bars on kinescope screen. (Blue and green grids shunted to ground through 100K resistors) and set the TINT control for nominal phase.

7. Observe the blue bars on kinescope screen (red and green grids shunted to ground through 100K resistor), and adjust TOP core of T704 so that the third and ninth bars are the same brightness as the background.

Killer Detector Adjustment

1. Short the grid of the burst amplifier, pin #7 of V702, and the grid of the killer, pin #9 of V701 to ground using short jumpers. Refer to figure 69.

2. Adjust CW drive trimmer C740 for zero volts at pin #7 of killer detector, V706. Remove shorting jumpers after adjustment.

3. Observe the blue bars on kinescope screen (red and green grids shunted to ground through 100K resistor), and if necessary, adjust TOP core of T704 so that the third and ninth bars are the same brightness as the background.

4. If adjustment was required in step 3 repeat steps 1 and 2.

DEMODULATOR PHASING ADJUSTMENTS

1. Set the TINT control to the center of its range and the color threshold control fully c.c.w. Refer to figure 47.

2. Insert a 9-pin adapter (which has the connection to pin #1 opened) into the color demodulator socket V703. Insert the demodulator tube into the adapter. This will provide for "X" axis demodulation only.

3. Shunt the green and blue kinescope grids, see figure 69A, to ground through 100K resistors, and adjust the receiver for a red color bar pattern.

4. Observe the red bar pattern and *with the TINT control in the center of its range*, adjust T703 so that the sixth bar is slightly brighter than the background and the seventh bar is slightly darker than the background. See figure 69A for adjustment locations.

5. Rotate the TINT control from one end of its range to the other. At one extreme the sixth bar should go darker than the background and at the other extreme the seventh bar should go brighter than the background. Touch up the adjustment of T703, if necessary, to attain this condition.

6. Set the TINT control to mid-position where the

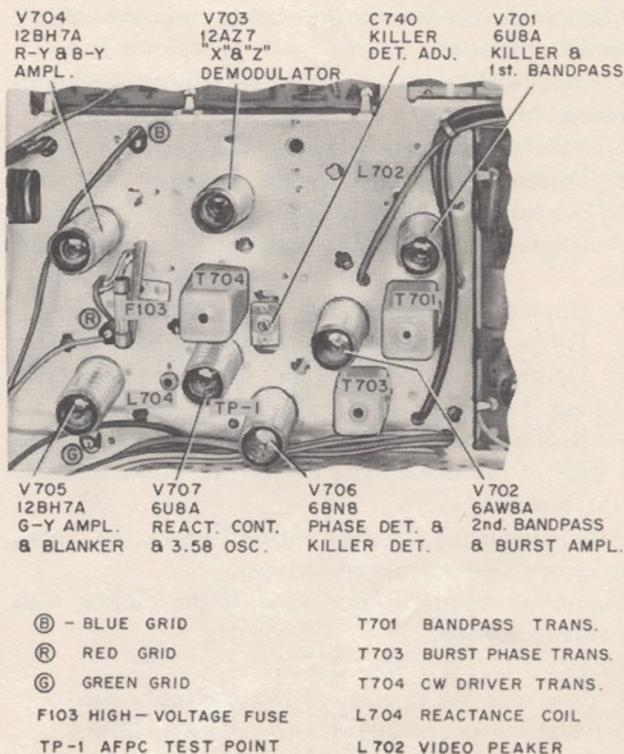

Fig. 69A—Demodulator phasing adjustment locations. R, B and G are the kinescope grid test points.

sixth bar is slightly brighter than the background and the seventh bar is slightly darker than the background.

7. Remove the tube socket adapter and replace the demodulator tube in its socket. Remove the 100K resistor shorting the blue grid to ground and use it to short the red grid to ground providing for a pattern of blue bars. Refer to figure 69A for grid connection locations.

8. Adjust the top core of T704 to make the third and ninth bars (blue) at the same brightness level as the background. Refer to figure 69A for adjustment location.

9. Move the shorting resistor from the green kinescope grid to the blue kinescope grid and check for correct G-Y output. The first and seventh bars should be the same brightness level as the background. Move the shorting resistor from the red kinescope grid to the green kinescope grid and check for correct R-Y output. The sixth bar should be at the same brightness level as the background. Reset the killer threshold control, using no signal, so that color just disappears from the noise pattern on the kinescope.

CHASSIS REMOVAL

The CTC7 chassis used in the 800 Series receivers are comparatively light in weight. The tuner unit is secured to the chassis. To remove the chassis from the cabinet proceed as follows:

1. Take off the control knobs by pulling the knobs outward.
2. Take off the rear panel of the receiver.
3. Disconnect the ultor anode connector inside the H.V. compartment. Refer to figure 53.
4. Unplug the deflection yoke wires and speaker wires.
5. Unplug the convergence yoke cable.
6. *Carefully* disconnect the kinescope socket.
7. On models using purity coil, disconnect the purity coil plug, located on forward apron of chassis.
8. Remove the three chassis bolts (two underneath the shelf of the cabinet and one on the upper left side of the cabinet).

After completing the steps outlined above, the chassis may be withdrawn from the cabinet.

Figure 70 shows the rear view of the cabinet with the chassis removed.

CAUTION:

Take care not to damage the horizontal control knob extension when withdrawing chassis from cabinet.

To replace the chassis in the cabinet reverse the procedure outlined above.

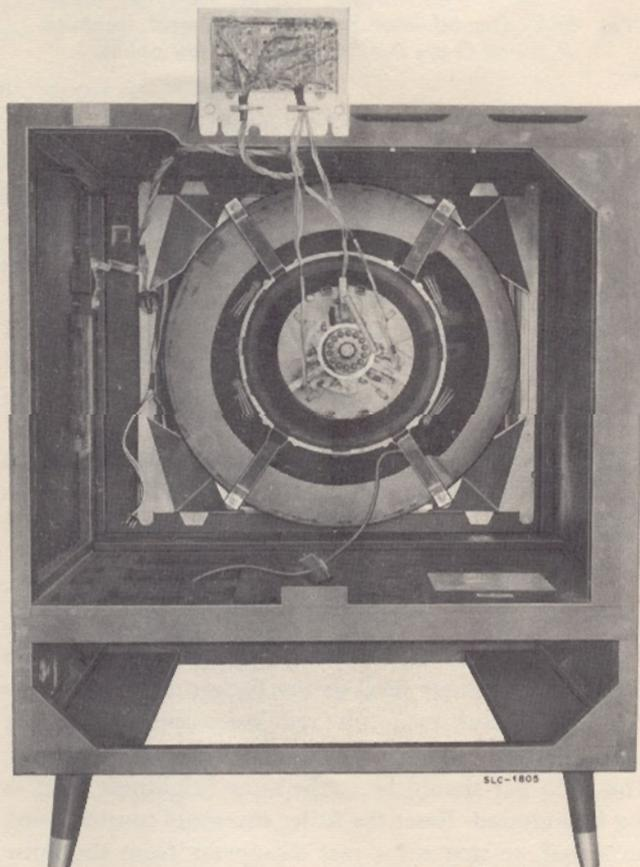

Fig. 70—Rear view—chassis removed from cabinet

REMOVAL OF KINESCOPE

Before attempting to remove the kinescope from the cabinet, remove the receiver chassis as outlined above, then remove the kinescope as follows:

1. Slide the lateral-beam positioning magnet, the purity magnet, and the convergence yoke off the neck of the kinescope.
2. Remove the convergence control sub-chassis from the rear of the cabinet and mount on cabinet as shown in figure 70.
3. Loosen the deflection yoke set-screw, refer to figure 55, and slide yoke off the neck of the kinescope.
4. Carefully lay cabinet face down on a protective surface.
5. Remove the four nuts holding the kinescope mounting brackets to the front mask assembly. See figure 71.

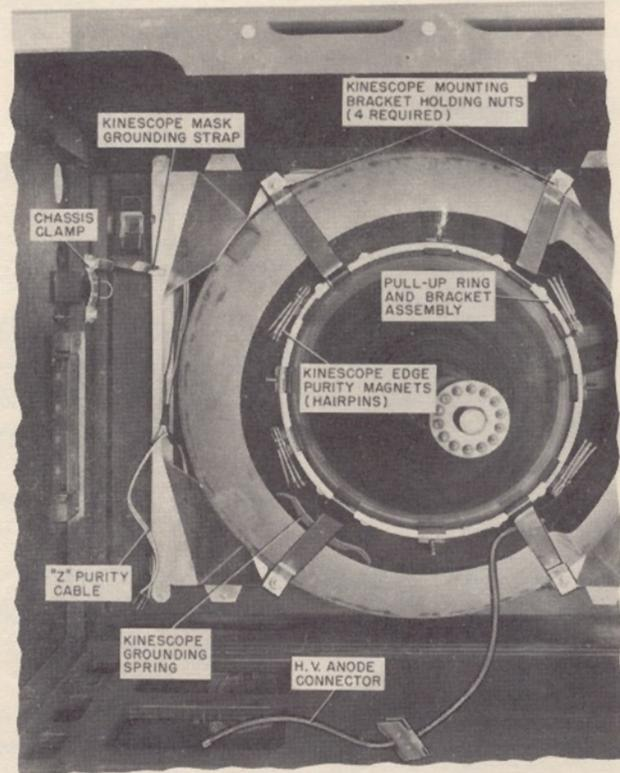

Fig. 71—Kinescope mounting.

6. Lift off the pull-up ring and strap assembly.
7. Remove the metal shield (not on metal cabinets) and the H.V. insulator. See figure 72.
8. Disconnect the anode lead and the resistor and spring assembly.
9. Grasp the bell of the kinescope and lift the kinescope up and out of the kinescope mounting brackets.
10. Remove the wrap-around protective liner from the front edge of kinescope. See figure 73.

KINESCOPE INSTALLATION

1. Connect the anode lead and the spring and resistor as shown in figure 73.
2. Set the kinescope on its face on a protective pad and face the blue gun toward you (kinescope base pin #12 facing you).

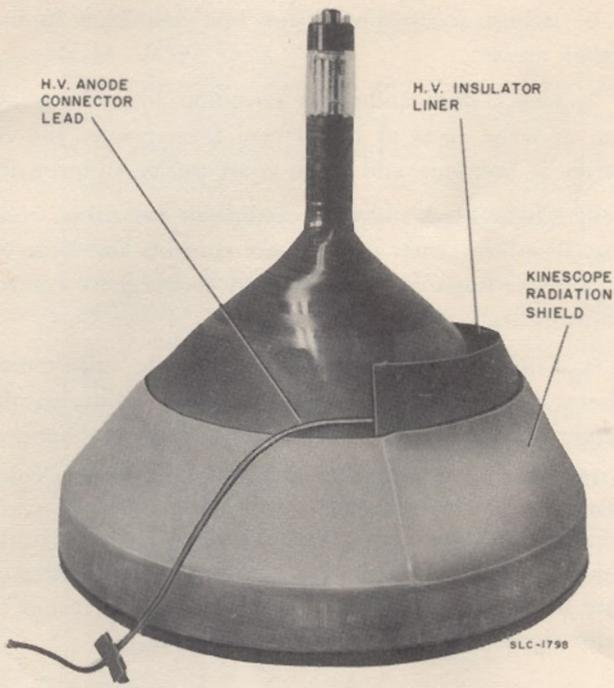

Fig. 72—Kinescope with shield, insulator and H. V. lead.

3. Place the end of the front wrap-around protective liner against the edge of the kinescope at the glass bump, located at the two o'clock position on the kinescope, and wrap clockwise around the front bell, overlapping at the end, and secure with tape provided.

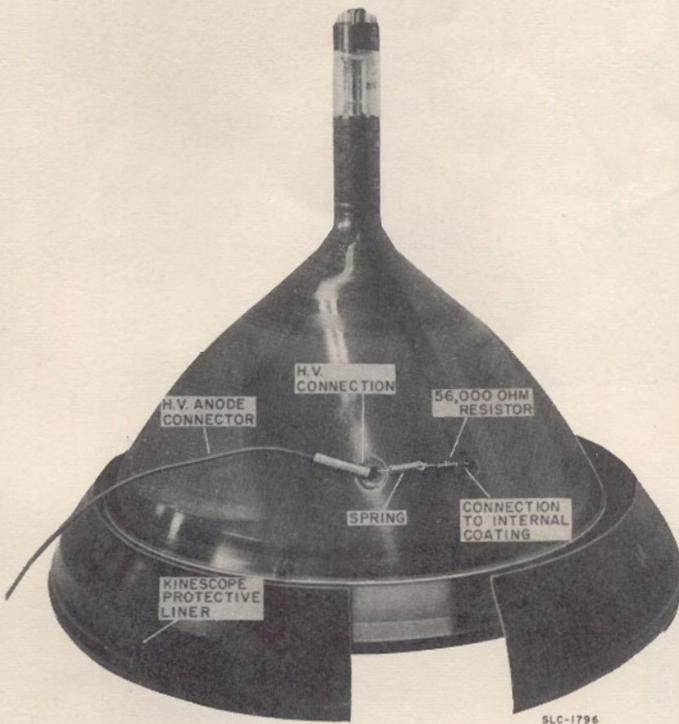

Fig. 73—Installation of H. V. lead and protective liner.

4. Carefully place the kinescope into the kinescope mounting bracket, shown in figure 74, with the blue gun facing the top of the cabinet. The cushions on the front edge of the wrap around shield should rest in the mounting bracket at the top and bottom of the kinescope.

5. Place the anode lead insulator over the kinescope, positioned so that the resistor, spring and anode lead fall under the ridge in the insulator, with the lead emerging from the left side, as shown in figure 72.

6. Replace the radiation shield (except on metal cabinets) in position as shown in figure 72.

7. Install the pull-up ring and strap assembly in position, as shown in figure 71, and fasten loosely. Position the anode lead insulator so that both ends are under the straps and tighten the four nuts securing the pull-up ring and strap assembly to the kinescope mounting bracket.

8. Set the receiver cabinet in an upright position and place the deflection yoke, convergence yoke, purity magnet and lateral-beam positioning magnet in their proper positions. Refer to figure 55.

The convergence coil assembly should be mounted with the leads toward the kinescope bell, and its magnet pole pieces over the pole pieces at the front end of the kinescope guns. Refer to figure 56. The opening between the two magnets should be over the opening between the pole pieces and the blue coil must be positioned over the blue gun. The proper coil may be determined by the color of its wires.

The purity magnet should be placed on the kinescope neck with the supporting tabs toward the bell of the kinescope and about $\frac{1}{4}$ inch behind the convergence coil and magnet assembly. The lateral-beam positioning magnet should be placed in the position shown in figure 56.

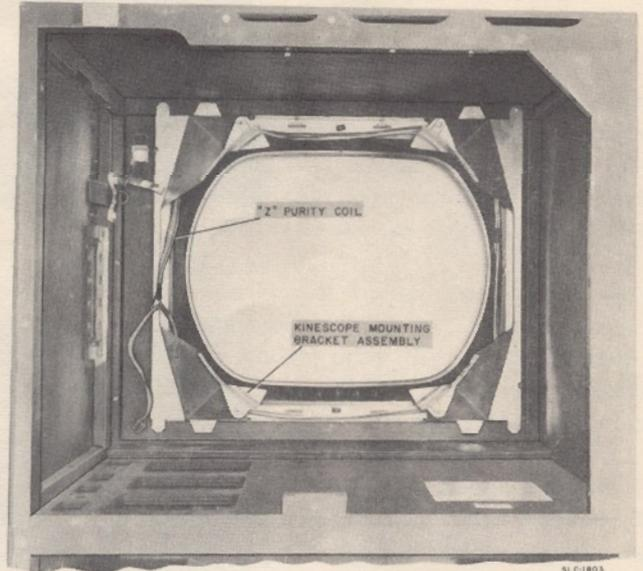

Fig. 74—Kinescope mounting bracket.

RECEIVER SET-UP CHECK LIST

Connect the antenna transmission line to the receiver antenna terminals.

Plug the power cord into the 117V. AC outlet and turn the receiver "ON." The receiver should operate normally. However, a check of the following adjustments should be made.

1. Check for normal operation of horizontal (freq.) control. The picture should hold sync for a minimum of $\frac{5}{8}$ of a turn of the control.
2. Check centering of picture. Adjustment is made with the centering controls on the rear apron.
3. Check height and vertical linearity, reset controls, where required, for one inch overscan.
4. Check R-F oscillator adjustment on all channels. Readjust, if necessary, starting at the highest frequency channel, and proceeding to the lowest.
5. Where FM interference is encountered, for minimum interference in the picture, adjust the FM trap.

6. Adjust focus control for best definition in fine detail areas.

7. Check black-and-white reception for color shading in large areas of the screen. Demagnetize the receiver if necessary and make color purity adjustments.

8. Check black-and-white reception for color fringing. Re-adjust center convergence controls and if necessary, make horizontal and vertical convergence control adjustments.

9. Check kinescope color temperature adjustment. Raster must remain a neutral gray, or white, as the brightness control is varied through its useful range.

10. Check for reception of color signal. Use a color program or a transmitted color stripe signal if available in area where receiver is installed. This will also check antenna for color reception. A color bar generator may be employed but this will not insure reception of color signal through the antenna system.

FUSE DATA

Figure 75 shows the location and function of each of the three fuses in the CTC7 chassis.

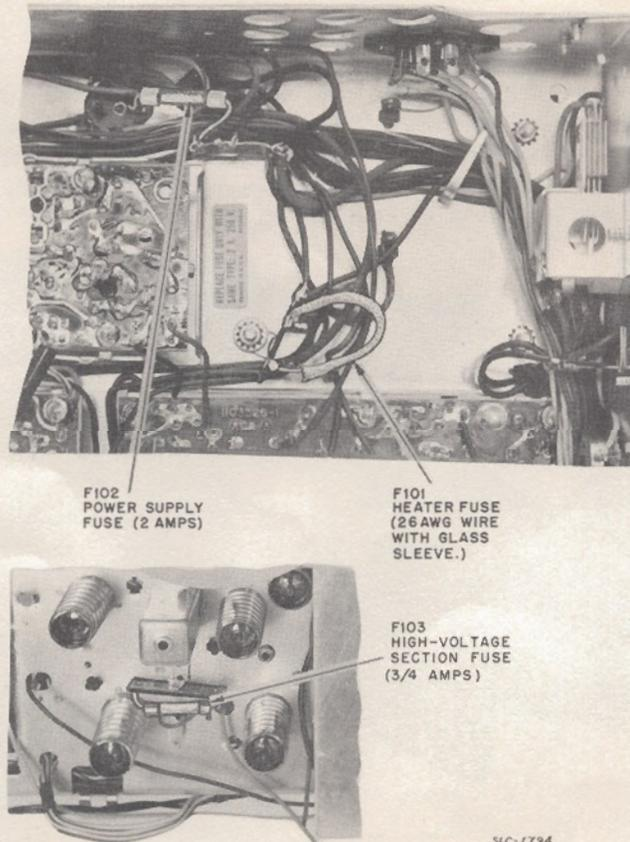

Fig. 75—Fuse locations—CTC7 chassis.

ANTENNAS

ANTENNA CONSIDERATIONS

The majority of antennas which are now being used for black-and-white reception will function satisfactorily for color reception in most locations but the technician must always bear in mind that some existing antenna installations providing for good black-and-white reception may not necessarily provide good color reception on all channels.

To insure good color pictures on a color receiver it is very important that the technician give proper attention to the electrical characteristics of the antenna intended for use in conjunction with the receiver.

ANTENNA SYSTEM RESPONSE

One condition which will cause poor color reception and yet may not have a very great effect on black-and-white pictures is a steep slope in the signal gain curve across a given channel.

An antenna intended for use in the reception of color signal information should have a reasonably flat frequency response over the channels on which color signals are to be received. (For color use, a 2 db maximum gain variation within the individual channel spectrum has been determined to be a reasonable tolerance in antenna response.)

In addition to gain characteristics of the antenna itself, it is important to keep in mind that a poor match between the transmission line and the antenna or receiver input can result in a large variation in the signal gain curve across a given channel. As a matter of fact it is important to keep in mind that anything which affects the response of the antenna system, or the RF-IF response of the receiver may also cause poor color reception. For example:

1. If RF traps or stubs are connected to the transmission line, they are very likely to alter the relative response for the picture carrier and color-subcarrier signals on one or more channels.

2. If two or more receivers are connected directly to the transmission line, without suitable isolation and matching, the relative response for the two carriers will be altered on some channels. The use of inductive or transformer-type multiple-set couplers is not recommended for color reception. In locations where the signal strength is sufficient, it is advisable to use resistive-type couplers such as shown in fig. 76. In weak signal areas it is advisable to use suitable antenna-distribution amplifiers.

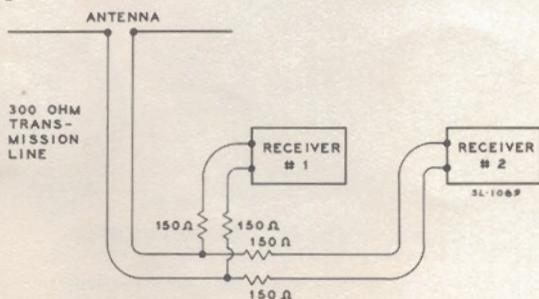

Fig. 76—Method of coupling two receivers to one antenna.

3. If the RF and IF amplifiers in the receiver are misaligned, the gain ratios for the picture-carrier and color-subcarrier signals may be altered. The normal over-all RF-IF response in recent RCA Victor color receivers is shown in Fig. 77. Note that the picture carrier and the color subcarrier fall at the 50% response point on their respective slopes. If the amplifiers are misaligned in such a way that the color subcarrier falls at 10%, for example, the gain for the color subcarrier is reduced to 1/5th.

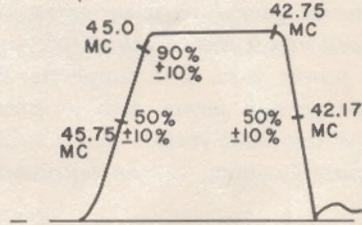

Fig. 77—Overall RF-IF response in color receivers.

MULTIPATH SIGNALS

For optimum color signal reception in locations where multipath signals (reflections) are a problem, the antenna should have a narrow directivity pattern and *good front-to-back ratio* on the desired channels.

Even though the response of the antenna may be flat, and the RF-IF alignment correct, reflections (multipath reception) may reduce the strength of the color subcarrier signal with respect to the picture-carrier signal, or vice versa. This condition may not be accompanied by the presence of noticeable ghosts in the picture, because "close-in" ghosts merge with the direct-signal picture and can not be seen separately. The reflected picture-carrier signals may aid or oppose the picture-carrier or color subcarrier signals which are received directly from the station.

Additional factors which make multipath interference more detrimental to color pictures than monochrome pictures are:

1. The m-p ghosts will commonly be a different color than the background. For example, a green "ghost" on a face looks worse than a black "ghost."

2. Short delay m-p "ghosts" in a monochrome picture can be made less objectionable by "smearing." That is, the receiver may be detuned a little to reduce resolution and make the "ghosts" less apparent. The color receiver must be kept properly tuned.

3. Many monochrome receivers are narrow-band, hence short delay "ghosts" are not visible.

To minimize multipath reception the antenna should be oriented to attain optimum results for each station transmitting color signals.

Where the stations are in different directions, in areas subject to multi-path reception it is advisable to use an antenna rotor. The technician should always take advantage of every opportunity to note the effects of antenna orientation on color reception from each station at different locations in his area, until he is familiar with the effects.

ANTENNA GAIN

Antenna gain is a measure of the sensitivity of an antenna expressed in comparison to the sensitivity of a half-wave dipole at a given frequency. For example, suppose a half-wave dipole antenna at a given location and for a fixed received signal develops a signal voltage of 500 microvolts. Another more sensitive antenna, which develops 1000 microvolts under the same conditions, is said to have a voltage gain of 2 or a power gain of 4.

However, antenna gains are more often expressed in terms of decibels which can be calculated from either the voltage or power gain. For simplicity the table below shows voltage and power gain in terms of db gain. Reference to this table reveals that a voltage gain of 2, as in the example above, can be expressed as a db gain of 6.

Power Gain	Voltage Gain	Gain in db
1	1	0
2	1.41	3
3	1.73	4.8
4	2	6
5	2.24	7
6	2.45	7.8
7	2.65	8.5
8	2.82	9
9	3	9.5
10	3.16	10
20	4.47	13
50	7.07	17
100	10	20
400	20	26
1000	31.6	30
10,000	100	40

FRONT-TO-BACK RATIO

It is generally true that an antenna which has a good front-to-back ratio will have good gain characteristics—considering its size, number of elements, etc. However, the front-to-back ratio of an antenna is normally given as a measure of its ability to minimize or reject unwanted co-channel, adjacent channel, or other types of interference arriving at the antenna from the rear.

In many cases the important consideration is not only whether the antenna has high gain or good front-to-back ratio, but whether the antenna has good, deep nulls in the polar response in the direction from which the interfering signal is coming. The object, then, is to choose an antenna which will minimize response in the direction of the interfering source without sacrificing any needed forward gain. Polar patterns, by showing the response in all directions, provide the means for doing this. Note, too, that while a good null is extremely sharp, the major lobe—on most channels—is so broad as to allow at least a 60 degree latitude in orientation on the desired station. This leaves plenty of latitude for compromise orientation when it is desired to put an interfering signal in a "null." Obviously, the null must be located within approximately 30 degrees of the direction from which the interfering signal is originating. A good knowledge of the antenna polar pattern is essential, therefore, to do a good job on installations in critical reflection or interference areas.

ANTENNA CHARACTERISTICS

Figure 78 shows a dipole-and-reflector type antenna referred to as type A, suitable for reception of both color and black-and-white television signals in areas having sufficient signal strength and not subjected to multipath signal interference.

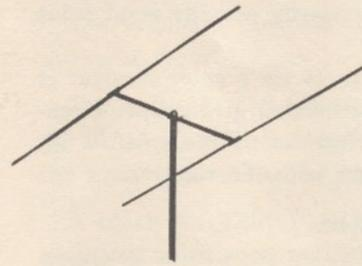

ANTENNA TYPE "A"

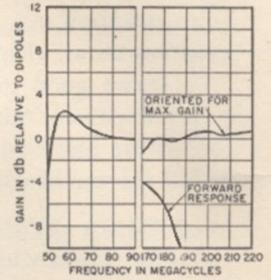

ANTENNA GAIN

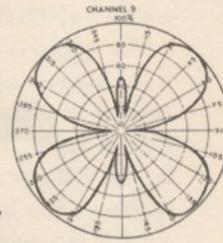
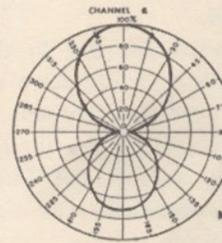
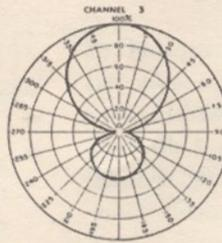

MSA-2717

POLAR RESPONSE PATTERNS

Fig. 78—Dipole and reflector antenna and directivity characteristics.

Properly installed dipole and conical type broadband antennas such as shown in figures 78 and 79 normally have adequate bandwidth to receive the full 6 mc. signal required for color television reception. However, their directional, gain characteristics and front-to-back ratio as shown in figures 78 and 79 are not suitable in areas subject to multipath or weak signal conditions.

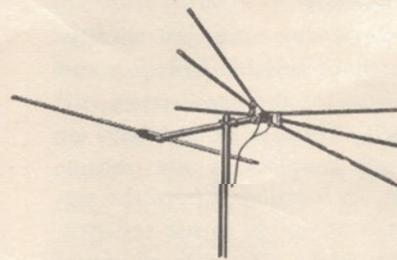

ANTENNA TYPE "B"

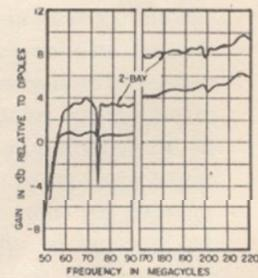

ANTENNA GAIN

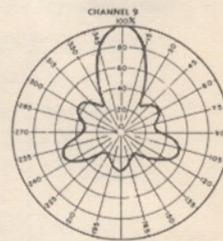
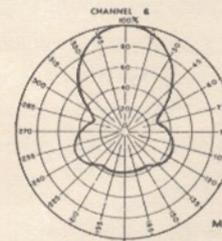
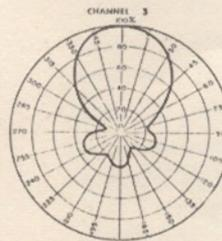

MSA-2718

POLAR RESPONSE PATTERNS

Fig. 79—Conical type antenna and directivity characteristics.

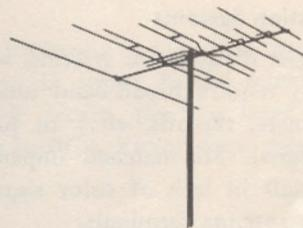

ANTENNA TYPE "C"

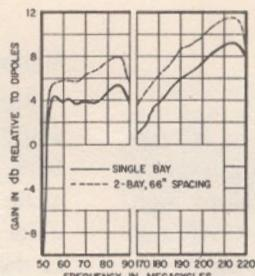

ANTENNA GAIN

Fig. 80—Antenna having high gain and good front-to-back ratio.

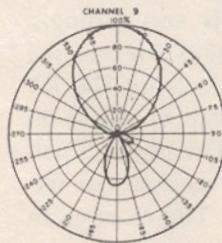
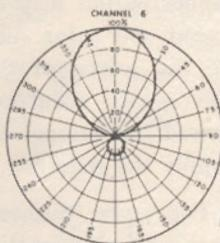
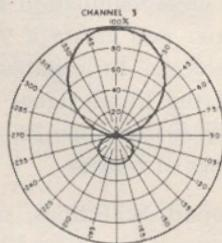

MSA-2711

POLAR RESPONSE PATTERNS

There are two general types of antennas that will greatly improve reception in troublesome areas. First, is one having very good signal gain characteristics and good directivity but not necessarily a good front-to-back ratio. It would be used where signal strength is low and where there are no bad reflected signals toward the back of the antenna. This type of an antenna is shown in figure 80 along with its polar characteristics and gain curves.

The second is one having good signal gain characteristics and excellent front-to-back ratio. Such an antenna does a very fine job in areas where there is good signal strength but bad multipath signal interference present. This type of antenna is shown in figure 81 along with its polar characteristics and gain curves.

By taking the proper care and precautions, there should be very few locations where satisfactory color cannot be received.

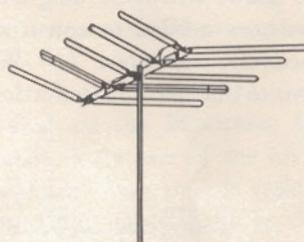

ANTENNA TYPE "D"

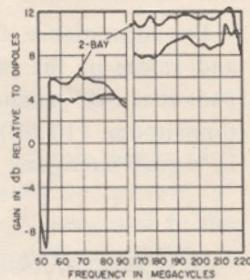

ANTENNA GAIN

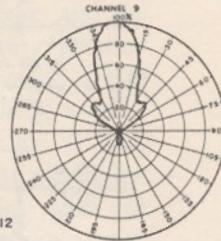
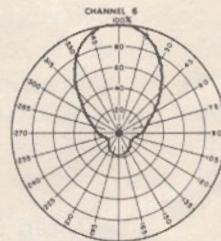
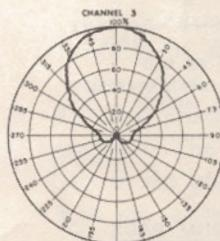

MSA-2712

POLAR RESPONSE PATTERNS

Fig. 81—Antenna suitable for use where multi-path reflections are a problem.

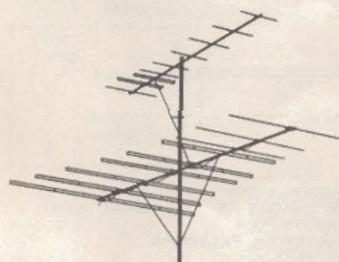

ANTENNA TYPE "E"

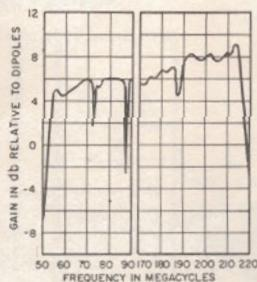

ANTENNA GAIN

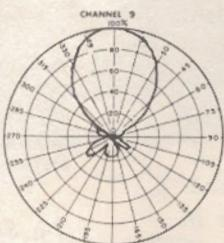
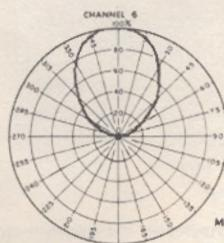
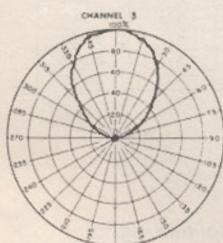

MSA-2719

POLAR RESPONSE PATTERNS

NOTE

Some types of antennas such as illustrated in figure 82 have excellent Front-to-Back ratios but have "suck outs" on certain channels. These "suckout" characteristics must be taken into consideration when choice of this antenna is contemplated.

Fig. 82—"Stacked" high gain antenna.

ANTENNA SYSTEM ACCESSORIES

Attenuator Pads

When color reception is not satisfactory in strong-signal areas, it may be necessary to reduce the level of the input signal. Excessive input voltage develops high AGC voltages which reduce the gain of the RF-IF amplifiers to an extent that many affect the response of the amplifiers. Try several attenuator pads with different values of attenuation ranging up to 10 db (or even more in locations where the signal is very strong.) Connect the pad between the transmission line and the receiver, preferably at the input terminals on the RF tuner in order to minimize direct pickup of signal on leads between the pad and the tuner. The use of a pad is also helpful in cases where the receiver does not terminate the transmission line properly. The resistors in the pads should be of the carbon-composition type, not wire-wound.

For convenience, figure 83 shows schematic diagrams and values of the carbon resistors needed to construct pads that will produce respectively, ten-to-one, (20 db) three-to-one (10 db) and two-to-one (6 db) reduction in signal strength.

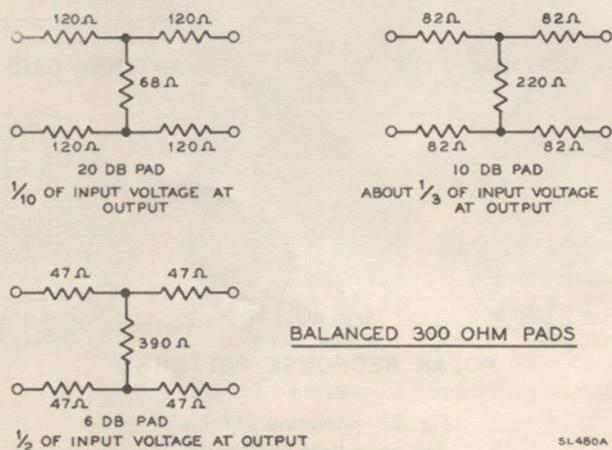

Fig. 83—Attenuator pads for reducing signal input level.

Boosters

In some installations, where it is necessary to increase gain due to an extremely long line run, or lack of sufficient signal at the receiver antenna terminals, a booster is used.

The suitability of any booster, of course, is dependent upon its design. If the booster amplifies only a portion of the 6 mc. channel it probably will not provide adequate signal at or near the color sub-carrier frequency (3.58 mc. above picture carrier frequency).

The installation of a booster having insufficient bandwidth into an adequate antenna system may result in loss of color information.

Signal Distribution Systems

Multiple outlet distribution systems, with or without amplifiers, also require broad-band units (i.e., amplifiers, transformers, tap-offs, etc.) to provide an adequate color signal. Mis-matched impedances between units could result in lack of color signal information at the receiver antenna terminals.

Overloading of amplifiers in an attempt to obtain higher output may cause cross-modulation between the sound and color sub-carrier and create a 920 kc. beat on the screen of the receiver. In installations where this occurs, reduction of the input signal will be required. Additional amplifiers may then be necessary to supply the required number of outlets.

Poor sync, distorted sound, reflections, smear, high-peaking (white outlines), weak picture and loss of color information in the vicinity of the 3.58 mc. sub-carrier frequency can be caused by improper isolation of receivers in a multiple outlet system. Each receiver should have at least 6 db. of resistive isolation from the transmission line.

Many color television receivers will be installed in place of, or in addition to, present black-and-white receivers and may be attached to the existing antenna system. Figure 76 shows a method of isolating two receivers when connected to a common 300 ohm transmission line. In installations where 72 ohm transmission line is used, 39 ohm resistors should be substituted for the 150 ohm resistors shown.

Figure 84 shows a non-amplified distribution system for connecting from two to six receivers to a 300-ohm transmission line.

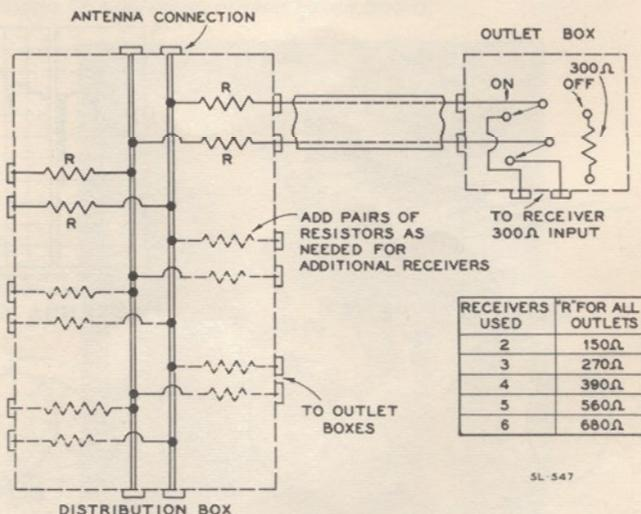

Fig. 84—Schematic diagram—non-amplified signal distribution system.

SUMMARY OF ANTENNA SYSTEM CONSIDERATIONS

Partial or complete loss of chroma due to the antenna system may occur during operation of a compatible color receiver in various ways:

1. Multipath transmission due to reflection from an object or the ground plane.
2. Multipath transmission due to either transmission line pickup or power line signal pickup.
3. Serious antenna impedance mismatch when associated with critical transmission line length and high VSWR of the tuner.
4. Reaction of one receiver on another when both are connected to a common transmission line from the antenna.
5. Highly selective absorption at certain frequencies in some commercial antennas (i.e., "conical" and flat plane "jet-helical" assemblies).
6. Polar patterns of directional receiving antennas improperly oriented or unsuitable antenna polar patterns.

Under these conditions the following installation points will substantially eliminate difficulties due to loss of chroma during color program reception:

1. An antenna rotator should be provided for optimum reception. Alternatively, fixed receiving antennas should be oriented primarily for stations with color transmissions.
2. Antennas with irregularities of more than 2 db in the response curve across a given channel should be avoided.
3. In areas of extreme multipath signal interference it is advisable to resort to a specialized antenna having an extremely high front-to-back ratio, or to an antenna having the proper polar characteristics to solve the problem.
4. Coaxial cables should be employed with elevator or balun impedance transforming units.
5. Where additional TV receivers are installed, the following precautions in decreasing order of merit should be followed: (a) separate antenna installations, or (b) low-capacitance switch in down lead to the several receivers, or (c) resistive isolation pads at junction points of cables and at input to each receiver.
6. High VSWR of the tuner may be reduced by resistive load (300 to 100 ohms) across the tuner input terminals.

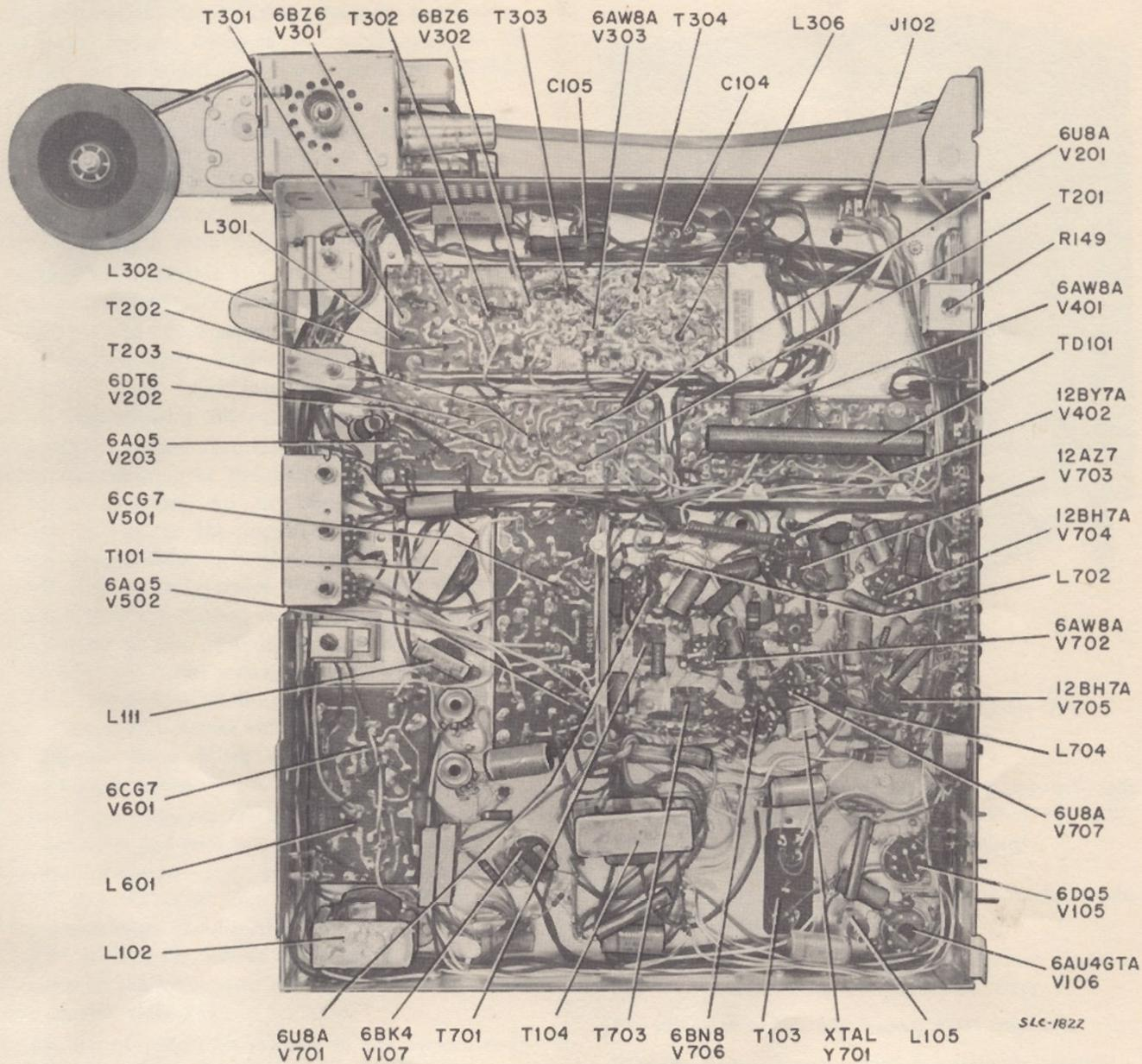
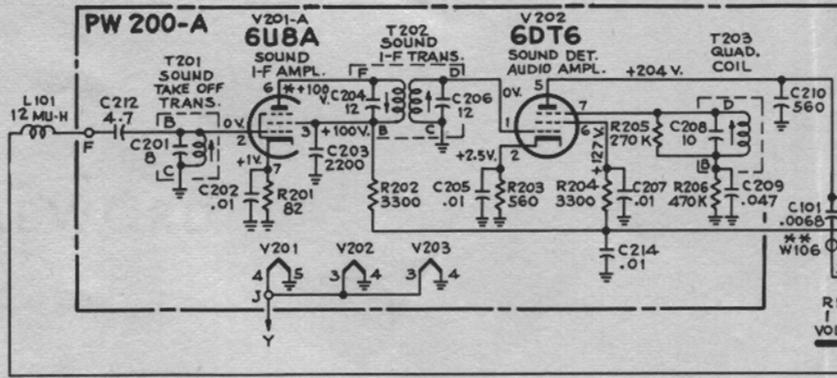
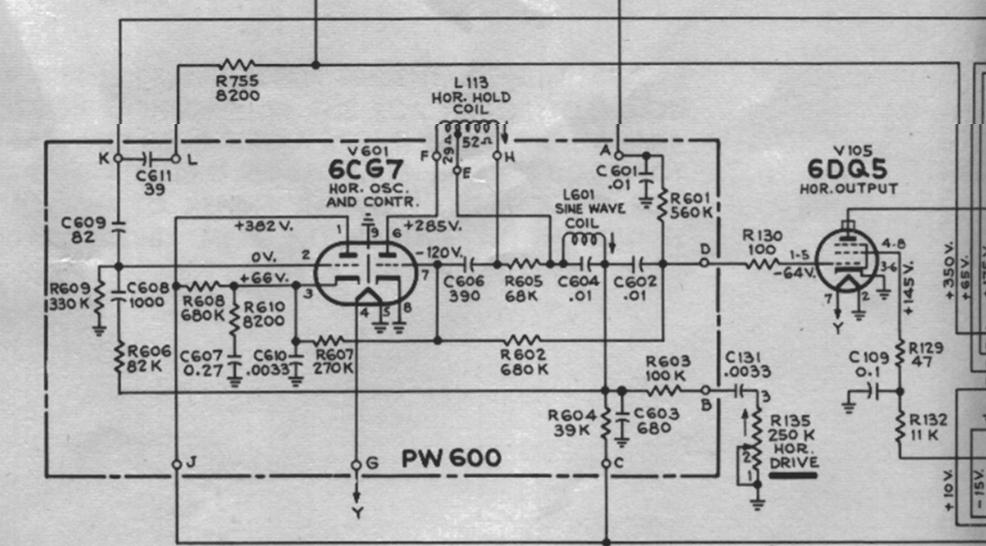
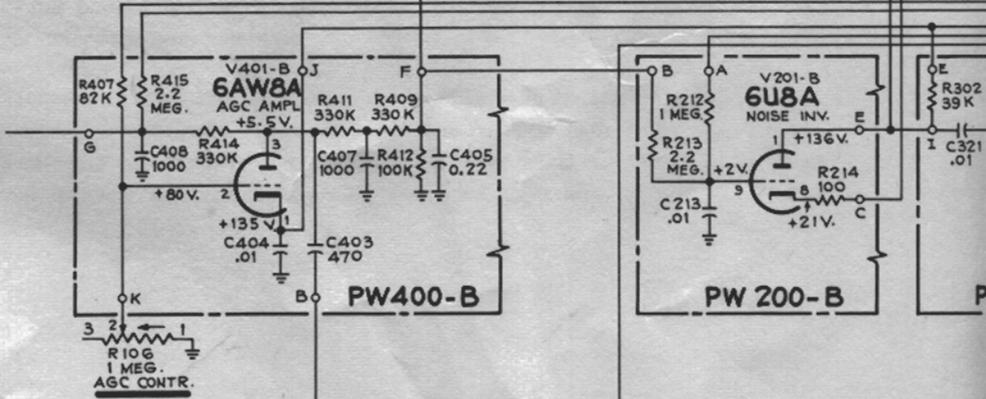
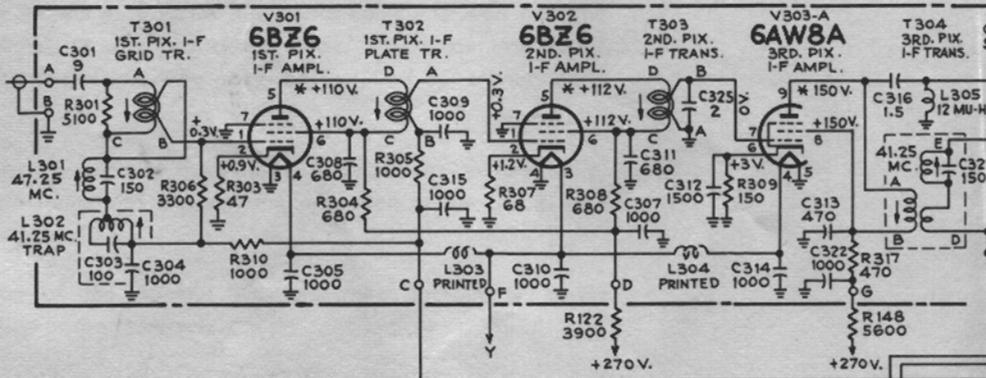
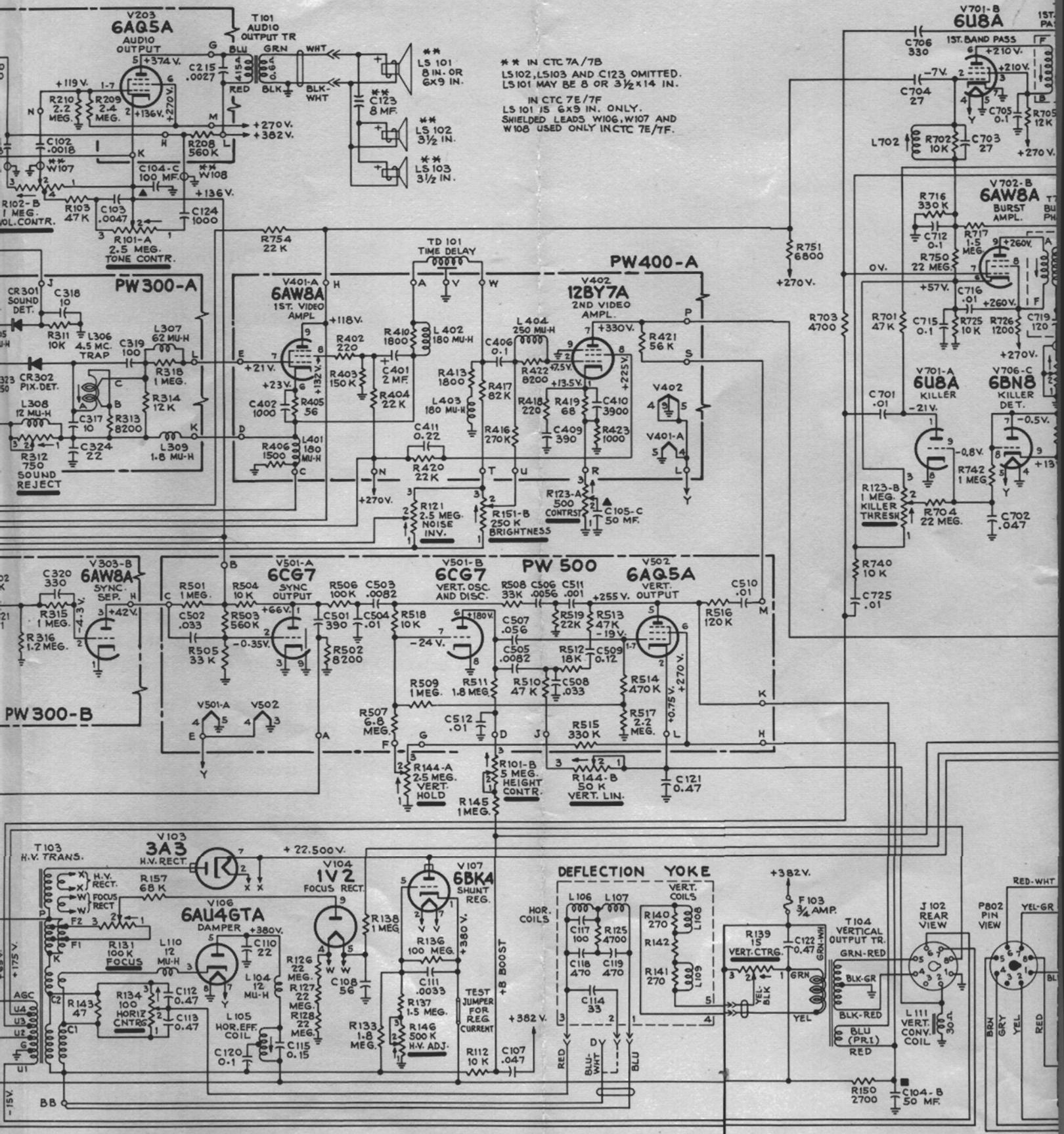

Fig. 86—Bottom view—CTC7 color television chassis showing component and tube locations.



Tuner Schematic Diagrams on Page 8





** IN CTC 7A/7B
LS102, LS103 AND C123 OMITTED.
LS101 MAY BE 8 OR 3 1/2 X 14 IN.

IN CTC 7E/7F
LS101 IS 6 X 9 IN. ONLY.
SHIELDED LEADS W106, W107 AND
W108 USED ONLY IN CTC 7E/7F.

PW400-A

PW300-A

PW300-B

PW500

DEFLECTION YOKE

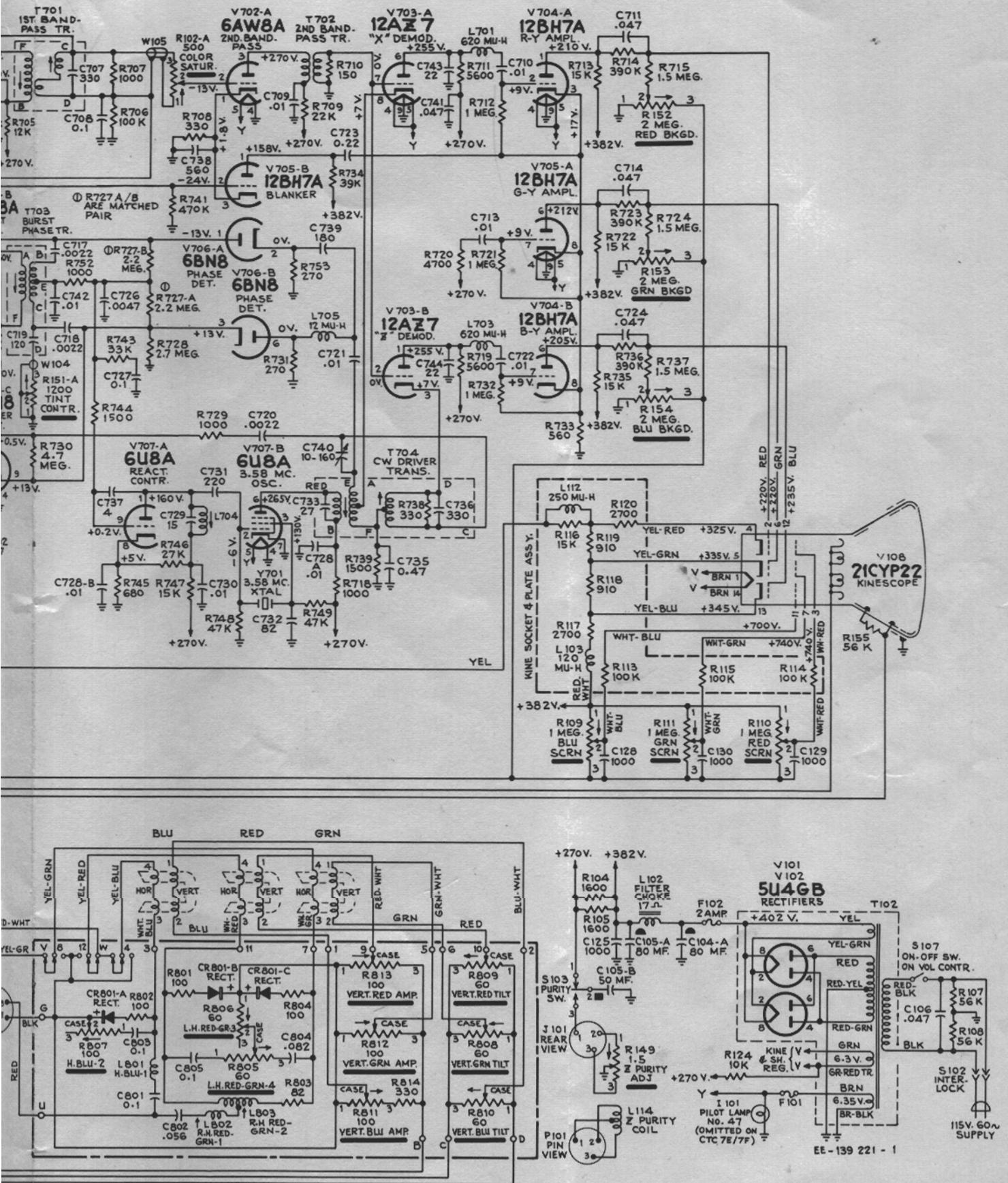

Fig. 87—Schematic diagram—CTC7 color television chassis.